

# EXPERIMENTAL AND ANALYTICAL BEHAVIOR OF REINFORCED CONCRETE BEAMS WITH OPENING USING FOUNDRY SAND

M.V.Nirmala<sup>1</sup>, Pandian Jayalakshmi<sup>2</sup>, Naveen Kumar.B.M<sup>3</sup>

<sup>1,2</sup> Student, Dept. of CIVIL Engineering, SVCE Bengaluru, Karnataka, India.

<sup>3</sup> Assistant Professor, Dept of Civil Engineering, SVCE Bengaluru, Karnataka, India.

\*\*\*

**Abstract** - There are number of ferrous and non ferrous steel casting industries around the world from which hundred million ton of foundry sand has produced in which 40% is used for land filling. Foundry sand is a byproduct of metal casting fields. The research had been carried out in the concrete field by the incorporation of the foundry as a component in the concrete.

This experimental investigation has performed to utilize the foundry sand as fine aggregate in the concrete of M30 grade. This experiment is carried out with different mixes i.e., the replacement of the foundry sand is replaced with 0%-100% in the interval of 10%. Using these mixes the optimization is carried out. The cubes are casted with these mixes and the compressive strength is carried out for 28 days. For the mix with 40% of the replacement of the foundry sand obtained the maximum strength. The beams of the dimension 230mm x 150mm x 2000mm of 6 in number are casted with the optimized percentage of foundry sand. In this experiment the beams are casted with rounded rectangular opening. The beams are tested in the loading frame under two point loading. The test results showed appropriate increase in the strength with the use of the foundry sand as fine aggregates.

**Key Words:** Foundry sand, steel castings, compressive strength, flexural behavior.

## 1. INTRODUCTION

The versatility, sustainability, durability, economy properties of concrete has made concrete the world's most widely used construction material. Due to the several advantages of the concrete over the past few decades the demand for the concrete has been increasing drastically as the growth in infrastructure development is growing rapidly.

Concrete is a composite material composed of cement, aggregates, water and several admixtures. Here the river sand is one of the most important ingredients in the production of concrete which is used as fine aggregate. Due to the massive production of concrete the massive use of river sand has went up. Due to which there is environmental hazards like increasing in the depth of the river bed, lowering of the water table and the intrusion of salinity into the rivers.

There is restriction in the extraction of sand from the river that has lead to the increase in the price of sand and has several terms affected the stability of the construction industry. Keeping all these consequences in consideration an alternative materials are found to be used in the place of river sand.

An industry will have to face some of the circumstances and to overcome the industrial challenges. One of the major challenges with the environment awareness is land filling of the byproducts/wastes. An alternative to dispose the waste is the utilization of the waste. Introducing the concept of using industrial byproducts such as foundry sand, fly ash, ground granulated blast furnace, slag can results in significant improvements in all industries and improvement in environmental performances.

In the construction of the multi facility, modern buildings the network of pipes, ducts are necessary to accommodate the essential facilities, services like sewage, water supply, air conditioning, electricity, computer networks, telephone. Generally all these connections will be beneath beam soffit for the aesthetic reason, but in critical conditions the provision of transverse opening in floor beams to facilitate the passage of utility pipes and ducts, hence to investigate the behavior of beams with openings and with the partial replacement of foundry sand for fine aggregates, this experiment is carried out.

Foundry sand is high quality sand with uniform physical characteristics. It is a byproduct of ferrous and non ferrous metal casting industries. Foundries can be recycled and reused. When the sand can no longer be reused it is called as foundry sand. Using the foundry sand as fine aggregates instead of land filling. The volume of waste sand going to landfill can be reduced.

The raw sand is normally of a higher quality than that of the natural sand or typical bank run used in fill construction sites. The sands form the outer shape of the mold cavity. These sands normally rely upon a small amount of bentonite clay to act as the binder material. Chemical binders are also used to create sand "cores". Depending upon the geometry of the casting, sands cores are inserted into the mould cavity to form internal passages for the molten metal. Once the metal has solidified, the casting is separated from the molding and core sands in the shakeout process. In the casting process,

molding sands are recycled and reused multiple times. Eventually, the recycled sand degrades to the point that it can no longer be reused in the casing process. At that point, the old sand is displaced from the cycle as byproduct, new sand is introduced, and the old sand is displaced from the cycle as byproduct, new sand is introduced, and the cycle begins again.

**2. OBJECTIVE**

The main objective of this experimental work is the utilization of the waste foundry sand as fine aggregate

1. To study the behavior of concrete in flexure with the foundry sand as the fine aggregates for M<sub>30</sub> grade concrete.
2. To study the behavior of the beams with rounded rectangular opening with fine aggregates as foundry sand.
3. To study the compressive strength, flexural strength of concrete for 7 and 28 days with partial replacement of foundry sand.
4. To investigate the strength of the replaced concrete with that of the conventional concrete.
5. To study the beam with opening by replacement of fine aggregate compared with that of the conventional beam with opening.

**3. METHODOLOGY**

**Material and Testing**

The materials used for the concrete are selected from the concrete industry. The materials used in the concrete are fine aggregates, coarse aggregates, cement, water, mineral admixture (foundry sand), chemical admixtures (super plasticizer - BASF 8333).

**A). FOUNDRY SAND**

The sample foundry sand is collected from Emerald steel works, Bengaluru. The foundry sand is categorized as a fine aggregate in concrete study and also the manufactured sand is used in the concrete to study its behavior.

Taking the cement content 340kg/m<sup>3</sup>, these materials are used with the foundry sand in different percentages as 10%, 20%, 30%, 40%, 50%, 60%, 70%, 80%, 90%, 100%. The mix proportion is obtained from the characterization of all the materials.

As the preliminary stage certain tests are conducted on the materials used in concrete as per the guidelines of Indian Standard (IS). The tests on materials were conducted as follows, specific gravity of cement, fine aggregates, coarse aggregates, and the water absorption test for fine and coarse aggregate. The normal consistency of cement, initial and final setting time of cement. The test on concrete were conducted as follows, compressive strength.

**Table -1:** Physical properties of foundry sand

Sl No	Property	Results	Sl No
1.	Specific Gravity	2.45	1.
2.	Water absorption, %	0.46	2.
3.	Bulk density, Kg/m <sup>3</sup>	2582	3.
4.	Fineness modulus %	3.9	4.



**Fig -1:** Foundry sand

**B). MANUFACTURED SAND**

The quality of the manufactured sand is examined with certain parameters such as specific gravity, water absorption, bulk density under the guidelines of IS : 2386. The results are noted with respect to the codal provision of IS: 383-1970.

**Table -1:** Properties of manufactured sand

Sl No	EXPERIMENTS CONDUCTED	RESULTS
1.	Specific gravity	2.6
2.	Water absorption, %	4
3.	Rodded bulk density, Kg/m <sup>3</sup>	1785
4.	Loose bulk density, Kg/m <sup>3</sup>	1610
5.	Finesse modulus	3.79

**C). CEMENT**

For this experimental study the Ordinary Portland Cement (OPC) of grade 53 confirming to IS:12269-1987 is used. The preliminary tests were conducted to determine the physical properties of the cement as per IS:269 and IS:4831 satisfying the requirements as per IS : 12269-1987.

**Table -2:** Properties of Cement

SI No	DESCRIPTION	RESULTS ATTAINED	NECESSITIES AS PER IS:12269-2013
1.	Standard uniformity(%)	29%	-
2.	Initial setting time	210 min	30 min
3.	Final setting time	315 min	600 min
4.	Fineness, Kg/m <sup>2</sup>	280	Min 225

**4. MIX DESIGN**

Under the guidelines of IS: 10262-2009 considering the cement content of 340 Kg/m<sup>3</sup>. Based on this the different properties are considered for the mix proportioning. The presented mix design is for M30 grade utilizing the fine aggregates as foundry sand with the different percentages.

**Table -3:** Design mix for FA manufactured sand, Cement content 340 Kg/m<sup>3</sup>

MATERIALS	BATCH MIX 'Kg/m <sup>3</sup> '	AFTER WATER CORRECTION	SPECIFIC GRAVITY	Batch quantity for 0.035m <sup>3</sup>
Cement	340	340	3.15	11.9 kg
FA foundry sand	382	380.28	2.6	13.4 kg
Manufactured sand	573	570.42	2.66	20.1 kg
CA - 20mm	751.2	748.2	2.57	26.3 kg
Water	166	-	1.0	17.53 kg
Admixture	2 %	-	1.08	0.3 lt

**Table -4:** Design mix for FA manufactured sand, Cement content 340 Kg/m<sup>3</sup>

MATERIALS	BATCH MIX 'Kg/m <sup>3</sup> '	AFTER WATER CORRECTION	SPECIFIC GRAVITY	BATCH QUANTITY
Cement	340	340	3.15	11.9 kg
FA	955	950.7	2.66	33.4 kg
CA - 20mm	751.2	748.2	2.57	26.3 kg
CA- 12.5mm	500.8	498.8	2.57	17.53 kg

Water	166	-	1.0	5.82 lt
Admixture	2 %	-	1.08	0.3 lt

**5. EXPERIMENTAL METHODOLOGY**

The optimization of the foundry sand is developed by the compressive strength. With the control concrete i.e., 0% - 100% in the interval of 10% of the fine aggregates is replaced with foundry sand. Twenty cubes of size 150\*150\*150 mm were casted and after 24 hours the specimens were de-moulded and water curing was continued till the respective specimen were tested after 7 and 28 days of compressive strength.

**Table -5:** Compressive strength

SI No	% OF Foundry Sand	Compressive Strength of Specimen at the age of 7 days	Compressive Strength of Specimen at the age of 28 days
1.	10	25.4	31.05
2.	20	25.38	32.52
3.	30	25.73	33.03
4.	40	26.93	35.72
5.	50	26.02	35.49
6.	60	25.8	35.08
7.	70	24.86	34.81
8.	80	24.51	34.64
9.	90	24.2	33.75
10.	100	24.08	33.28

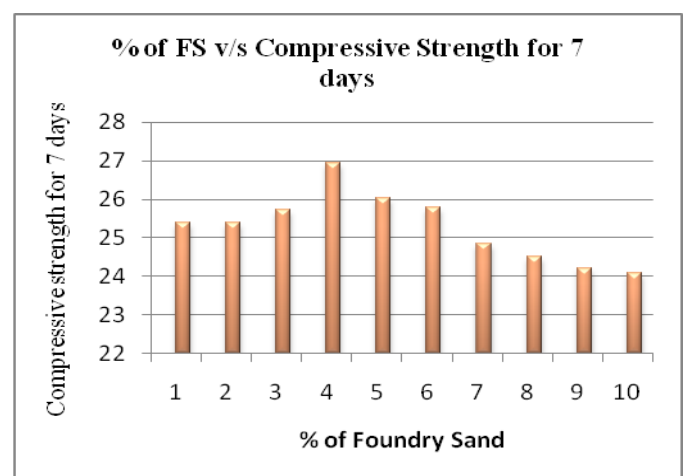

**Chart 1-** Compressive strength v/s % of foundry sand (7 days)

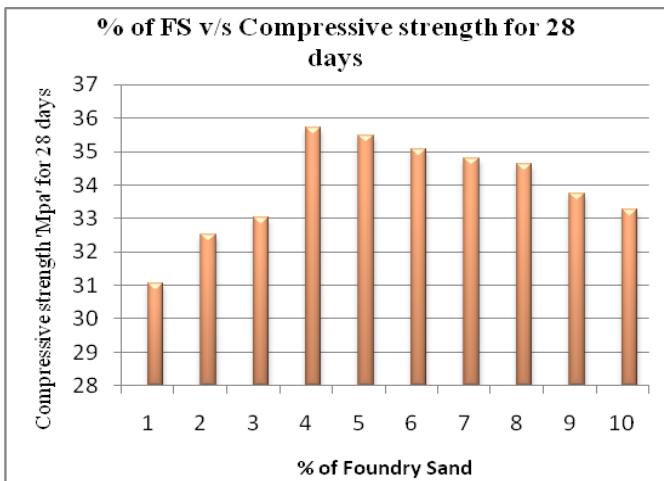

Chart 2- Compressive strength v/s % of foundry sand (28 days)



Fig 3 – Casting of beam

### 6. REINFORCEMENT DETAILS

The HYSD bars of 16mm and nominal steel of 10mm dia bars are provided. The main bars in the tension zone and the nominal steel in the compression zone is provided. The special reinforcement is provided around the opening. The bars verified to IS : 1786 ,Fe 500 grade bars have been used.

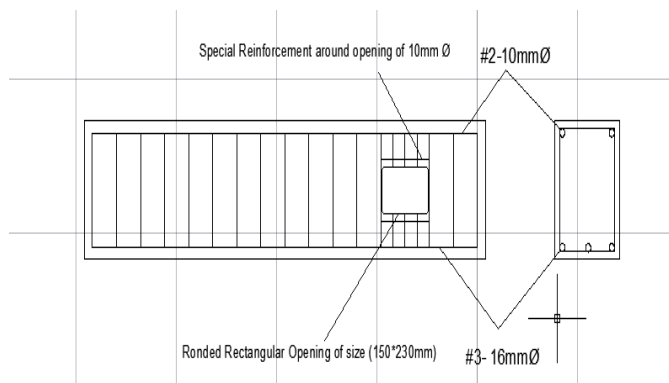

Fig 2 - Reinforcement details.

### 7. CASTING OF BEAMS

Initially the inner surface of the formwork has to be applied with the oil. The reinforcement cage should be placed inside the mould using the cover blocks of 20mm. The well mixed concrete is poured into the mould in three layers and each layer is properly tamped and smooth surface finish is given. These beams are kept for 24 hours and de-moulded. The curing has to be carried out for 28 days.

### 8. EXPERIMENTAL SETUP

The beams are tested under loading frame of capacity 100-tonnes with the oil pressure of 200Kg/cm<sup>2</sup>. The beams are tested under loading frame by two point loading in order to obtain the pure bending. To obtain the strain in the beam the strain gauges are fixed to the beams. The strain gauge is then connected to the control panel. The Linear Variable Differential Transformer (LVDT). The Linear Variable Differential Transformer is used to determine the deflection in the beam at the failure load. The LVDT is then connected to the control panel that gives the deflection graph. The setting is as shown in the fig below.

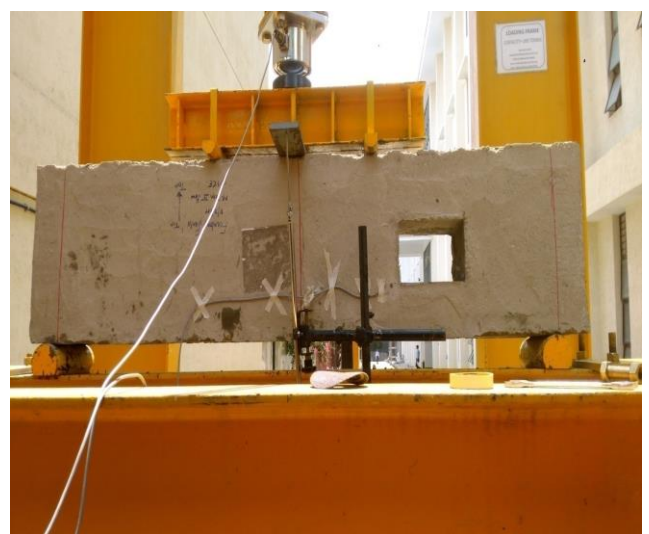

Fig 4 - Test setup for testing beam





Fig 5 - The failure of beam after the test

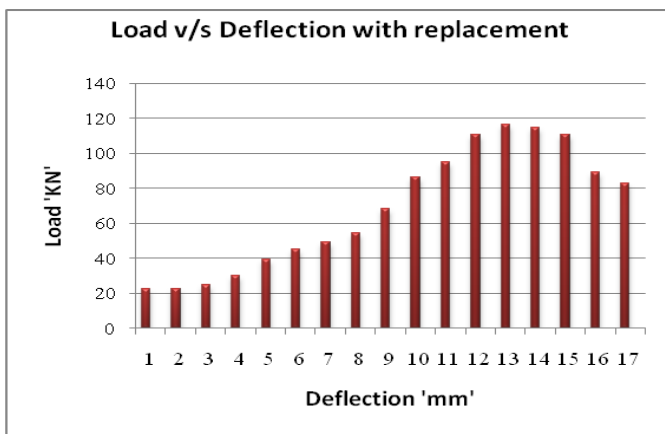

Chart 3- Load v/s Deflection with replacement

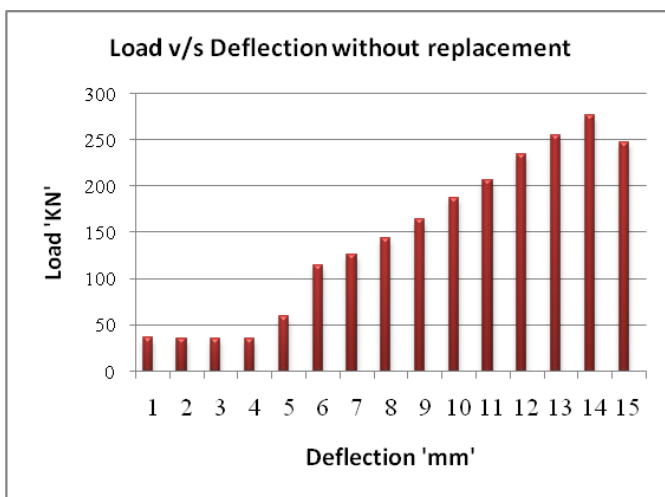

Chart 4- Load v/s Deflection with replacement

1. The optimized value of foundry sand obtained as 40% for 28 days of compressive strength. The compressive strength obtained was in and around to the conventional concrete.
2. The compressive strength gradually increased with the addition of the foundry sand.
3. From the compressive strength results, the replacement of foundry sand material gives highest strength for 40%.
4. The use of the foundry sand used in concrete in other word is known as green sand obtained from steel industries reduces the landfilling and hazardous effects on nature.

REFERENCES

- [1] "Replacement of fine aggregates with in concrete" by Deepak Chaurasiya, Kiran Koli, Suraj Chaudhari – International Journal on Theoretical and Applied Research in mechanical Engineering. Volume 5, Issue 1, February 2016.
- [2] "Flexural behavior of RC beams using as partial replacement of fine aggregates" by Umashankar A, Shashikumar A. International Journal of Research in Engineering and Technology. Volume 5, Issue 8, August 2016.
- [3] "Effects of as a fine aggregate in concrete production" entitled by G.Ganesh Prabhu, Jung Hwan Hyun, Yun Yong Kim - Science Direct, September 2014.
- [4] "Effect of on the mechanical properties of concrete" by Rafat Siddique, Geert de Schutter – Science Direct.
- [5] Gurpreet Singh, Rafat Siddique as "Effect of waste as partial replacement of sand on the strength,ultrasonic pulse velocity and permeability of concrete" – Science Direct.
- [6] "Waste foundry sand as a replacement for fine aggregate in high strength solid masonry blocks", by Mahima Ganeshan, Dr.Sreevidya V. International Journal of Innovative Research in Science ,Engineering Technology.
- [7] "Flexure behavior of reinforced concrete beams with opening" by Saeed Ahmed Sheikh, Concrete Research, Volume 5(2), June 2014.
- [8] "Flexure behavior of reinforced concrete beams with opening" by Saeed Ahmed Sheikh, Concrete Research, Volume 5(2), June 2014.

9. CONCLUSION

From the experimental results obtained from this work on the beams of M30 grade the subsequent conclusion were established.

**BIOGRAPHIES**

M.V.Nirmala : Pursuing her M-Tech studies at department of Structural Engineering, SVCE, Bengaluru. Her research area includes experimental and analytical behavior of reinforced concrete beams with opening using foundry sand.



Pandian Jayalakshmi : Pursuing her M-Tech studies at department of Structural Engineering, SVCE, Bengaluru.

Naveen Kumar.B.M. : Assistant Professor at department of civil engineering,SVCE,Bengaluru