

# Design of Low-Voltage Distributed Photovoltaic Systems oriented to improve fault ride through capability

R. V. GOWTHAM<sup>1</sup>, Dr. P. SUJATHA<sup>2</sup>

<sup>1</sup>PG Student Dept. of EEE Engineering College, Anantapur, Andhra Pradesh, India

<sup>2</sup>Professor Dept. of EEE Engineering College, Anantapur, Andhra Pradesh, India

\*\*\*

**Abstract** - Photovoltaic (PV) systems have gained prominence as economically-viable, long-term alternatives to conventional, non-renewable sources of energy. The optimum design characteristics that Distributed Generation photovoltaic units incorporated in order to meet the requirements of Low-Voltage Ride Through Capability (LVRTC) are evaluated in this paper. Without the optimal design of DG-PV units that are connected to low voltage distribution networks, certain limitations regarding performance rises in the network transient phenomenon condition. The analysis evaluates that, with appropriate selection of equivalent interconnecting reactance  $X_{DG}$  in the oversized interfaced inverters of DG-PV in merging with high penetration levels yields satisfaction of LVRTC demands without violating the protection limits of the network. Furthermore, along the distribution lines, uniform dispersion is can be observed concerning the demand of LVRTC for voltage selectivity. Finally, considering the derived outcomes, optimum design of DG-PV about LVRTC within the framework of reasonable constraints, can be applied to any low-voltage distribution network. In order to check the performance of the entire network system, addition of a new LV network to the existing network is done. The results are evaluated and compared in MATLAB simulation software.

**Key Words:** Distributed Generation photovoltaic units, low voltage ride through capability, Photovoltaic system.

## 1. INTRODUCTION

Due to limited capacity of fossil fuels, the world is focussing on the usage of renewable power generation in terms of electricity production and fulfilling its growing demand. Hence, it will not be a wrong to say that renewable power generation will be a significant source of energy in the near future. Furthermore, among many notable green energy sources, the world is mainly focussing on the usage of SOLAR energy to meet their demand. Photovoltaic is the process of converting sunlight directly into electricity using solar cells. With increasing consumption of electric energy in the context of limited conventional energy sources such as coal, natural gas and crude oil it is necessary to seek and use other energy sources. Hence the utilization of non-conventional energy is increasing in day to day life. Mainly the world is focussing on solar energy and wind energy. The majority of the power can be evaluated using solar energy compared with wind energy due to certain parameters. Due to some of

considerable advantages like flexible installation, minimum upkeep etc., Solar energy or Photovoltaic (PV) energy power plants are nowadays exhibiting globally a notable development. The grid connected Distributed Generation Photo Voltaic (DG-PV) is the most essential assurance of PV systems because of some parameters like proven very efficiency and cost consideration. In spite of that, DG-PV penetration level (PL) is usually restricted (by distribution companies) to the level of less than 20% of the substation installed power due to some constraints. In this way, PV production impact on the distribution grid operation, especially in the event of electrical power system unbalance, is significantly reduced. However, due to such strict constraints, the progress of the further development and incorporation of renewable energy sources (RESs) into the electrical power systems is limited to certain extent. To get over this, all RES generators (wind parks, PV systems and so on) have to acquire operating features akin to that of conventional power plants (based on synchronous generators), in order to contribute to a fault event too. Therefore the standard of Low-Voltage Ride Through Capability (LVRTC) has been adopted in all types of RES attached to high- and medium-voltage grid. In particular, the high power level of wind farms favoured the integration of LVRTC concept in this type of RES and much improvement has already been achieved.

With the growth in PV plants, especially that are connected to transmission network, many countries in global research markets started to implement the LVRTC scheme in PV units [1]. Regarding the LVRTC scheme, the global energy markets vary. The Fig. 1 below describes that with the implementation of LVRTC scheme in many countries such as Germany, Taiwan, North America, Australia, Denmark etc., the desired behaviour of the interconnected units in case of a voltage drop at their point of common coupling (PCC) is observed [2]. Particularly the Fig. 1 evaluates that the time interval that a DG unit has to stay connected to the grid depends on the voltage dip level, mainly as the voltage becomes lower, this time interval decreases.

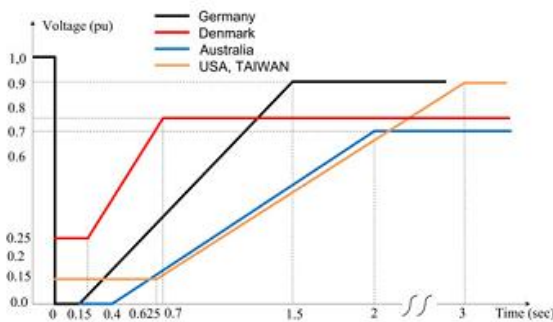

**Fig-1:** LVRTC schemes of several energy markets

With the aspects stated above, the standard of LVRTC is extended so as to include the DG-PV units that are connected to the low-voltage network is evaluated with the addition of a single BUS bar to the existing network. The necessary inverter over-sizing is thoroughly monitored in order to meet LVRTC requirements. Hence, the interfaced inverters are obliged to be coupled with the low-voltage network and feed the faulty part for time intervals that last more than a few line cycles. Therefore they have to be dimensioned for a significantly longer duration of faulty conditions, calling for more effective thermal management and much higher over current and overvoltage strength, combinable termed as the over-dimensioning (OD) of PV inverters [3]. The analysis of LVRTC application on LVDG-PV systems focuses especially on the Penetration Level (PL). Studies about the PL limits of PV units have been recently presented [4]. The inverter design is taken into account and the evaluation of PL parameter is extended in terms of meeting the current LVRTC requirements satisfactorily. And also, in order to fulfill the new operational demands and improving distribution network during disturbances, the necessary adjustments on the PV units must be incorporated.

In Section 2, through a detailed theoretical analysis LVDG-PV design guidelines are presented. In Section 3, the optimum design of existing network is added with one low voltage distribution network to check the optimum design is applicable to any distribution network at higher PL values.

## 2 LVDG-PV design guidelines according to LVRTC

The main generalised theme of LVRTC scheme with reference to the fig.1 is to restrict the unnecessary simultaneous breakdown of multiple generation sources in the network disturbance condition the generation sources should be operating (or) connected to low-voltage distribution network for some duration of time from the fault network and operation time is based w.r.t electrical degrees function. Here the definition of the term voltage selectivity rises because electrical distance in above condition is expressed by voltage dip at Distributed Generator's Point of Common Coupling (PCC).

One of the important characteristic for the high expansion of DG-PVs in focus of high penetration level is generation loss is limited to the near ones that are close to the faulty network part in case of short duration faults.

The distributed network have a radial structure i.e., if case of fault condition occurred in a network path, there is no alternative distribution path. More over the units that are closest to the fault networks are effected more. Therefore according to the LVRTC scheme since there is no alternative path the DG's should fed the faulty part. Based on the above aspects the design of interfaced inverter should be such that the proper voltage selectivity is achieved so that on feeding faulty part during the fault interval time, the interfaced inverters should withstand the higher currents than nominal currents in order to stay connected with the distributed network (or) in continuous operation condition. This ideas of aspect evaluated several commercial inverters that are supporting the above characteristics during over current short term disturbances and so on LVRTC.

The performance and features of the DG units during a disturbance should be nearly as the performance of synchronous Generator. This can be done by adjusting the operational characteristics of the synchronous Generator to the terms of LVRTC so that in case of disturbance the DG units must withstand higher currents than nominal rated currents, since they shall be disconnected after atleast 0.15sec (referred to fig. 1) reaching steady faulty conditions. Therefore from the above aspects, it is preferable for the LVDG-units should behave as voltage sources instead of constant source in disturbance condition so that they provide higher than the nominal values of current. The deviation between transient and steady-state currents can be controlled with the LVDG-PV units in the networks [5].

There are certain aspects that should be incorporated in design concept. They are :

1. All LVDG-PV units must behave as a voltage source in series with a reactance in faulty conditions.
2. The algorithms related to interfaced inverters to achieve above aspects must redefined. This is because there should be a suitable response in case of a high PL value so as to meet the desired voltage selectivity value. In particular, in order to avoid unnecessary generation divergences the inverter signal must retain its pre-disturbance value in case of short-term disturbances. In long-term disturbances, the inverter controller is triggered either to reduce current within safe- limits (or) trip LVDG-PV units, if the time limit is exceeded.

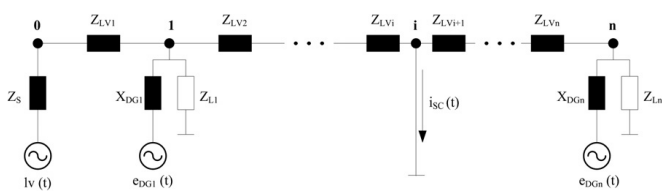
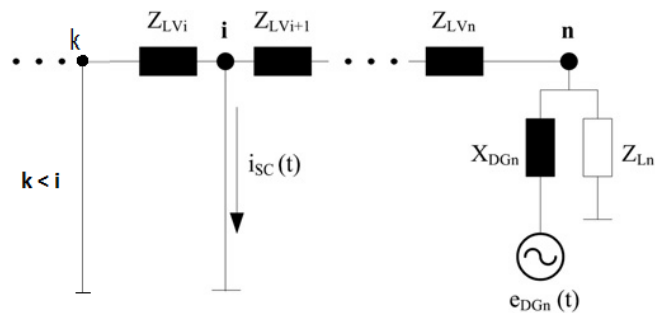

**Fig-2:** Single-phase equivalent circuit of LV distribution network line with DG-PV units

limits (or) trip LVDG-PV units, if the time limit is exceeded.

3. A Design guide line is presented on the basis of low voltage network form. Only one distribution line is considered for analysis. All connected LVDG-PV units are considered to act as conventional AC voltage sources based on the above analysis in fault condition. A three-phase low-voltage network with DG-PVs, operating under unity power factor in steady state is considered. If a three-phase short circuit occurs at the i-bus, then the single-phase equivalent circuit of Fig. 2 stands.

A similar modeling of distribution network equipped with DG units for disturbance studies has already been presented in [6]. The three-phase short circuit is used for dimensioning the network's protection equipment, so the worst case is included. The calculation of bus voltages after a fault is carried out through the superposition process, which is absolutely equivalent to the classic method ( $Y_{bus}$ ) [7]. However, it offers a better sense of the radial distribution network passive elements, which affect the bus voltages after a three-phase short circuit. Considering a three-phase short circuit at the i-bus in Fig. 2, the voltage at k-bus is derived from the sum of contributions from all sources. Particularly, for  $k < i$  (fig 2.1) it can be calculated as



**Fig-2.1:** Single-phase equivalent circuit of LV distribution network line with fault at the bus i

$$V_{k,SCi} |_{k < i} = V_{k \rightarrow k,SCi} + V_{IV \rightarrow k,SCi} + \sum_{j=1}^{k-1} V_{j \rightarrow k,SCi} + \sum_{j=k+1}^i V_{j \rightarrow k,SCi} \quad (1)$$

Similarly, for the buses that are on the right side of the short-circuited bus ( $k > i$ ), the following expression stands

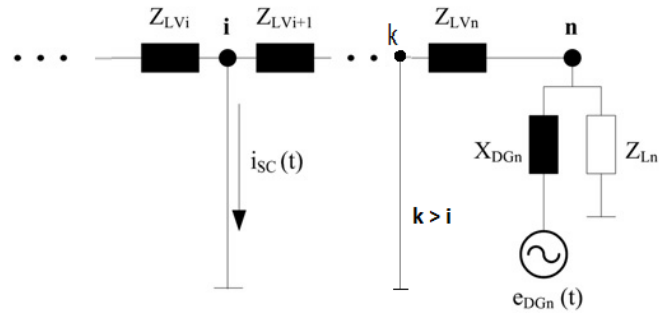

**Fig-2.2:** Single-phase equivalent circuit of LV distribution network line with fault at the bus i

$$V_{k,SCi} |_{k > i} = V_{k \rightarrow k,SCi} + V_{IV \rightarrow k,SCi} + \sum_{j=i+1}^{k-1} V_{j \rightarrow k,SCi} + \sum_{j=k+1}^n V_{j \rightarrow k,SCi} \quad (2)$$

The calculation of the individual terms in (1) and (2) arises from the superposition principle of sources.

Equation set for the analytical calculation of bus voltages after the short circuit are as follows

For  $k < i$

$$V_{k \rightarrow k,SCi} |_{k < i} = E_{DGk} \frac{1}{1 + (jX_{DGk} / Z_{k,SCi})} \quad (3)$$

$$V_{IV \rightarrow k,SCi} |_{k < i} = LV \frac{1}{1 + \frac{Z_s}{Z_{0,SCi}}} \prod_{j=0}^{k-1} \frac{Z_{j,R,SCi} - Z_{LVj+1}}{Z_{j,R,SCi}} \quad (4)$$

$$V_{j \rightarrow k,SCi} |_{j < k < i} = E_{DGj} \frac{1}{1 + (jX_{DGj} / Z_{j,SCi})} \prod_{p=1}^{k-1} \frac{Z_{p,R,SCi} - Z_{LVp+1}}{Z_{p,R,SCi}} \quad (5)$$

$$V_{j \rightarrow k,SCi} |_{k < j < i} = E_{DGj} \frac{1}{1 + (jX_{DGj} / Z_{j,SCi})} \prod_{p=k+1}^j \frac{Z_{p,L,SCi} - Z_{LVp}}{Z_{p,R,SCi}} \quad (6)$$

For  $k > i$

$$V_{k \rightarrow k,SCi} |_{k > i} = E_{DGk} \frac{1}{1 + (jX_{DGk} / Z_{k,SCi})} \quad (7)$$

$$V_{IV \rightarrow k,SCi} |_{k > i} = 0 \quad (8)$$

$$V_{j \rightarrow k,SCi} |_{i < j < k} = E_{DGj} \frac{1}{1 + (jX_{DGj} / Z_{j,SCi})} \prod_{p=1}^{k-1} \frac{Z_{p,R,SCi} - Z_{LVp+1}}{Z_{p,R,SCi}} \quad (9)$$

$$V_{j \rightarrow k,SCi} |_{i < k < j} = E_{DGj} \frac{1}{1 + (jX_{DGj} / Z_{j,SCi})} \prod_{p=k+1}^j \frac{Z_{p,L,SCi} - Z_{LVp}}{Z_{p,R,SCi}} \quad (10)$$

$$Z_{k,SCi} = Z_{k,L,SCi} // Z_{k,R,SCi} // Z_{LK} \quad (11)$$

It is worth mentioning that if there is no generation or load at  $k$ -bus, the above equations stand if  $E_{DGk}$  becomes infinite, for the specific  $k$ -bus. Considering that DG-PVs supply only active power in steady state, the internal voltage of a DG connected to the  $k$ -bus is modelled as follows

$$P_{DGk} = \frac{|E_{DGk}| * V_k * \sin \delta_k}{X_{DGk}} \quad (12)$$

Furthermore as the DGs operate under unity power factor, the following equations stand

$$P_{DGk} = V_k * I_{DGk} \quad (13)$$

$$\tan \delta_k = \frac{X_{DGk} * I_{DGk}}{V_k} \quad (14)$$

Combining (14) and (15) the following expressions can be given

$$\tan \delta_k = \frac{X_{DGk} * P_{DGk}}{V_k^2} \quad (15)$$

Finally, from (12) to (15) the  $E_{DGk}$  can be extracted as

$$E_{DGk} = \frac{P_{DGk} * X_{DGk}}{V_k * \sin(\tan^{-1}(\frac{X_{DGk} * P_{DGk}}{V_k^2})) \angle \tan^{-1}(\frac{X_{DGk} * P_{DGk}}{V_k^2})} \quad (16)$$

From equation 16 it is clear that the internal voltage of DG units depends on bus voltage and DG active power which steady state parameter at their PCC. From the load flow analysis the pre fault bus voltages and the LV voltages are extracted. It is obvious that these voltages changes if  $P_{DG}$  varies, above equations apply only at typical distribution networks with radial structure

Equations (1)-(16) taking into account, the DG contribution to a fault current in case of DG connected to the  $k$ -bus is given by

$$I_{DGk,SCi} = \frac{E_{DGk} - V_{k,SCi}}{jX_{DGk}} \quad (17)$$

Example on how the above equation set can be used for the determination of the minimum bus voltage. If the short circuit takes place at its neighbouring bus minimum voltage condition occurs at  $n$ -bus. Short circuit at  $n-1$  bus is the worst case because it leads  $n$ -bus to its smallest possible voltage level(excluding the case of short circuit at  $n$ -bus itself). The root mean square(rms) voltage at the terminal bus as follows

$$V_{n,SCn-1} = V_{n \rightarrow n,SCn-1} = E_{DGn} \frac{1}{1 + (jX_{DGn} / Z_{LVn})} \quad (18)$$

Considering that the internal rms-voltage of LVDG-PV unit is roughly 1pu (in order to generate power under unity or slightly leading power factor), we come up with the marginal minimum rms-voltage at a 'healthy' bus

$$V_{min,rms}(pu) = \frac{1}{d_{min}}, \quad d_{min} = |1 + \frac{jX_{DGn}}{Z_{LVn}}| \quad (19)$$

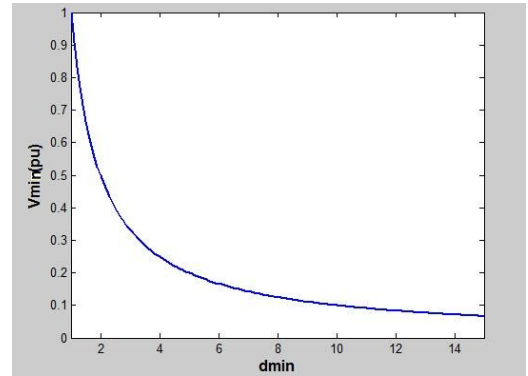

Fig-3: Example of the proposed LVDG-PV design concept for high PL values

Fig.3 depicts  $V_{min,rms}$  as a function of  $d_{min}$  in the context of a design example, considering a specific LVRTC scheme (also presented in the same figure). Minimum voltage level can be achieved by setting  $d_{min}$  value in case of a three-phase sort circuit at neighbouring bus. Specifically from fig.3 the selection of  $d_{min}$  below 6.5 reassures that voltage at 'healthy' buses shall always be  $> 0.15pu$  and so they have to stay connected for atleast 0.625ms(more than 30 lines cycles in 50Hz systems). In this way, the philosophy of LVRTC is served and so impermanent faulty conditions would have limited impact on the available DG-PV power production.

### 3 Integration of new LV network to the existing Distribution network

The optimum design of LVDG-PV systems which is proposed in existing network(11) mainly depends on the selection of  $X_{DG}$  and PL values in the direction of high possible values of buses voltages under faulty condition. The above aspect mainly opposes the impact of the temporary potential disturbance on the DG-PV power production. Mainly the optimization process is came out for a network with equal DG-PV units and it can be easily applied at any distribution network with increased DG-PV penetration.

In order to prove this optimum design is applicable to any distribution network here we are adding existing network with one additional LV network is shown in fig4 to check overall performances of the system at higher penetration level.

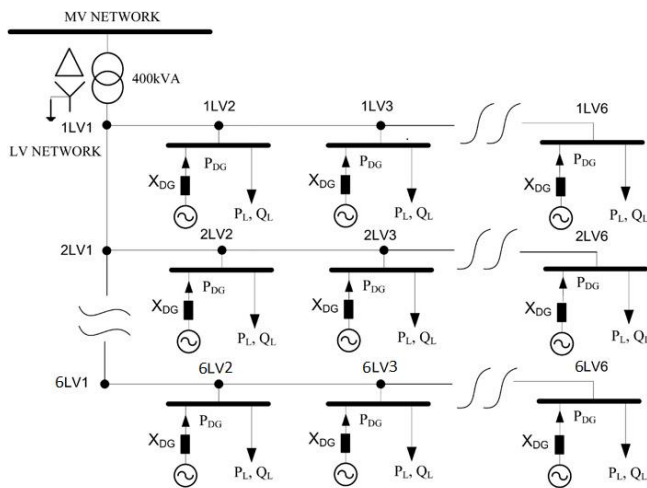

**Fig-4:** Layout of distribution network with DG-PV units with sixth bus

The first step in optimization problems is the definition of an objective function with one or more variables. Through the maximisation or minimisation (depending on the case) of the objective function, the optimum values for these variables are extracted. The parameters of the optimisation function are the  $X_{DG}$  reactance and the PL value. In this paper, the definition of PL is based on the total load demand and is given by the following equation

$$PL(\%) = \frac{\sum P_{DG}}{\sum P_{LOAD}} \times 100\% \quad (20)$$

By making the commercial inverters' supply of over current up to 2.8 times the  $I_{DG}$  for several milliseconds, when disturbances are occurring, the factor  $OD_k$  at k-bus for quality improvement on autonomous LV-PV systems [8] can be defined as depicted below:

$$OD_k(\%) = \left( \frac{d_k \cdot I_{DGk}}{I_{DGk-tr}} - 1 \right) \times 100\% \quad (21)$$

In the optimization process for power quality improvement or autonomous LV-PV equipment's a necessary ( $OD_k$ ) over-dimensioning percentage of  $DG_k$  converters in order to meet the LVRTC demands.

Here the existing distribution network is connected with one extra LV network to check overall performance of the system at high penetration levels.

The objective function for the new network and its constraints are as follows

Objective function

$$f(X_{DG}, PL) = \left[ \sum_{i=1}^6 \sum_{j=1}^6 \sum_{k=1}^6 V_{jLVk,SC\_1LVi} \right] (X_{DG}, PL)$$

Constraints  $OD_k < OD_{limit}$  at k-bus

The main purpose of objective function is its maximization, it means in order to satisfy the LVRTC

demands respecting the DG-PV units OD constraints  $OD_{limits}$   $I_{SC}$  the bus voltages are to be maximize. The optimization process has been conducted for different  $OD_{limits}$  values. The actual PV inverter design and control are noted according to the current standards [2], the fault currents more than 120% of the nominal value does not allowed. According to the EN50160 standards the bus voltages are under steady-state conditions when PL values varies between 20 to 120% [9]. In order to know how this factors affects the voltage selectivity achievement under high PL values various  $OD_{limits}$  are studied. In order to integrate new LV network to the existing network the system has to maintain reactance  $X_{DG}$  at each DG unit same as in the existing network.

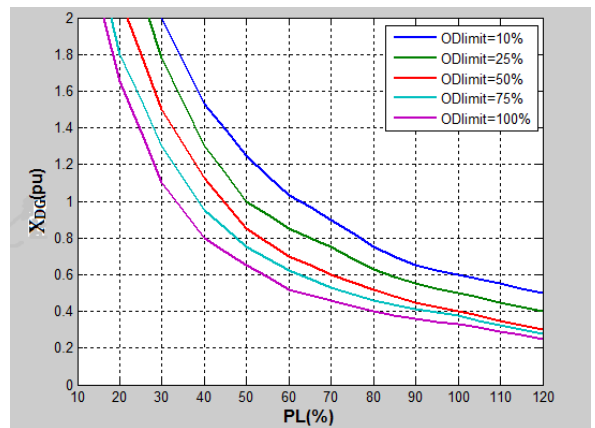

**Fig-5:**  $X_{DG}$  optimum value as a function of PL for different  $OD_{limit}$

From the fig-5 it is clear that the  $X_{DG}$  at each DG unit has obtained same as in the previous network(11) and higher  $OD_{limit}$  makes possible the achievement of voltage selectivity under a wider range of PL values. By taking one example, if  $OD_{limit}$  is set equal to 100%, high-voltage selectivity may be achieved under any PL value between the acceptable ranges.

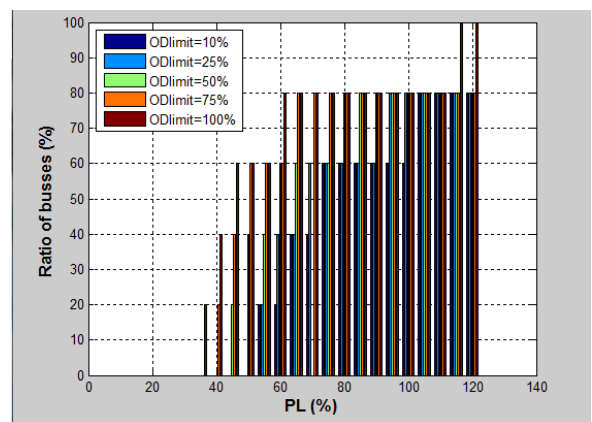

**Fig-6:** Percentage of buses with voltage higher than 0.1pu as a function of PL, with  $OD_{limit}$  being a parameter, in case of a short circuit at 1LV1 bus

In case of a short circuit at 1LV1 bus fig-6 presents the percentage of buses with voltage higher than 0.1pu as a function of PL, with  $OD_{limit}$  being a parameter. Short circuit at 1LV1 bus is the worst possible case regarding the voltage levels. The results in fig-6 agrees with the ones in fig-5, highlighting the fact that as  $OD_{limit}$  increases more buses may preserve adequately high-voltage levels.. Assuming that this disturbance is temporary, the selection of  $OD_{limit}$  and the respective optimum  $X_{DG}$  value can be set so as to preserve a critical amount of DG-PVs in operation, especially for high PL values.

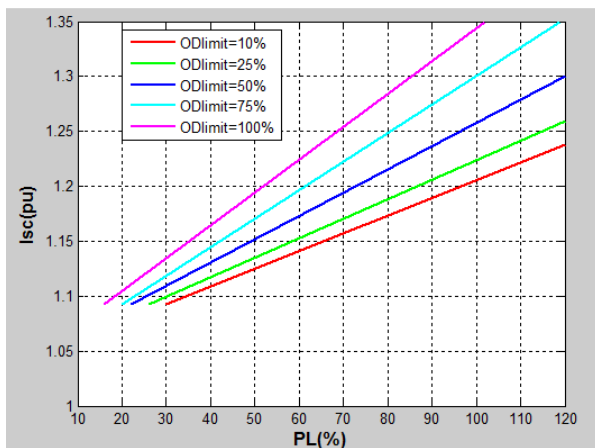

**Fig-7:** Impact of optimum  $X_{DG}$  and PL values on the ratio of bus short-circuit currents in line 1, in case of a three-phase short circuit at 1LV5 bus (worst case)

Finally, an important outcome of this optimization process is that the aforementioned results, regarding the  $X_{DG}$  optimum value, do not remarkably violate the protective limits of the distribution network. This is shown in Fig-7, where the ratio of 1LV5 bus short-circuit current is presented as a function of the PL value, with  $OD_{limit}$  being a parameter. Particularly, the ISC varies between 1 and 1.35. The ISC value comes below 1.25pu when  $OD_{limit}$  is lower than 20%. Therefore we have to implement proposed design of DG-PV with minimum reconfigurations in the network protection scheme. As long as  $OD_{limit}$  is higher than 25% it can be deduced that the restriction of  $I_{sc} < 1.25pu$  still permits the achievement of voltage selectivity under a wide range of PL values.

From above optimization results it is clear that the ideal characteristics fig5 and fig6 are achieved and after adding a new LV network to the existing network short circuit current  $I_{sc}$  below 1.25pu still allow the system to maintain voltage selectivity at higher penetration level has shown in fig-7.

#### 4 CONCLUSION

In this paper the optimum design of low voltage distribution network are connected with DG-PV units are presented and applied with LVRTC scheme in order to supply the generated power from PV to distribution network at higher penetration level. The simulation results exhibited the according affects of the impedance of the DG units on the bus voltages of the distributed network aftermath of the happening of the fault. On top of the all aspects the concept of voltage selectivity been introduced. In order to control the cost of the system over sizing of interfaced inverter are limited. In order to integrate new LV network to the existing network the system has to maintain reactance  $X_{DG}$  at each DG unit same as in the existing network is achieved. The optimum design with the introduction of a new LV network to the existing network shown better performance compared to existed five LV distribution network are represented through simulation results which shows significantly increase in short circuit current where  $I_{sc} < 1.25pu$  permits the achievement of voltage selectivity under a wide range of PL values. Obtained simulation result confirms the effective development of DG-PV for respective increase in PL values.

#### REFERENCES

[1] Saeedul Islam, G.M., Al-Durra, A., Muyeen, S.M., Tamura, J.: 'Low voltage ride through capability enhancement of grid connected large scale photovoltaic system'. IECON 2011 – 37th Annual Conf. of the IEEE Industrial Electronics Society, Melbourne, VIC, November 2011, pp. 884–889.

[2] Technical Guideline: BDEW (Bundesverband Deutsche Elektrizitäts- und Wasserwirtschaft) : 'Generating plants connected to the medium-voltage network, guideline for operating plant's connection to and parallel operation with the medium-voltage network', June 2008.

[3] Demoulias, C.: 'A new simple analytical method for calculating the optimum inverter size in grid-connected PV plants', *Electr. Power Syst. Res.*, 2010, 80, (10), pp. 1197–1204.

[4] Sheng, W., Liu, K.-y., Cheng, S.: 'Optimal power flow algorithm and analysis in distribution system considering distributed generation', *IET Gener. Trans. Distrib.*, 2014, 8, (2), pp. 261–272.

[5] Miret, J., Castilla, M., Camacho, A., Vicuña, L.G.D., Matas, J.: 'Control scheme for photovoltaic three-phase inverters to minimize peak currents during unbalanced grid-voltage sags', *IEEE Trans. Power Electron.*, 2012, 27, (10), pp. 4262–4271.

[6] Renders, B., Vandeveld, L., Degroote, L., Stockman, K., Bollen, M.H.J.: 'Distributed generation and the voltage profile on distribution feeders during voltage dips', *Electr. Power Syst. Res.*, 2010, 80, (12), pp. 1452–1458.

[7] Grainger, J.J., Stevenson, J.W.: 'Power system analysis' (McGraw-Hill, Inc., 1994).

[8] Christodoulou, C., Papanikolaou, N., Gonos, I.: 'Power quality assessment for autonomous residential PV systems'. 16th IEEE Int. Conf. on Harmonics and Quality of Power (ICHQP 2014), Bucharest, Romania, 25–28 May 2014.

[10] EN 50160: 'Voltage characteristics of electricity supplied by public distribution system', 2004.

[11] Ioannis I. Perpinias, Nick P. Papanikolaou, Emmanuel C. Tatakis: 'Optimum design of low-voltage distributed photovoltaic systems oriented to enhanced fault ride through capability', 2015.