

Foot Step Power Generation System Using Electronic Device

Prabhavathi K¹, Vinay Kumar K², Channakeshava P C³, Rajesh C R⁴, Puneeth Kumar C S⁵

¹Assistant Professor, Dept. Of ECE, BGSIT, Karnataka, India

^{2,3,4,5}UG student, Dept. Of ECE, BGSIT, Karnataka, India

Abstract - Electric Power generation it is one of the issues. In This generation different numbers of power resources are available, non- continual & continual, but still we cannot overcome our power needs. encompassed people population is one of the sources. In this project we are doing power generation by running or walking. energy can be generated by step on the tiles. The generated energy will be stored and then we can use it for homely purpose. This system can be place at homes, schools, colleges, where the human move around the time. When people walk on the floor or that of tiles, electrical energy is generated by using people weight. The control mechanism operate piezoelectric device, this piezoelectric device convert mechanical energy into electrical energy. When there is some oscillation, force exert by foot on floor or tiles. It can be used for charging devices e.g. laptop, mobile, etc.

II POWER GENERATION USING FOOT STEP METHOD

In this electric power is generated as non-conventional method. Thus the generation of power is by walking or running on foot step. At this time non-conventional energy is very important. This system introduces power generation using non-conventional energy which does not need any input to generate electrical output. In this conversion of force energy into electrical energy takes place. This technology is based on principle of piezoelectric effect which has ability to build up electrical charge from pressure and strain applied to them. Piezoelectric ceramics belongs to the group of ferroelectric materials. These materials are the crystals and they do not need electric field being applied.

Index Terms: Power utilization, Power generation, piezoelectric material, energy conversion.

1. INTRODUCTION

Energy is nothing but the ability to do the work. In day to day life, Electricity is most commonly used energy resource. Now-a-days energy demand is increasing and which is life-line for people. Due to this number of energy resources are generated and wasted. Electricity can be generated from resources like water, wind etc. to generate the electricity from these resources development of big plants are needed having high maintenance cost. Some other energy resources are also costly and cause pollution. They are not affordable to common people. Electricity has become important resources for human being hence, it is needed that wasted energy must have to utilize, walking is the most common activity done by human being while walking energy is wasted in the form of vibration to the surface. And this wasted energy can be converted into electricity. Using the principle called piezoelectric effect. Piezoelectric effect is the effect in which mechanical vibrations. Pressure or strain applied to piezoelectric material is converted into electrical form. This project gives idea about how energy is used on stepping on stairs. The use of stairs in every building is increasing day by day even small building has some floors when we are stepping amount of this wasted energy is utilized and converted to electricity by Piezoelectric effect. Piezoelectric effect is the effect of specific materials to generate an electric charge in response to applied mechanical stress.

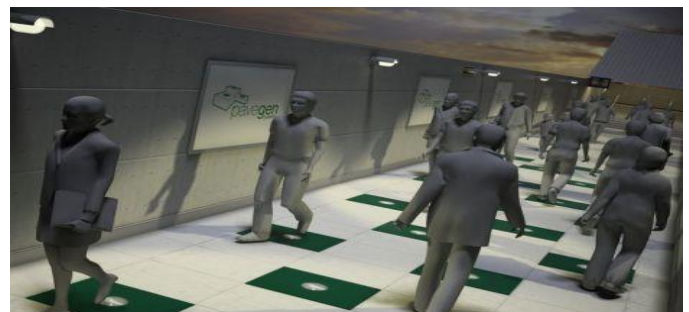

Fig -1: Power Generation Using Foot Step Method

A. Working

Key concept of working of this system is capturing unused energy from surrounding any system and converting it into electrical energy. The piezoelectric placed under insulating material like hard rubber and pressure created by foot step and water fall pressure will produce electrical energy which can be stored and used for domestic purpose. The property of Piezoelectric Material is to generate electricity when we apply pressure. It has two axis, mechanical axis & electrical axis. When we apply pressure in mechanical axis, it generates power in its electrical axis. Piezo means the generation of the electrical polarization of a material as a response to mechanical strain. This phenomenon is known as direct effect or generator effect and is applied fundamentally in the manufacture of sensors (mobile phone vibrators, lighters, etc.). In these cases piezoelectric materials, also used in actuators, undergo an inverse or motor effect,

i.e. a mechanical deformation due to the application of an electrical signal.

B. Commercial Utility:

1] Along the central crossing between London’s Olympic stadium and the recently opened Westfield Stratford City mall 20 tiles will be scattered with an estimated footfall of 30 million people in the first year.

2] In front of ticket counters and every time a passenger steps on the mats, special flooring tiles were installed and they trigger a small vibration that can be stored as energy

3] We can implement this system in the floor area of stairs, schools and colleges where thousands of students are studying.

II FOOT STEP POWER GENERATION USING PIEZOELECTRIC TRANSDUCER

Electricity has become lifeline for human population. Demand of electricity is increasing day by day. Some technology needs high amount of electrical power to perform various operations. As we know electricity is generated by some sources like water, wind etc. To generate the electricity from these resources, development of big plants or big mills is needed having high maintenance cost. As the use of energy increases, no of energy resources are generated and wasted. If the wastage of energy is rapidly increases then one day will come at that time we will face totally absence of energy.

This technology is based on principle of piezoelectric effect which has ability to build up electrical charge from pressure and strain applied to them. Piezoelectric ceramics belongs to the group of ferroelectric materials. These materials are the crystals and they do not need electric field being applied. Piezoelectric ceramics like PbTiO₃, PbZrO₃, PVDF and PZT. Most commonly available piezoelectric materials are PZT and PVDF.

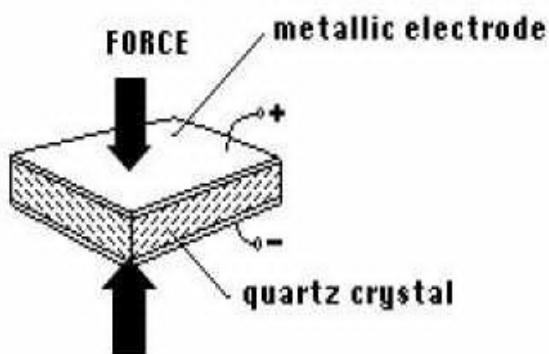

Fig -2: Working of Piezoelectric Transducer

A. Study of connections-

To give better voltage and current three PZT are connected in series. A force sensor and voltmeter is connected to this series combination. As varying forces are applied on this connection and corresponding voltages are noted. Voltage and current generated across the series connection is measured. The voltage and current generated across the parallel connection is measured. From series connection obtained current is poor and from parallel connection obtained voltage is poor. To overcome this problem rectifier in series-parallel connection is used.

B. Working-

Piezoelectric material converts pressure into electrical energy. The pressure can be either from weight of moving vehicles or from the weight of people walking on it. The produced output is in the variable form. so bridge circuit is used to convert variable voltage into linear voltage. An AC filter is used to filter out this output voltage and it is stored in rechargeable battery. Two possible connections were tested-parallel and series connections for producing 40v output. Inverter is connected to battery and battery connection provide AC load. The voltage produce across the time can be displayed on LCD.

A piezo tile capable of generating 40v. The weight applied on tile and corresponding produced voltage is referred and linear relations found.

III. POWER HARVESTING BY USING HUMAN FOOT STEP

In this paper use of piezoelectric crystal is to generate electric output from surrounding vibration. Piezoelectric materials have crystalline structure. They can convert mechanical energy into electrical energy and vice versa. The produced electrical energy from piezoelectric crystal is very low in the order of 0.2-3 volts and is stored in battery to charge controller, since it is not possible to charge 12v battery through crystal output. To increase the voltage, the boost converter circuit is used. The level of voltage ranges 12v and it is stored in 12v battery.

A. Piezoelectric effect-

They also use piezoelectric crystal. The piezoelectric crystal exhibit the piezoelectric effect. This piezoelectric effect having two properties. First one is the direct piezoelectric effect which means that material has ability to convert mechanical strain into electrical charge. Second one is the converse effect, in which the applied electrical potential converted into mechanical strain energy. That means material used as power harvesting medium.

B. Boost converter-

A boost converter is also called as step-up- converter. It is a power converter having greater output DC voltage than its input DC voltage. It is same as switching mode power supply having at least two semiconductor switches (a diode and a transistor) and at least one energy storage element. Capacitor filter is added output of converter to reduce the ripple in the output voltage. The basic principle of boost converter having two modes of operation, continuous and discontinuous mode.

C. Working-

This system arranged for the requirement of taking 230v AC from 12v DC input. This input signal given to DC to AC inverter. 12v DC voltage is given to the circuit it goes to diode D1 which produce reverse voltage then Q1 will conduct. At that time we get positive cycle of 230v in the output transformer side. Then after some seconds it gets saturated and Q2 will conduct. This switching makes reverse polarity at output side. After some seconds Q2 gets saturated and Q1 will conduct. Likewise alternating switching takes place.

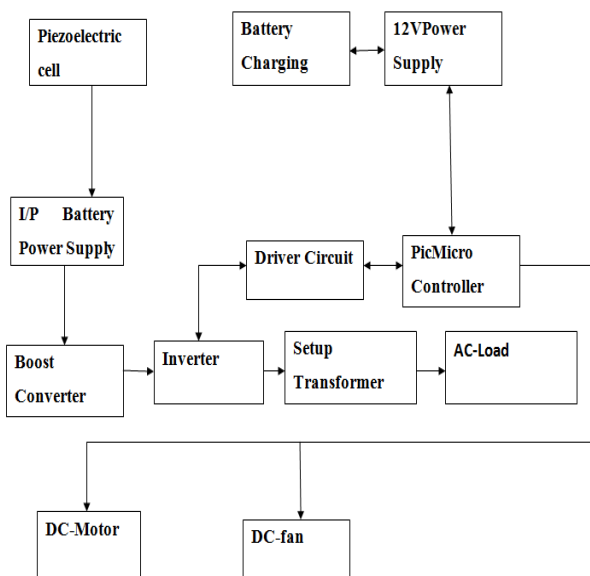

Fig -3: Working Of Foot Step Power Generation System

IV. POWER GENERATION

Today the major problem which is discussed rapidly energy crisis and ideal solution for this is adaptive renewable energy resources. Among all the energy sources like solar energy tidal energy, human population is also abundant energy resource that has not been yet normally in used. Using this resource expected amount of

energy can be generated thus it may be ideal to generate the electricity from human population.

When people walk on the floor then electricity is generated due to weight of person as this system utilizes the parameter ressure to generate energy. This generated energy is stored in the batteries .This system will generate efficient outcome if installed in populated area. Implementation of this project will turn into boon in generation of electricity from the pressure by footsteps .

The places in India where we can implement this system are roads, railway stations, bus stands where millions of people move round the clock. When people walk on the floor their body weight compresses the setup which rotates dynamo and generated energy stored in the battery to reduce external compressions responsive sub- flooring system is installed.

A. Principle

The principle of the working of this system is conversion of pressure from foot steps into rotary motion and this rotary motion is used to rotate the device like Dynamo or Sanyo coil. The amount of rotation depends upon the pressure by the weight of person walking on the floor.

B. Construction and Working

The system consists of blocks that depress slightly under pressure of human steps and which will depress the mechanical setup placed immediately after it inside the system. This consists of immovable bottom platform and compressible top platform. System also consist of four primary spring a lever assembly , large pulley, small pulley, power generator, shaft with two free wheel bearing and break arrangement.

When people walk on the floor, the floor pressed on the mechanical setup. The setup pressed due to the spring action and pulls the lever assembly which rotates one of the freewheel bearing fitted to the shaft. The shaft then rotates the large pulley which is connected to the smaller pulley through a V-belt. This smaller pulley acts as a reducer this provides more rotations corresponding to one rotation of the large pulley. This smaller pulley coupled with the dynamo (or Sanyo coil), a device that converts the energy of rotary motion into electric current and power is obtained.

This process depends on two factors , primary spring tension and type of generator used. When the pressure is applied through a foot step , ninety-five percent of the pressure applied is converted into energy in this method.

V. PROTOTYPE SYSTEM

FOOT STEP POWER GENERATION USING PIEZOELECTRIC MATERIAL

The piezoelectric material converts the pressure, stress applied to the material into electrical energy. The source of stress is from the weight of the people stepping on the stairs. As the output voltage from a single piezo-film was extremely low, thus combination of few piezoelectric is used. Two types' possible connections can be done parallel connections and series connections. The output of the piezoelectric material is not a regulated one, so variable to linear voltage converter circuit rectifier is used. AC ripple neutralizer is the circuit used to reduce the ripples from the piezoelectric output. The AC ripple neutralizer consists of rectifier and ripple filter. Again AC ripples are filtered out using ripple filter and it is used to filter out any further variations in the output and then it can be pass through regulator in order to regulate. The output of the voltage regulator is given to the unidirectional current controller. Unidirectional current controller means it allows flow of current in only one direction. Mostly used unidirectional current controller devices are as follows:

1. Diode- we already know that it allows an electrical current in one direction. It acts like a switch. A specific diode converts AC into pulsating DC hence sometimes it also called as rectifier.

2. Thyristor- A thyristor is four layer semiconductors that are often used for handling large amount of power. While a Thyristor can be turned on or off, it can also regulate power using something called phase angle control.

The output voltage from this piezoelectric is then stored in a battery through ac ripple neutralizer which does exactly opposite job of the rectifier and filter which converts the stored direct current (DC) energy in batteries back into alternating current (AC). An inverter is connected to battery to drive AC load. LCD display is used for displaying generated voltage. For this purpose microcontroller AT89S52 is used. The microcontrollers consist of crystal oscillator and which is used for its operation. The output of the microcontroller is then given to the LCD which then displays the voltage levels.

From this system we are generating energy by human footsteps using the piezoelectric effect. Piezoelectric effect is the effect which converts mechanical stress, strain, pressure into electrical energy. This idea not only overcome the energy crises problem but also helps to maintain the eco- friendly environment for generating energy.

A. Future Scope:

Utilization of wasted energy is very much relevant and important for highly populated countries in future.

1. Flooring Tiles-

Japan has already started experimenting the use of piezoelectric effect for energy generation. They implement piezoelectric effect on the walking tiles. Thus every time people steps on the tiles; they trigger a small vibration that can be stored as energy.

The flooring tiles are made up of rubber which can absorb the vibration. This vibration generates when people are walking on it. Under these tiles piezoelectric material are placed. When the movement is felt by the material they can generate the electricity. This generated energy is continually stored into the battery. Generated electricity we can use the lighting of lamp. Energy is generated by step of one man being is too less but if number of steps increases ultimately energy production also increases

2. Dance floors-

Europe is another one of the country which started experimenting use of piezoelectric crystal for energy generation in DJ clubs. Floor is pressed by the dancer's feet and piezoelectric materials makes contact and generate electricity. Generated electricity is nothing but 02- 20 watt. It depends on impact of the dancer's feet. If constant compression of piezoelectric crystal causes a huge amount of energy.

VI. CONCLUSION

A piezoelectric plate capable of generating 1V has been devised. Comparison between various piezoelectric material shows that PZT its generate how many piezoelectric placed into tiles. Also, by comparison it was found that series-parallel combination connection is more useful. The force applied on the tiles and corresponding voltage generated in piezoelectric design tiles. It is mainly installed in crowded areas. This can be used in domestic without use of any power lines. It can also be used as mobile charging, street light etc.

REFERENCES

- 1] Prabakaran R, Jayramaprakash A, Vijay Anand. "Power Harvesting by Using Human Foot Step"- International Journal of Innovative Research in Science Engineering and Technology, vol.2, issue 5, July 2013
- 2] Ramesh Raja R, Sherin Mathew. "Power Generation from Staircase (steps)"- International Journal of Innovative Research in Science Engineering and Technology, vol.3, Issue 2, February 2013
- 3] Power Generation Using piezoelectric Method

4] Itika Tandon, Alok Kumar."A Unique Step towards Generation of Electricity via New Methodology"- International Journal of Advanced Research in Computer and Communication Engineering, vol.2, Issue 1, October 2013

5] Kiran Bobby, Aleena Paul K, Anumol. C.V, Josnie Ann Thomas, Nimisha K.K."Footstep Power Generation Using Piezoelectric Transducer"- International Journal of Engineering and Innovative Technology, vol.1 Issue 9, April 2013

6] Jose Ananth Vino, AP."Power Generation Using Footstep"- International Journal of Engineering Trends and Technology, vol.1, Issue 1, May 2010