

## EYE GAZE TRACKING SYSTEM

Anita P. Ghode<sup>1</sup>, Yawale R.U.<sup>2</sup>

<sup>1</sup>Student of ME (VLSI & Embedded), E & Tc Department, Sinhgad Academy of Engineering, Kondhwa, Pune-411048,

<sup>2</sup>Professor, Dept Of E & Tc, Sinhgad Academy of Engineering, Kondhwa, Pune-411048,

\*\*\*

**Abstract**— Eye gaze tracking method is useful for physically disable people with loco-motor disabilities who cannot able to do their daily activities due to their disability. First important task is to find out the gaze point of eye then communicate this gaze point for motion of an object. Here controlled object is used as wheelchair the eye gaze movement. In Proposed system eye movement is detect by head mounted camera, output from camera will be process in Matlab to find gaze point the corresponding control signal send to motor driving circuit which control the movement of wheelchair according to eye movement of person.

**Keywords**— Eye Gaze, Gaze tracking

### 1. INTRODUCTION

The eye moment can be use as best input source for handicapped and disabled people. This paper focuses on using eyes as controller which gives command to any object. The object here chooses as a wheelchair and have possible interfaced with a video game, toy car, an entertainment system. The purpose of selecting wheel chair is that of persons who are paralyzed and therefore dependent on others for its daily activities due to loss of self-mobility. Due to Diseases or accidents peoples are lose their ability to move their voluntary muscles. Because voluntary muscle people cannot to move their body, paralysis may cause a person not move their loco motor organ such as arm, leg. Many for such disable peoples control their eye movement which can become controlling part of the wheelchair.

### 2.LITERATURE SURVEY

There are many input devices which are use to interacted with the automated devices such as joysticks, keyboards, mouse etc. But all these devices required hand movement. These input devices cannot be used by people suffering from physical disabilities. The existing devices and their disadvantages for handicap person are as categorized:

(1) Bio-potential based method-There are some special instruments which utilizes potential from user's body actions. Instrument such as Electrooculography (EOG), Electromyography(EMG)[1], and Electro

encephalograph (EEG) [2], for measuring bio-potential Search coil can be used. The search coil output can be used as input sources to computer for handicap person. Limitations of this method is that is cost and give poor gaze direction accuracy than video tracker.

(2) Voice Based method [3] in this method voice is use as input. Voice signal is converted into digital data by voice analysis. This type of system may degrade due to noise. Voices from the surrounding may affect the system performance. Accuracy of this system is very less due to background noise, variation in speaker, variation in speaking style and speed of speech etc.

(3) Motion based method [4], In this method computer is operated by the movement of the organs such as head, foot etc. Physically handicapped person required to take effort for navigation.

### 3.SYSTEM MODEL

In this system person seated on the wheelchair to develop a wheelchair that will be controlled by the their eyes. Eye tracking module is used which consist of camera to capture eye ball image. A camera is fixed to capture the image. The camera is placed so as to capture the movement of one eye allowing clear vision to the other eye. Output image from camera is processed by the MATLAB software. Once the image has been processed it moves onto the controller. A functional block diagram of the design system is given in fig. 1. In this block diagram mounted camera that will track the user eyes. Camera will take an image of the eyes that image will be processed and finally move it into controller. Motor driver system which interface to the wheelchair. Motor driver control speed and direction to enable wheelchair to move forward, reverse, left or right.

### 4. SYSTEM REQUIREMENT

**Hardware :**

**PIC Controller-** PIC16F874A is used to give command to motor driver circuit according to program fed into it.

**Motor Driver circuit**–The L293D is quadruple high current half –H driver design to provide bidirectional drive current of up to 600mA at voltage from 4.5V to 36 V.

**DC Motor**- Two Dc motor of specification 12V DC with 60 rpm required for movement of wheels of wheelchair like forward, backward, right and left.

### 5. WHEELCHAIR CONTROLLER

Wheelchair controller circuit consist two of motor driving circuit each for one wheel. Fig.2 Shows motor control driving circuit. Output ports pins of controller are connected to the driver circuit as per status of the port pins polarity across motor determine which gives direction to the motor either clockwise or anticlockwise. For forward rotation of wheelchair left wheel move in clockwise direction and right wheel move in anticlockwise direction. And for that output port pins status of controller in this state is '1001'. For Right turn of wheelchair both wheels move in clockwise direction and output port pins status of controller will be '0110'. For left turn of wheelchair both wheels move in anticlockwise direction and output port pins status of controller will be '1001'. For reverse rotation of wheelchair left wheel rotate in anticlockwise direction and right wheel rotate in clockwise direction and for that output port status will be '0101'

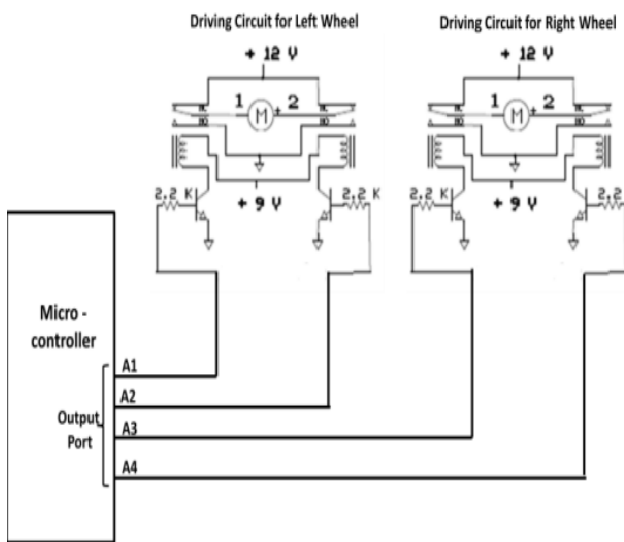

Fig. 2 Motor Drive Control Circuit.

### Get Coordinate Algorithm:

- 1] Capture image by camera.
- 2] Crop image as per Region Of Interest.
- 3] Find average of the iris and skin pixel.
- 4] Perform morphological operation such as erosion .due to which removes white noise from image.
- 5] Maximum area find out.
- 6] Find element with small area
- 7] Find centroid of the maximum area in the form of X,Y coordinates

### Eye Tracking Algorithm :

- 1] Initialization–Initialized serial port for communication to the controller.
- 2] Training - Using up, down, right, left, and center command find position of eye and calculate average position of each eye gives threshold value.
- 3] Compare current centroid co-ordinate with the threshold value at training.
- 4] As per calculate resultant position of eye wheelchair move in particular direction.

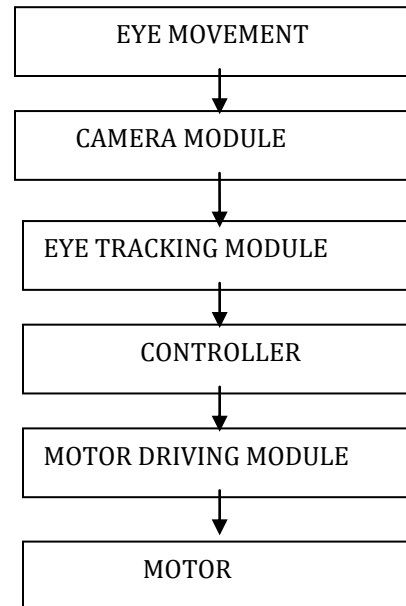

Fig. 1 Flow Chart of System

### 6. Software

For analyzed image MATLAB software for image Processing is used. Algorithm is divided into two section .first section to get coordinate of eye and second section is for eye tracking.

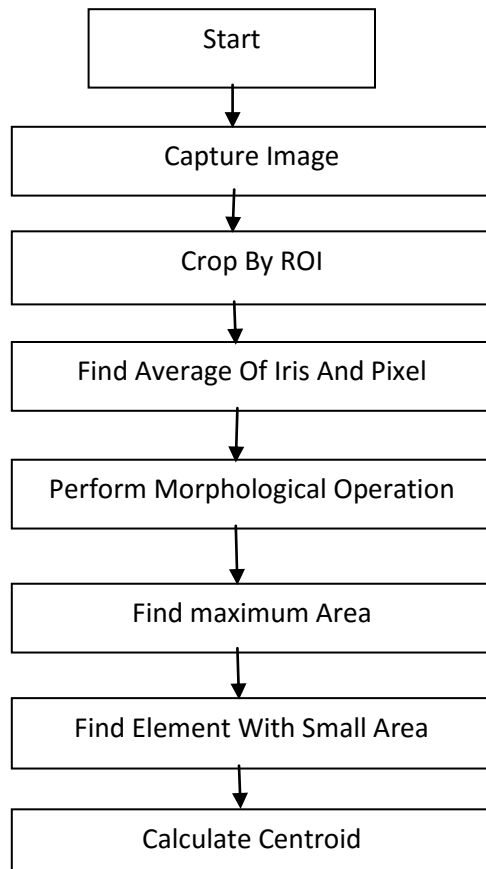

Fig. 3 Get Coordinate Algorithm

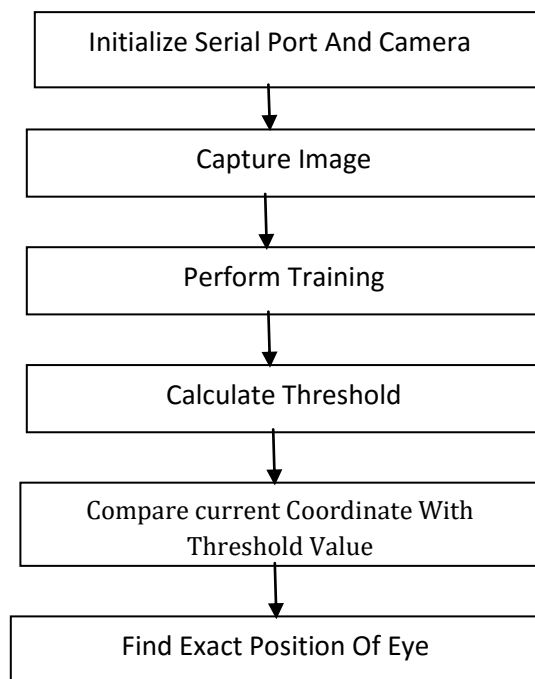

Fig.4 Eye Tracking Algorithm

## 7. RESULTS

Directions Of Wheelchair according to Position of eyeball is given below -

- Center Position- To Stop Wheelchair
- Left Position- for left turn of wheelchair
- Right Position — for right turn of wheelchair.
- Up position- Forward movement of wheelchair.
- Down position – Backward movement of wheelchair.

All Position of eye is detected as shown in following figures. Each figure is divided into six section .first section shows capture image that image is converted into gray scale image ,cropped that image as per ROI, then find threshold value. Remove noise from image and last image give the centroid from exact position of eye .

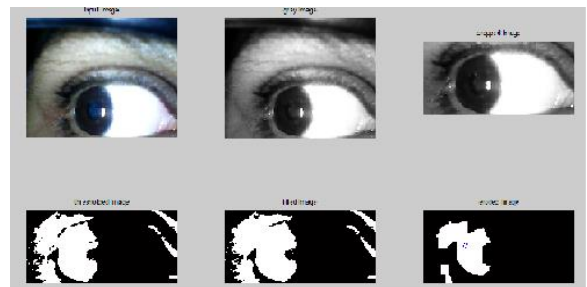

Fig. 5 left Position of Eye image And its Centroid

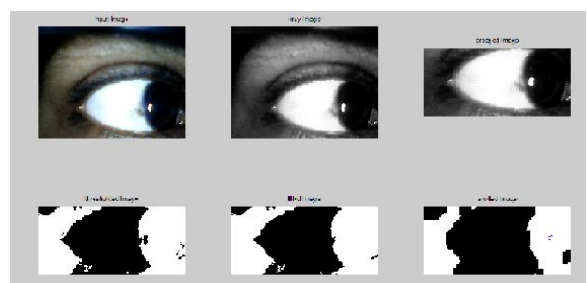

Fig. 6 Right Position of Eye image And its Centroid

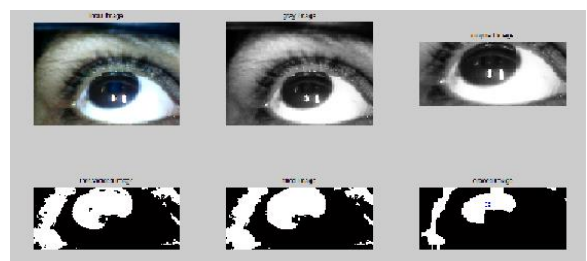

Fig. 7 Up Position of Eye image And its Centroid .



Fig.8 Down Position of Eye image And its Centroid

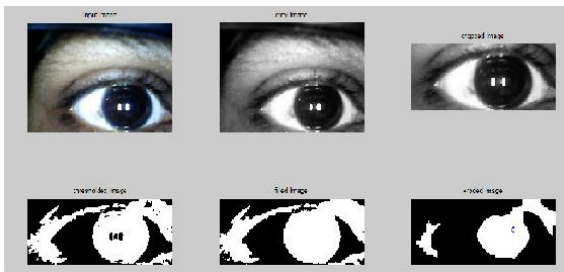

Fig. 9 Center Position of Eye image And its Centroid

## 8.CONCLUSION

In this system we present eye gaze interface with the wheelchair which help to physically handicapped people to controlled and perform their daily activities without depend on the others. This system is very useful to the society which gives better lives to physical disabled persons.

## REFERENCES

- 1] KT.V.Gratten, A.W.Palmer and S.R.Soller"Communication By Eye Closure-A Microcomputer Based system for Disabled"IEEE TRANSACTION For biomedical Engineering Vol. BME -33 No.10.
- [2] Q.X.Ngyuyen and S.Jo,"Electric wheelchair control using head pose free eye gaze tacker",Electronics letter,Vol.48 No.13,21st June 2012.
- [3] Rory A.Cooper, "Intelligent Control Of Power Wheelchair", IEEE Engineering medicine and Biology 0739-51 75/95,july 1995
- [4] Djoko Purwanto, Ronny Mardiyanto, koheri Arai" Electrical Wheelchair with gaze directon and eye blinking " ,Artif Life Robotics,14:397-400, May 18,2009