

# Novel High Voltage Buck Boost Converter

Prashant Kumar Srivastava<sup>1</sup>, Prof. Madhu Upadhyay<sup>2</sup>

<sup>1</sup>M.Tech Power Electronics(NRI,Bhopal)

<sup>2</sup>Prof. Madhu Upadhyay(H.O.D(Electrical&Electronics Engg.NRI,Bhopal))

\*\*\*

**Abstract** – This paper presents a new high efficiency buck boost dc-dc- converter with low voltage renewable energy resources. The proposed converter utilizes a low voltage DC supply and boost it to required dc voltage. In this paper PI controller is used with snubber circuit. The result are that there is very less power loss and the efficiency of the system is high. In comparison with the conventional buck boost converter.

## 1. INTRODUCTION

In modern world the cost of producing energy with nonrenewable energy source is increasing day by day and there is constant threat of limited amount of availability of it, so we have to switch to different energy sources like renewable energy sources. A dc-dc converter with is very essential now as it can be used to convert low voltage to required high voltage and we can say that conversion of a regulated dc voltage from unregulated dc voltage. An unregulated dc source may be from output of rectified solar cell or battery etc. the sources can be varied but the main objective is to get the input and convert it into required output with better efficiency and minimal loss of energy. There are many ways to convert dc-dc but buck boost dc-dc converter has a better current driving capability and has good efficiency. Although many different design have been proposed to improve the efficiency of the converter an to achieve high voltage gain such as using switched capacitor and a coupled inductor.

The basic circuit of buck-boost converter is shown in fig.1. The output of converter is controlled by closed loop and alternating its MOSFET (switch) gate signal. PI controller is used as it is more widely used for industrial application. Conventional high voltage converter without transformer cannot provide such a high voltage. In high voltage dc-dc converter coupled inductor is used to improve the voltage gain, snubber circuit to absorb stray inductance.

### 1.1 CIRCUIT CONFIGURATION

There is widely use of power semiconductor in power electronics. Snubber circuits are used across the semiconductor devices to improve performance and to improve protection. It can do many things:

- Minimizes voltage or current spikes.
- Limit current and voltage variation.
- Through the switch to a resistor or a useful load it transfer power dissipation.
- Minimizes the total losses due to switching.

- Reduce EMI by damping voltage and current ringing.

Out of vast variety of snubbers the two most common are the resistor-capacitor(RC) and the other is the resistor-capacitor-diode(RCD). They have been used in many industrial applications.

The widely used general conventional buck-boost is shown in Fig. 1. The output voltage of the converter is also regulated by the PWM control of the switch S. One is the continuous conduction mode (CCM) of dc current and another is the discontinuous conduction mode (DCM) of dc current. In the discontinuous mode of the turn-on of the switching device is a ZCS. On the other hand, the device must be switched off at a maximum inductor current. So to relieve the device's turn-off stress, in parallel with the switch of the conventional converter a snubber circuit is connected. However, the efficiency of the conventional converter is very low due to the power loss of the snubber circuit.

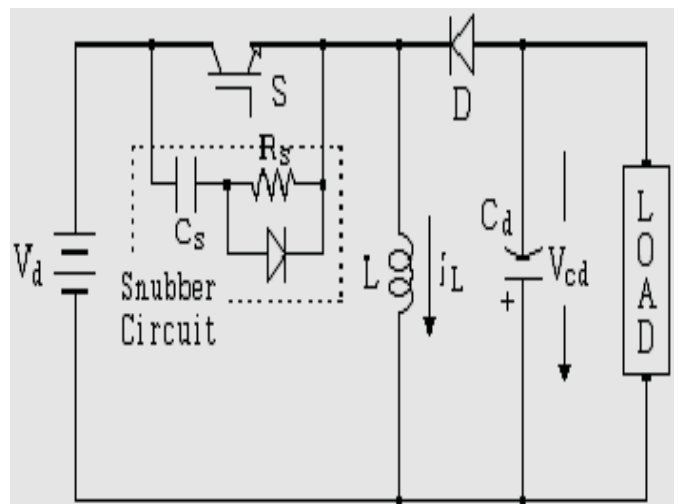
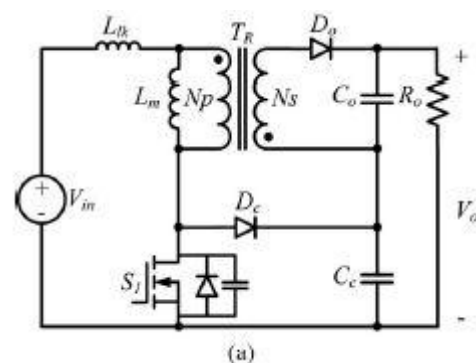

Fig. 1. Conventional buck-boost dc/dc converter.



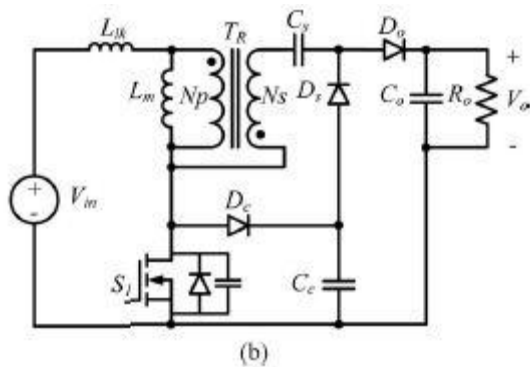

Fig. 2. High step-up dc-dc converters using coupled-inductor and switched-capacitor techniques. (a) High-step coupled-inductor roboost dc-dc converter. (b) High step-up dc-dc converter with coupled-inductor and switched-capacitor.

To improve the efficiency, a new buck-boost dc/dc converter with high efficiency is proposed in this paper and is shown in Fig. 3. The proposed buck-boost dc/dc converter is composed of controlling devices, Series LCR and snubber circuit with MOSFET. The snubber circuit is used to minimize the variation.

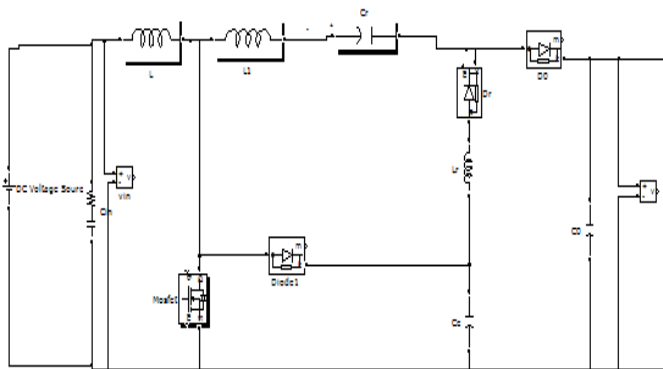

Fig. 3. Proposed buck-boost dc/dc converter.

The switching devices in the proposed converter are operated with the soft switching in MOSFET (Metal Oxide Semiconductor Field Effect Transistor). The MOSFET transistor is a semiconductor device which is widely used for switching and amplifying electronic signals in the electronic devices. The MOSFET is a 3 terminal device of source, gate, and drain. The MOSFET is the most common transistor and which are used in both analog and digital circuit. To make the MOSFET works width of a channel should be varied along which charge carriers flow (holes and electrons). Through source the charge carriers enter the channel and exits through the drain. The channel width is controlled by the voltage on an electrode is called gate which is located between the source and drain. In the MOSFET near an extremely thin layer of metal oxide is insulated from the channel. For applications there is a

different type of MOSFET which is used as per the requirement.

Snubber Resistor, $R_s$	500 $\Omega$
Snubber Capacitor, $C_s$	250 $\mu\text{f}$
Resonant Inductor, $L$	2.5 mH
Resonant Inductor, $L_r$	0.5 mH

By increasing the total power delivered decreasing the losses in the circuit the capacitive and inductive energy can be transferred simultaneously to the high voltage dc bus. The magnetic core can be used more effectively and smaller magnetic can be used by the energy transferred from the hybrid transformer which combines the modes where the transformer operates under normal conditions and where it operates as a coupled-inductor. A smaller current ripple is caused by the continuous input current of the converter cases than that of previous high boost ratio converter topologies that used coupled-inductors. The input capacitance can be reduced by the lower input current ripple in that and it is easier to implement a more accurate MPPT for PV modules. Because of the reduced input current RMS value through the primary side the conduction losses in the transformer are greatly reduced. The voltage stress of the active switch is always at a low voltage level and independent of the input voltages. Due to the introduction of the resonant portion of the current, the turn-off current of the active switch is reduced. As a result of the decreased RMS current value and smaller turn-off current of the active switch, high efficiency can be maintained at light output power level and low-input voltage operation. Because of the resonant capacitor transferring energy to the output of the converter, all the voltage stresses of the diodes are kept under the output dc bus voltage and independent of the input voltage.

### 1.2 OPERATION OF CONVERTER

Fig. 4 shows the Simulink Schematic of Buck- Boost converter with analog PI controller. The output of the proposed diagram is again send back to the PI-controller which again with the reference required is controlled and a switching pulse is generated to give the required output. In this proposed schematic diagram the input provided can be from any dc source either a storage devices or a continuous dc source provider through a generation or a grid for reference in this 100V dc sources in provided which is then converted to 500v dc.

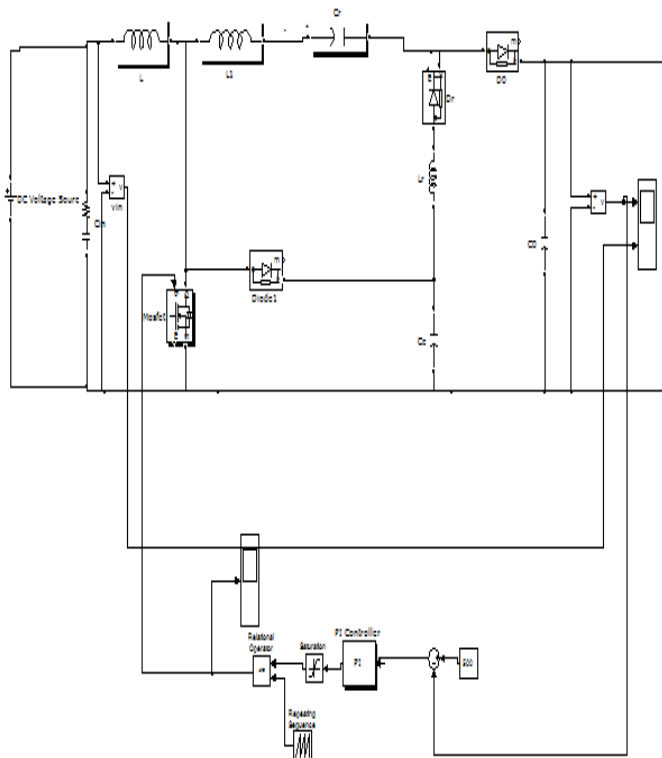

Fig -4: Converter with Pi controller

Fig. 5 shows the input provided to the proposed circuit diagram and Fig. 6 shows the output of the proposed diagram.

### 3. CONCLUSIONS

In this paper a new buck-boost dc-dc converter with high efficiency is presented. To achieve the soft switching of the controlling switches, the proposed converter applied a partial resonant circuit using a step-up inductor and a loss-less snubber capacitor, which is the partial resonant circuit designed for replacement of an energy storage inductor and a snubber circuit which have been used in a conventional buck-boost converter, and then the configuration of the proposed converter was simplified. The accumulated energy in the loss-less snubber capacitor was regenerated into the input power source by the partial resonant operation. The partial resonant operation also conducted to the reduction of the losses and stresses of the resonant devices. As a result, the proposed buck-boost dc/dc converter was that the switching power losses were very low and the system efficiency was high in comparison with the conventional buck-boost dc/dc converter.

### REFERENCES

- [1] Bin Gu, Jason Dominic, Jih-Sheng Lai and Chuang Liu, "High Boost Ratio Hybrid Transformer DC-DC Converter for Photovoltaic Module Applications" IEEE TRANSACTIONS ON POWER ELECTRONICS, VOL. 28, NO. 4, APRIL 2013.
- [2] Dong-Kurl Kwak, Seung-Ho Lee, and Do-Young Jung, "A New Buck-Boost DC/DC Converter of High", 978-1-4244-3557-9/09/\$25.00c2009 IEEE
- [3] F. Blaabjerg, Z. Chen, and S. B. Kjaer, "Power electronics as efficient interface in dispersed power generation systems," IEEE Trans. Power Electronics, vol. 19, no. 5, pp. 1184-1194, sept, 2004.
- [4] Saurabh, Dr. P.K.Saha, Dr. G.K.Panda, "A High Step up Boost Converter Using Coupled Inductor with PI Control", 10.15662/ijareeie.2015.0401026
- [5] Abhinav Dogra, Kanchan Pal, "Design of Buck-Boost Converter for constant voltage application and its transient response due to parametric variation of PI controller," IJRSE vol. 3, issue 6, june 2014.
- [6] S. Kanimozhi, Dr. V. Rajini, "Implementation of a Non-Isolated, High Gain ZVS/ZCS DC-Dc Converter", IJETAE, volume 4, issue 5, May 2014.
- [7] Y. Xue, L. Chang, S. B. Kjaer, J. Bordonau, and T. Shimizu, "Topologies of single-phase inverter for small

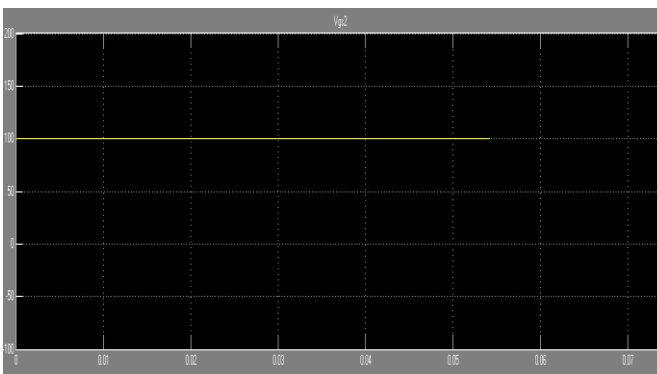

Fig -5: 100v DC input

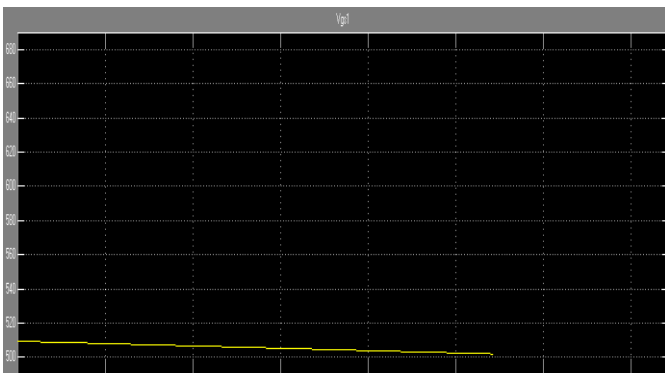

Fig -6: 500v DC output

distributed power generators: An overview," IEEE Trans. Power Electron., vol. 19, no. 5, pp. 1305–1314, Sep. 2004.

- [8] Y. P. Hsieh, J.-F. Chen, T. J. Liang, and L. S. Yang, "Novel high step-up DC–DC converter with coupled-inductor and switched-capacitor techniques for a sustainable energy system," IEEE Trans. Power Electron., vol. 26, no. 12, pp. 3481–3490, Dec. 2011.

## BIOGRAPHIES



Prashant Kumar Srivastava,  
B.E in Electrical Engineering  
from RTMNU.



Prof. Madhu Upadhyay,  
Associate Professor &  
HOD in NIIST, Bhopal