

Planning & Scheduling of Commercial Building Using Microsoft Project & Application of Principles of Theory of Constraints for Achieving High Efficiency in Construction Project

Manisha N. Ghotnekar¹, Shashank U. Vanakudari²,

¹P.G Student, Department of Civil Engineering, Jain College of Engineering, Belagavi.

²Assistant Professor, Department of Civil Engineering, Jain College of Engineering, Belagavi

Abstract - The main goal of this paper is the representation of comparative survey of constraint's theory and critical chain project management's applications, which is well established according to the critical path method for the programme planned and scheduled in MS project software for the construction of project with commercial essence. The theory of constraints renders the ways to achieve the control over effective duration concept. CCPM is one of the applications of TOC to the management of project which outlines the core restriction as activities in the form of chain with length of project with the usage of buffer management whose objective is the give strict plan of construction that guards contrary to suspicions and cut down the impending impact on changes of construction by management of buffers effectively in planning, scheduling, and controlling to accomplish tasks without wasting time. Henceforth TOC, gives way for the awareness of constraints that are faced at the time of construction in order to reach the high performance and also helps to reduce the time taken to construct the project undertaken by following the five procedures of TOC with applications of CCPM and buffer management. The impact of the above said concept has to be well understood so that it can be appropriately adopted in forth coming projects for better provision on time in relation to its efficiency.

Key Words: Theory of Constraints, Critical Chain project Management, Buffer Management and Microsoft Project.

1. INTRODUCTION

As we all know that we face many constraints in every working environment and with the more complexity in construction project, we need to be much sure about the planning and scheduling in construction management. If resources required are limited, it is very difficult for the schedule planning and controlling in a construction project. Sometimes we may not know that constraints exist and we lean to ignore those constraints and concentrate more on completion of project goal. Even if any organization is small or big, does stand alone or multiple projects, many of the projects are difficult to control and manage due to uncertainty and different commitments like date or budget. Most of the projects stop before they get completed which wastes the money, time and effort given for the project. Generally, the main objective of planning, scheduling and

controlling of a construction project is successful completion of every single task in the construction work. Constraint can be defined as anything such as technical sequencing, temporal/spatial limitations, and safety/quality concerns which restrict or prevent the project from achieving its goal. In its field complex construction projects such as industries, large substructure works like underground works and building projects like airports, campuses, hospitals etc. are all subjected to various adverse impacts on overall execution of project. Before the clearer topology constraints of interdependencies and material connectivity between various customs, other constraints should be satisfied before the work progresses in the field. They exist in every working environment even though every project will have at least one constraint which represents relationship between any process and a particular object, which prevents the project from achieving its goal. They may cause undesirable results or may not be contributory in the achievement of the goal. Constraints should be managed or the impact must either be reduced or eliminated.

Constraints are generally classified into two main classes, one as Internal and the other as External. Constraints that are under the rheostat and are present inside the system are known as internal constraints. This indicates whenever there is more demand in the market and the system is unable to fulfill it, so required actions has to be taken to overcome this constraints. External constraints are lesser under control and are outside the system. This clearly means that the system capacity slacks to achieve the so called external constraints and their deeds undertaken will somewhat decrease undesirable effects instead of constraint elimination. Constraints with advanced impact are the root issues and lower impact constraints are with relatively lower impact which relates to environment factors on buildings project performance. Theory of Constraints is applied to critical chain method which offers advanced methodology to handle the connected hazard and uncertainty. In the way to minimize the possibilities of risk and the occurring uncertainty buffer management used, and it also gives away the report stating the ratio of impacts. Now a days just the scheduling does not lead to accuracy, to defeat this problem the latest schedules like CCPM or buffer management is used. Hence by the documentation of this method, we clearly

understand that the heavy expense will be reduced within the expected time.

1.1 Current Problem

As we know that usually projects fails at an alarming frequency. Numerical evaluations show that projects more than thirty percentage got failed in advance to completion, by deteriorating overall money, time also strength over them. Hence that failed projects take in more cost every year which also happen in entirely kinds of projects also humanities. Every project has an aim and satisfying and to obtain such project aim three necessary conditions are required as follows

1. The project scope should set a least measures to its consequences.
2. Supreme price should be fixed by the project budget.
3. Extreme period should be fixed in the project schedule.

The above three necessary conditions are depended on each other. More the project consumes time, more it costs. More the project cost, more the project consumes time. The more projects consume time, the more opportunities occur to change the project scope. The cost and schedule of the project will increase if the project scope changes. One of the main constraints of the project is the period of time in which it should be completed, which is due to the following reasons:

1. A delay in implementation of project in a high increase of cost contingency.
2. A delay in implementation of project has negative consequences about cash flow, related mostly to the increase of general or overhead costs.
3. Change in scope of the project, change in technology of project tasks implementation or change in the functionality in the matter of project activities expectations may occur in the situations of extending completion time of the project and the expectations of stakeholders are modified.

In construction activities there will a clear correlation between the completion time of project and its probability. Beyond the directive project deadline has negative financial consequences, such as delay in achieving proposed benefits, postponing profit and repeatedly loss of and share in market. The consequences of delay in construction project and investment may be significantly more than the exceeding budget only.

2. METHODOLOGY

2.1 Theory of Constraints

The constraints theory (TOC) established by Goldratt is a method marked in detecting and eliminating constraints in procedures which are restricting system's objectives. A constraint is anything which restricts the system or entity from moving or achieving to its goals while one of the

interesting features of Constraints theory is one it essentially arranges the activity perfection and top significance is continually given to the present restriction. TOC offers extremely focused methodology solution when there is urgent need for improvement in environment. The effective implementation of Theory of Constraints will provide the following benefits.

1. Fast improvement in progress
2. Increased profit
3. Enhanced capacity
4. Reduction in lead time
5. Inventory reduction

The method of current development initiates with a pure identification of a systems aim likewise the instituting of performance measurement parameters that are directly associated to the systems aim. The TOC delivers tool for assessing the results of the method earlier, throughout and also when it runs. TOC concentrates on the restrictions of few dynamic constraints that bound the success of the system. The time period in which a project should be completed is considered as one of the core constraints, which is due to the following three main reasons:

1. The delay in project implementation has negative consequences regarding income, related primarily to the rise in overhead cost (general cost).
2. The delay in the project implementation also results in very high increase of price contingency.
3. The expectation of stake holders are modified and in the condition of extending project completion times or project selections that might occur expectations to vary the scope of the project, and modifications in the technology of implementing the project task or modification in the functionality of the focus of project activities.

In command to achieve current development within the situation of physical constraints in construction projects and for the improvement of performance, the TOC establishes a five step decision process as follows

Step 1. Recognize the organization restriction: In this step a organization recognize which part founds the weakest relation and regulates whether it is a physical restrictions or a policy connected matter.

Step 2. Adopting a method which exploits the restriction: Organizations exploit "the restrictions by exploiting similar compelling part without obligating to real expensive changes and/ or advancements.

Step 3. Subordinate everything else: With a assumed tie for exploiting the restriction, organizations modify the rest of the organization to change the limitation to inform at most effectiveness and then assess the results to inspect if the restriction continuous to hold back system presentation. If it is, the organization lasts to step 4. If it's not, the restriction has been removed and therefore the organization skips fast to step 5.

Step 4. Assessment of the restriction: If an organization influences step4, it means that step2 and step3 where not satisfactory in removing the restriction. At this fact, the organization estimates restrictions by taking no matter what action is required to remove it. This might involve major changes to the current system like restructuring. Capital improvement or divestiture. Since these usually need a considerable up-front investment, the organization should be certain that the constraint cannot be broken in step1 through three before proceeding.

Step 5. Back to first step1: Look out for inactivity. When a control is broken, the organization once again repeats all steps everywhere, looking for the next object limiting the system performance. At an corresponding time, it monitors however changes related to succeeding restrictions which may impact the restraints that are already broken, therefore preventing solution of inertia.

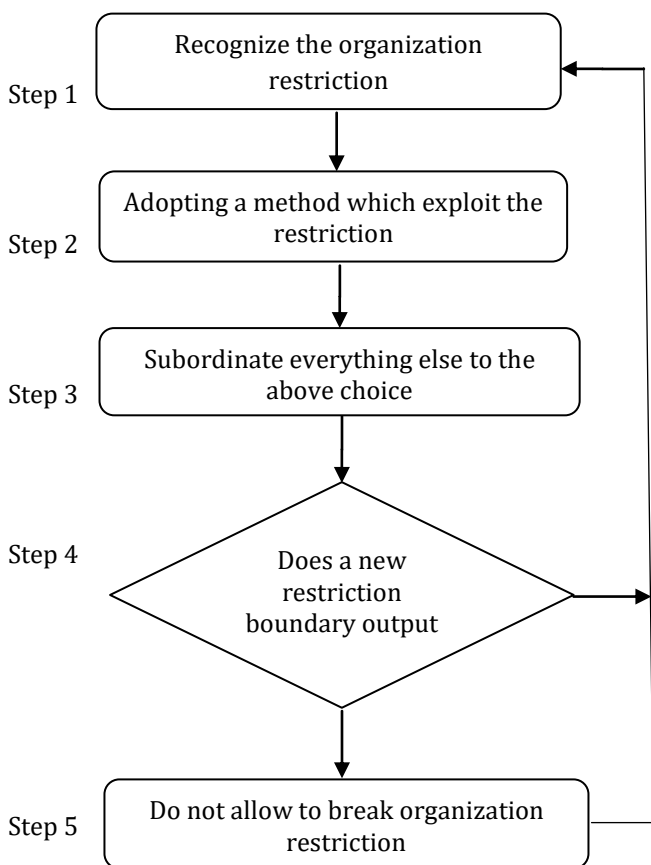

Fig -1 Flow chart of Five Steps Represent the TOC Approach

There are easy ways to identify the physical constraints and to examine them in regard to the markets real demand which includes the following: manufacturing constraints, raw material constraints, equipment constraints, input restraints, staff limitations, process limitations and similar mechanisms.

2.2 Critical Chain Project Management

CCPM is derived from the Theory of Constraints and was developed in 1997. The method is described by “Critical Chain” (Goldratt, 1997) and apply the Theory of Constraints to offers an enhanced approach to manage the associated risk and uncertainty in the project to achieve performance in project schedule management. The critical chain is the longest chain and determines the lead time of the project. Basically the method describes how to combat stretching out task duration estimates, caused by avoiding task uncertainty. Buffer management is introduced in CCPM in order to control uncertainties with respect to project timing. Critical Restraint methodology is a program grid analysis technique that receipts into consideration of assignment dependences, restricted supply accessibility and buffers. As in the case of Critical Chain Management initial step is identifying set of activities that leads to longest track to project achievement that are known as critical chains. It may be longer than CPM program because it includes resources into consideration. Next step is use efficient buffer management for limiting the project schedule by decreasing the activity period approximations. CCPM concentrates on eliminating the program delays, overestimation of task period and wastage of interior buffers correspondingly.

2.3 Buffer Management

Goldratt's critical chain methodology originated Theory of Buffer management for planning program. Goldratt titles that each duration approximations have safety period that are wasted many a times in three ways which is adequate buffer designed. He competes that the assemblies of programs itself is additionally accountable for unwanted of safety time. When more task come together at one point than delays are handed however gains don't seem to be. Instead of permitting every task to possess some safety, this approach recommend to drag out all the available safety in every individual task and allocate them most likely time and aggregates all the safety ultimately of the project that act as complete project buffer. Similarly it also offers feeder buffers at every point wherever non critical chain nourishes into the critical chain.

Buffer management eliminates the buffer from the activity approximation, thereby making a violent activity approximation. The setting of violent activity goals can usually lead to a decrease in activity period. For safety in terms of appropriateness, 3 buffers are announced to a program: a project buffer, feeding buffer, and resource buffer. Although it is assumed that the announced buffers and shorter length of tasks will not lead to a modification of the growth of the critical path. Particularly, “Activity period uncertainty”, “path period uncertainty”, and “resource uncertainties” are 3 types of uncertainties in project design and planning. In demand to decrease those uncertainties, these buffers are utilized and used within the CCPM with

added times to protect what's necessary to the achievement of that project.

2.4 Buffer Management in Construction

Buffer management is used to create valuation of feeding and buffers replacement concerning to the tasks and projects in order to deal with indeterminate case in construction projects. It will deliver a vibrant vision of increasing in impact of danger for performing of project. Compared with CPM method, critical chain involves the concern of resource constraints and it concentrates on effect of vagueness organization. This management throws light on the practice of buffer managing without deteriorating crucial period in construction project routine. Moreover, the survey concludes the scenario applying critical chain management in construction. The following diagram clearly elaborates the CCPM applications in construction. As mentioned in the above context, three different estimated buffers are incorporated in stream of CPM method, and the related techniques are convoluted in the below displayed figure.

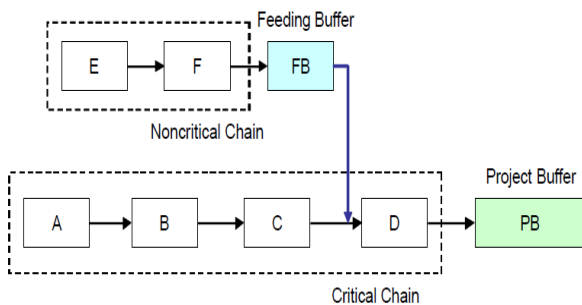

Fig-2 The Application of Buffer in Critical Chain

At the last critical chain activity at the projects finishing line allocation of the project buffer is done to defend schedule against clog. Feeding buffer comes into its form to defend critical chain compared to clog among critical chain and noncritical chain depending on their chains of feeding. Buffer of resources comes into frame to certify that they are assessable in fact required for the safe guard of the schedule and it also help to protect resource availability without adding extra time to the chain.

If the project gets finished before the planned program which means the buffer is increasing. On the other hand it indicates that the project is likely to be delayed if buffer gets decreased. The main procedures below explain the applications of buffers in construction projects:

- Step 1:** By the means of CPM method construction schedule is planned.
- Step 2:** The protective estimate for every activity is identified and defined.
- Step 3:** The sensible estimate for every activity is identified and defined.

Step 4: Based on steps 2 and 3 eliminate the safety duration from each activity.

Step 5: Identify the longest chain of relied tasks, as a critical chain for the predictable schedule that gets recognized in step 4.

Step 6: At the final stage of the critical chain, insert the project buffer.

Step 7: During noncritical chain integrating with critical chain feeding buffers are inserted.

Step 8: To certify the activity to availability of resource buffers are inserted.

3. CONCLUSIONS

To have a noble understanding of the recognized constraints at the development stages, and proposal for the certification of constraints in significant project planning program and schedule as well as during operation stage, the organization should be conscious of the constraints that meet by tracing of the growth. The Theory of Constraints facilitates the examination of norms primary outdated developed rules, policies, and measures and focuses on the few serious constraints that restrict the achievement of the organization. The status of the projects in terms of data, values and visuals has been obtained by using MS project software and the corrective measures on the constraints occurred in the project schedule are solved by application of TOC, Critical Chain Management and management of buffer to ensure the success of projects. The procedure of buffer in TOC and Critical Chain highlights laid on finishing activities lacking wasting time. It allows monitoring and having a fine grip over project schedule and can be utilized in order to reduce total project duration without any extra resource. The planning and scheduling of project using MSP, which portrays total duration of 989 days for completion considered. After applying principles of Theory of Constraints (TOC) the project duration reduced to 888 days. Hence TOC provides the concept for achieving effective duration control by managing the buffers in scheduling planning and control to achieve significant improvement resulting in higher efficiency.

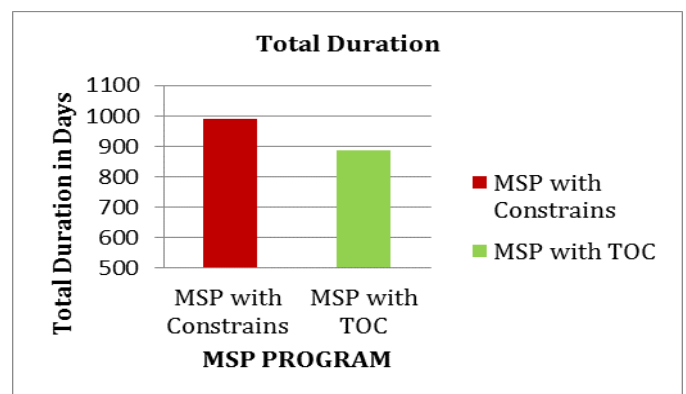

Chart -1: Comparison of constraints and theory of constraints

According to the study, The Theory of Constraints had been successfully used and is an vital tool to help in the provision of a successful project. Moreover shorter duration of the project can be accomplished by use of Critical Chain and management of buffering can be well applied in construction projects without dense up costs and also the use of buffers management in project planning will recover the effectiveness precisely in the planning phase of construction.

REFERENCES

[1] Bikram Nepal (2014) Time Management in Projects: Tools, Techniques and Methods.

[2] Ch. Lakshmi Tulasi, A. Ramakrishna Rao (2012) Review on Theory of Constraints.

[3] Chotchai Charoenngam, Planning And Scheduling Consideration and Constraints In Automated Construction Environment.

[4] Ellen lau, janet jiahui kong, Identification of constraints in construction projects to improve performance.

[5] Gary P. Moynihan (2014) Application of the Theory of Constraints for Capacity Requirements Analysis.

[6] Goldratt, E. M. & Cox, J. (1989) Chapter 4: The importance of a system's constraints. The Theory of Constraints Journal, Avraham Y. Goldratt Institute, New haven.

[7] H. Steyn (2001) Project Management Applications of Theory of Constraints beyond Critical chain scheduling.

[8] Jan, Shu-Hui, Ho, S. Ping (2006), Construction Project Buffer Management in scheduling planning and control.

[9] Krystyna Araszkievicz Application of Critical Chain Management in Construction Projects Schedules in a Multi-Project Environment.

[10] Lawrence P. Leach (2000) Critical Chain Project Management.

[11] McMullen, T.B. (1998). Introduction to the Theory of Constraints (TOC) Management System.

[12] Maryam Mirzaei, Victoria J. Mabin. Exploring Constraints in Projects.

[13] Malvika.Rajeevan, R.Nagavinothini (2015) Time Optimization for Resource-Constrained Project Scheduling Using Meta-Heuristic Approach.

[14] Nanfang Cui (1997), The calculation of buffer size considering activity schedule risk.

[15] Ron Winter, PSP, F. Burak Evrenosoglu,(2011) MS Project For Construction Schedulers.

[16] Siddesh Pai & S.Giridharan, Application of Theory Of Constraints And Critical Chain Method For Project Management In Ultra Mega Power Projects.

[17] Steven J. Balderstone and Victoria J. Mabin (1990). A Review of Goldratt's Theory of Constraints (TOC) – lessons from the international Literature.

[18] T. Subramani¹, D. S. Stephan Jabasingh, J. Jayalakshmi Analysis of Cost Controlling In Construction Industries by Earned Value Method Using Primavera.

[19] Ted Blackmon, Rekul Saxena, and Linguang. A Conceptual Framework .For Total Constraint In Construction

[20] Victoria Mabin, Goldratt's "Theory of Constraints" Thinking Processes: A Systems Methodology linking Soft with Hard.