

Performance Evaluation of MC-CDMA for Fixed WiMAX with Equalization

Avneet Kaur¹, Dr. Vinit Dhaliwal²

¹M.Tech., Dept. of ECE, GNDU, RC Jalandhar, Punjab, India

²Assistant Professor, Dept. of ECE, GNDU, RC Jalandhar, Punjab, India

Abstract - Multi Carrier-Code Division Multiple Access (MC-CDMA) is a new RF technology which is becoming prominent in the field of wireless communication. It is providing high speed data rate in new wireless communication systems. MC-CDMA is formed by combining two technologies: Orthogonal Frequency Division Multiplexing (OFDM) and Code Division Multiple Access (CDMA). MC-CDMA is used in WiMAX, Long Term Evolution (LTE), and Digital Communications. Since it is a wireless communication system therefore its generated signal will be affected by the characteristics of the wireless channel. In this paper Rayleigh fading channel and Rician fading channel models with SUI channel model parameters have been used for the analysis. The performance analysis of the system is based on Fixed WiMAX, which is a type of WiMAX. The modulation techniques used are BPSK, QPSK and 16-QAM. The objective of this research is to ascertain the performance of the system depending on Bit Error Rate (BER). The simulation and analysis of MC-CDMA system has been done using MATLAB.

Key Words: Orthogonal frequency division multiplexing (OFDM), WiMAX, SUI channel models, fading channels, bit error rate.

1. INTRODUCTION

Mobile and data services have been around for a while now since it started in 1970 and late 1980s respectively, and the demand of interference free communication and high speed data is always increasing. Electronics Communication started with analog domain and then digital domain was adopted to improve the performance of communication system. Analog modulation techniques were replaced by digital modulation techniques as for mobile communication and other related communication that were concerned. The first communication system developed was Advanced Mobile Phone Service (AMPS) which was analog. This was the 1st generation. The growing number of users forced the designers to develop new system and it was called the 2nd generation, which is a digital system. 2nd generation (2G) provided new and better services like Short Message Service (SMS), Time Division Multiple Access (TDMA), and Global System for Mobile System (GSM), IS-90 Code Division Multiple Access (CDMA). The next generation, the 3rd generation (3G) gives more services to its users like faster data rates and video services. 3G services are Universal Mobile Telecommunication System (UMTS) and CDMA2000. But with growing number of users and the requirement of

higher data rates, it has become difficult for communication engineers to find optimum method to satisfy the needs of the users. Now the new technology has been evolved, known as the 4th generation (4G). WiMAX is a 4G technology. One multiple access technique proposed for the 4G wireless communication is Multi Carrier Code Division Multiple Access (MC-CDMA). MC-CDMA is a new wireless communication technology formulated by combining OFDM and CDMA. Therefore it utilizes the advantages of both the techniques simultaneously. MC-CDMA provides higher data rates. The transmitter and receiver for MC-CDMA system consists of both CDMA and OFDM system. The data signal is converted into parallel subcarriers, modulated converted back into single stream and then transmitted. The data signal first goes through the CDMA transmitter and then it is processed in the OFDM transmitter. On the MC-CDMA receiver the signal first gets through the OFDM receiver and then through the CDMA receiver.

1.1 OFDM System

OFDM is a digital Multicarrier Modulation digital transmission technique. It has gained popularity because it has the ability to transmit data at high rates. In OFDM, original data symbols are divided into N sequences and are transmitted over N subcarriers. It is a special form of spectrally efficient technique, which employs densely spaced orthogonal subcarriers and overlapping spectrums. The use of such subcarriers makes OFDM distinguish from conventional FDM (Frequency Division Multiplexing).

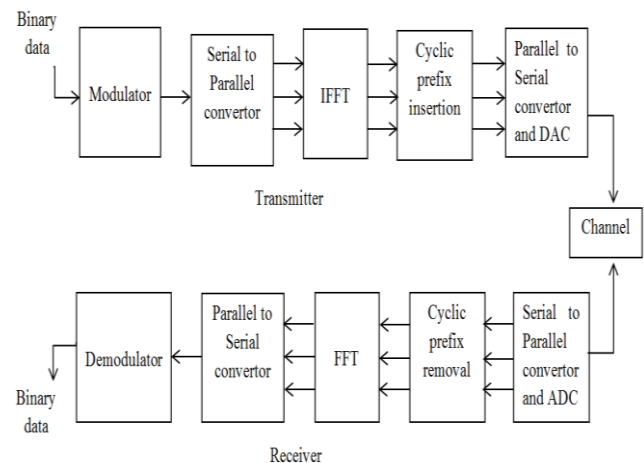

Fig -1: Block diagram of OFDM system

Figure 1 is implicating the working of transmitter and receiver of a basis OFDM system. The transmitter of an OFDM system consist of a modulator, serial to parallel (S/P) convertor, IFFT block, CP (Cyclic Prefix) insertion block and a parallel to serial convertor. The data to be transmitted is modulated using QPSK, QAM etc. and is then converted into parallel form by S/P convertor. This signal consists of OFDM symbols which are short parallel sequences. This generated signal is in frequency domain. The discrete counterpart of Fourier Transform i.e. Inverse Fast Fourier Transform (IFFT) is employed to change the domain to time domain. It also introduces the spacing between the individual signals which makes them orthogonal to each other. A circular extension known as the CP is added at the head of OFDM symbols in order to eliminate both ISI and ICI. To achieve this goal, the CP length must be greater than the delay spread of the multipath channel [13]. This CP is a kind of guard band and it tends to decrease the spectral efficiency of the system because it carries no information. Therefore the selection of CP should be considerate of this complicating factor. After the addition of CP, parallel to serial convertor changes the data into serial form to make it suitable for transmission through channel.

The receiver section of the system performs the reverse operation. Received serial signal is changed to parallel form. The cyclic prefix or the guard time is removed. Then FFT transforms the signal in frequency domain so that it can be used for further processing after getting converted into serial form by parallel to serial convertor. The demodulator then converts the signal back to its original form.

1.2 CDMA

CDMA is a type of spread spectrum technique in which frequency spectrum is spread out. It uses direct sequence spread spectrum technique. It is a multiple access technique which provides accessibility of same network to multiple users. The users are able to access the network same time and can consume the whole frequency spectrum. It uses spreading codes, which is allotted to each user. If N number of users are using the network then N number of distinguish codes will be generated which will be assigned to each user. N users communicate without interference because of different spreading codes.

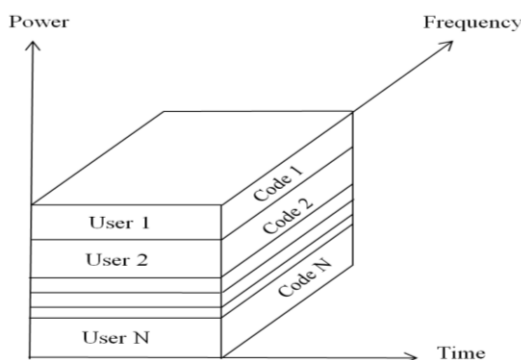

Fig -2: CDMA spectrum representation

The application of distinguish spreading codes helps identifying each user enrolled in the system. The use of spreading code spreads the band spectrum hence making each subscriber's communication secure. In the spread spectrum model, user data signal to be transmitted is spread when a spreading code is applied to it.

Spreading is done at the transmitter when a spread code is multiplied with the user data. At the receiver the required user data is extracted with the help of correlation and this process is called descrambling. The spreading codes are one of the major elements within the whole CDMA system. The codes are combined with the data signal to be transmitted in such a way that the required bandwidth is increased and hence the advantages of spread spectrum are availed.

Spread spectrum is frequency spectrum in which energy generated at a single frequency is spread over a wide band of frequencies. The frequency band for spread spectrum is made much wider than required by the information carried by them. This technology uses wideband, noise like signals which are hard to detect, intercept or demodulate. For converting a data signal into spread spectrum, each and every data bit of the data signal which is to be transmitted, is multiplied by a secret code called chipping code. This chipping code is a spreading code. This process is called spreading. At the receiver, the same chipping code used at the transmitter is used to get the original signal. This process is called despreading. Despreading is accomplished by the use of correlation function. The received spread signal is correlated to a synchronized replica of the spreading code which was used to spread the data signal at the transmitter.

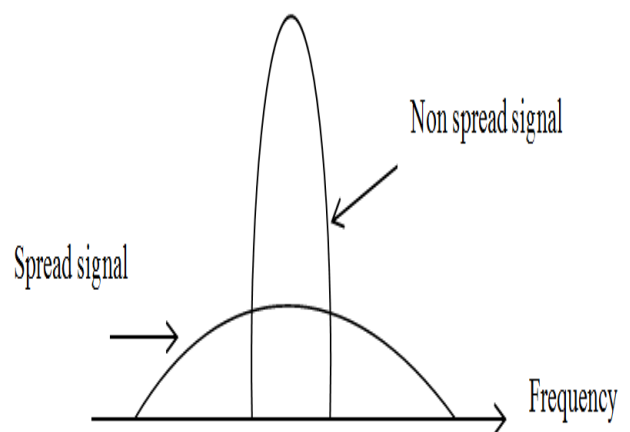

Fig -3: Spread and non-spread signal

The spreading codes are unique and are specific to each user who is making use of the system. These spreading codes enable the different users to gain access of the system. Different codes used in the CDMA system are PN codes, Gold sequence codes, and Walsh Hadamard codes. These codes are described below.

- PN code: PN code is coded sequence of 1s and 0s. It is a type of deterministic code that exhibits the

properties of randomness. Hence PN code makes the signals appear wide band and noise like spectrum. Its outcome can be equated to outcome of tossing a coin with 1 and 0 instead of heads and tails. If current state of PN code is known, the future state of the code can be predicted. A PN sequence generator consists of shift registers 1 to M and a logic circuit, preferably EX-OR. A timing clock regulates the shift registers. A binary sequence is generated by shifting binary data through shift registers. This logical data is then fed back to the first stage. The possible states can be 2^M for M flip flops.

- Gold sequence codes: PN sequence is not able to generate optimum results for auto-correlation hence new series was generated by altering some properties of the PN sequence. So the Gold sequence codes are from PN code's family. Gold sequence codes can be produced by modulo-2 addition (EX-OR) of 2 Maximum Length Sequence (ML). ML is a sequence of length $2^m - 1$, where m is the number of flip flops used for generation of binary sequence. On each tick of clock two sequences are added chip by chip. This code helps generating large numbers of codes.
- Walsh Hadamard code: This code is used for error detection. It is named after Jacques Hadamard. This code has better BER performance than PN and Gold sequences. Walsh codes are used in direct sequence spread spectrum (DSSS) systems like CDMA. Walsh Hadamard code is generated using the Hadamard matrix H. A Hadamard code is obtained by selecting as codewords, the rows of the Hadamard matrix. This matrix is of order n, i.e. (n x n) comprising of 1s and 0s such that each row differs from any other row in exactly N/2 locations. The minimum distance for these codes is N/2 [17]. This matrix can only exist if n is 1, 2 or a multiple of 4. This sequence is orthogonal therefore the cross correlation of two sequences should be zero.

1.3 MC-CDMA

MC-CDMA is a new modulation technique, which came into being by using two techniques together. Those two techniques are OFDM and CDMA. The difference between traditional DS-CDMA and MC-CDMA is that in MC-CDMA frequency spectrum is spread in frequency domain whereas in DS-CDMA spectrum band is spread in time domain. OFDM block of MC-CDMA introduces orthogonality in the signal by applying orthogonal matrix to the user bits. The operation in MC-CDMA is like frequency diversity. Every symbol is modulated on several subcarriers to introduce frequency diversity instead of using only one carrier like in CDMA. Each bit is transmitted simultaneously parallelly on different subcarriers. Each subcarrier has a constant phase offset. The set of frequency offsets forms code to distinguish different users. Each bit is transmitted over N different subcarriers.

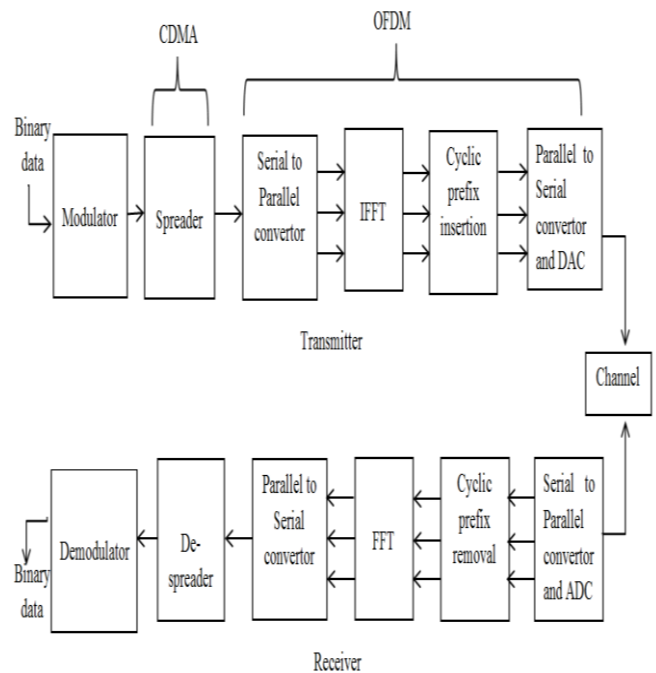

Fig -4: Block diagram of MC-CDMA

The components of a MC-CDMA system consist of the components used in OFDM system and CDMA system. Figure 3, elucidates its working. For MC-CDMA, first CDMA technique is applied and then OFDM technique is deployed. The information signal is first spread, and then it is divided into subcarriers. After which its domain is changed to frequency domain by IFFT, and then cyclic prefix is added so that the system becomes resistant to the effects of ICI (Inter Carrier Interference). After changing it to serial and analog form it is transmitted.

On the receiving end the received modulated signal is changed into parallel and digital form. The CP is removed and its domain is changed back to frequency by FFT. After going through parallel to serial convertor, the signal is now no longer an OFDM signal. This signal is disspread and is then demodulated to get the original information signal.

MC-CDMA technology provides advantages such as high spectral efficiency with secured communications, increased number of users and less complex receiver but it suffers from critical problem which is inherited from OFDM system that is Peak to Average Power Ratio (PAPR).

2. WiMAX

Worldwide Interoperability for Microwave Access or WiMAX is a wireless communication system that can provide long distance broadband wireless access (BWA) with high data transmission rates in a point to multipoint connection and line of sight or non-line of sight environment. It is a 4g wireless technology and comes under Wireless Metropolitan Area Network (WMAN). It also provides greater coverage than the WiFi network. WiMAX is a technology based on

IEEE 802.16 standard which is reserved for WMAN. This standard is designed to operate in the 10-66 GHz spectrum and specifies the physical layer and medium access control layer of the air interface BWA systems. WiMAX can be put to use in a variety of spectrum bands: 2.3GHz, 2.5 GHz, 3.5 GHz and 5.8 GHz, the frequency bands licensed by various government authorities. WiMAX can support both Fixed and Mobile broadband networks and this constitutes its two types: Fixed WiMAX and Mobile WiMAX.

Both Fixed and Mobile WiMAX technologies are based on IEEE 802.16 standard. Fixed WiMAX is used for IEEE 802.16 technology under the name IEEE 802.16-2004. Fixed WiMAX is better known as IEEE 802.16d. It is principally used for providing fixed wire-line services which are the services where subscriber terminals are placed at fixed stations. It provides services which are much the same as the services provided by the fixed line broadband. Fixed WiMAX uses OFDM as its physical layer where FFT size is 256.

Mobile WiMAX is provides broadband wireless approach and facilitates the coordination of mobile and fixed broadband networks through a common wide area broadband radio access technology. It is also known as IEEE 802.16e-2005 and more commonly as IEEE 802.16e. It provides higher data rates and larger coverage areas hence it is known as 4G technology. Orthogonal Frequency Division Multiple Access technology (OFDMA) is used as the physical layer of Mobile WiMAX and the FFT sizes used are 128, 512, 1024, and 2048.

3. FADING CHANNEL AND SUI CHANNEL MODELS

A channel is a physical connection between transmitter and receiver. A channel model is used approximate the way errors are introduced in data stream when it is transmitted over a medium.

A Fading Channel is known as communications channel which has to face different fading phenomenon during signal transmission. In practical scenarios, the radio propagation is affected by the multipath distortion generated by these fading channels. Therefore a model is necessary to predict the effects of fading in order to extenuate its effects. Two types of fading channel models used are:

- Rayleigh fading channel model

This channel model is useful in conditions where the signal can be considered to get dispersed between transmitter and receiver. In this case there is no single path but multiple paths. This model can be used to describe the case of multipath propagation. It is experienced in an environment where there are a large number of reflections. The Rayleigh fading model can be utilized for the analysis of radio signal propagation on the statistical basics. Absence of predominant signal can be significant to obtain the best results for this channel. A line of sight (LOS) signal can be

considered as a predominant signal. Its envelope distribution is identical to that of a noise signal.

- Rician fading channel model

The Rician fading channel model exists where there is one dominant or a stationary signal component, which is usually LOS signal component. Dominant stationary signal component is the one which does not fades, or where a very small fading pervades. In such cases, envelope distribution generated is Rician. In these fading channel model random multipath components reach at different angles are superimposed on the stationary dominant signal. As the power of the dominant signal decrease, a Rician distribution starts depreciating to a Rayleigh distribution. Areas of application where the Rician fading channel criteria can be put into use are microcellular channels, indoor propagation, vehicle to vehicle communication, satellite communication.

SUI is an acronym for Stanford University Interim. These are channels models designed for WiMAX also called IEEE 802.16. SUI is an extension of an early work stimulated by AT&T Wireless. These channel models are mainly for Fixed WiMAX which is IEEE 802.16d standard. These models are proposed for the scenarios where the cell radius is less than 10 km, the antennas used are either omnidirectional antenna or 30 degree directional antenna with base station antenna height of 15 to 40 m and receiver antenna height of 2 to 20 m. The characteristics of a channel considered by these channel models include multipath delay profile, the K factor distribution and the Doppler spectrum. Other factor considered is the antenna gain reduction factor which is the related to the directional antenna. This model defines 6 channel models each representing three terrain types, Doppler Spreads, Delay Spread and LOS conditions.

Table -1: Channel properties considered under SUI channel models

Channel	Terrain Type	Doppler Spread	Delay Spread	LOS
SUI-1	C	Low	Low	High
SUI-2	C	Low	Low	High
SUI-3	B	Low	Low	Low
SUI-4	B	High	Moderate	Low
SUI-5	A	Low	High	Low
SUI-6	A	High	High	Low

These three terrain types can be explained as follows:

- Terrain type A- Hilly terrain with moderate to heavy tree densities, which results in the maximum path loss

- ii. Terrain type B- Hilly environment but rare vegetation, or high vegetation but flat terrain having intermediate path loss conditions
- iii. Terrain type C- Mostly flat terrain with light tree densities corresponding to minimum path loss conditions

These models use three taps. The recognizable factor for each tap is relative delay (with respect to the first path delay), relative power, Rician K factor, and the Maximum Doppler Shift. There are two sets of relative powers specified for each channel model: one for an omnidirectional antenna and another for 30 degree directional antenna. K-factor is provided for each model, one for 90% cell coverage and 75% cell coverage each for omnidirectional antenna and 30 degree directional antenna.

4. IMPLEMENTATION OF MC-CDMA SYSTEM

MC-CDMA new technology aimed at improved performance over multipath links. It is a modulation method using multicarrier transmission, more precisely OFDM and a multiple access technique, CDMA. OFDM allows the system to have higher spectral efficiency and CDMA allows access to more users.

The performance and working of MC-CDMA system depends upon different factors such as the type of channel used, type of equalizer used, spreading used and the use of channel coding.

4.1 MC-CDMA Transmitter

The transmitter of MC-CDMA system consists of a randomizer, channel encoder, interleaver and a modulator along with OFDM and CDMA transmitter.

Randomizer is the block which is responsible for the random arrangement of the input data present on each burst for each allocation. This is done to avoid long sequence of continuous zeros and ones. It is implemented using pseudorandom binary sequence generator which uses a 15 stage shift register.

Although digital communication is less prone to errors yet there is no control over the errors which could occur due to wrong data reception by the receiver. One solution to this problem is to send the data again. But this will just create wastage of resources. Therefore error correcting codes were formulated to reduce the burden on the system. This error correcting coding is called channel coding. Channel coding used in the implementation of this system consists of RS encoding and convolution coding. Reed Solomon encoding is a type of non-binary error correcting code that is specified as RS (n,k), where n is the size of code word generated by RS encoder and k is the size of data input to RS encoder. It can correct up to t errors, where $t = (n-k)/2$, and 2t is the difference between the output symbols of RS encoder and the input symbols. Convolution coding adds patterns of redundancy to data in order to improve Signal to Noise Ratio (SNR) at the receiving end.

Interleaver is used to performs reordering of data that to be transmitted. Since error correcting codes are designed to protect against channel errors that may occur randomly or in a bursty manner, interleavers scramble the time order of source bits [17]. Source bits are the encoded bits. As a result corrective bursts of data are distributed over a large sequence of data to reduce the effect of burst errors. It enhances the error correcting ability of the codes used.

4.2 MC-CDMA Receiver

At the receiver end of this system, along with OFDM receiver and CDMA receiver, consists an equalizer that performs equalization, de-interleaver that arranges the received sequence back into its original form and channel decoder that performs decoding of the de-interleaved data.

Equalization compensates for intersymbol interference (ISI) created by multipath within time dispersive channels. ISI causes bit errors at the receiver and is considered to be a major factor that stands in the way of high speed data transmissions over the wireless channels and disrupts the smooth working of a communication system. Equalization is a technique used to combat intersymbol interference. [17]. It is a process that reverses the distortion incurred by a signal transmitted through a channel in digital communication and helps in reducing ISI. By applying this method, the retrieval of transmitted symbols is possible. A simple linear filter can be used for equalization.

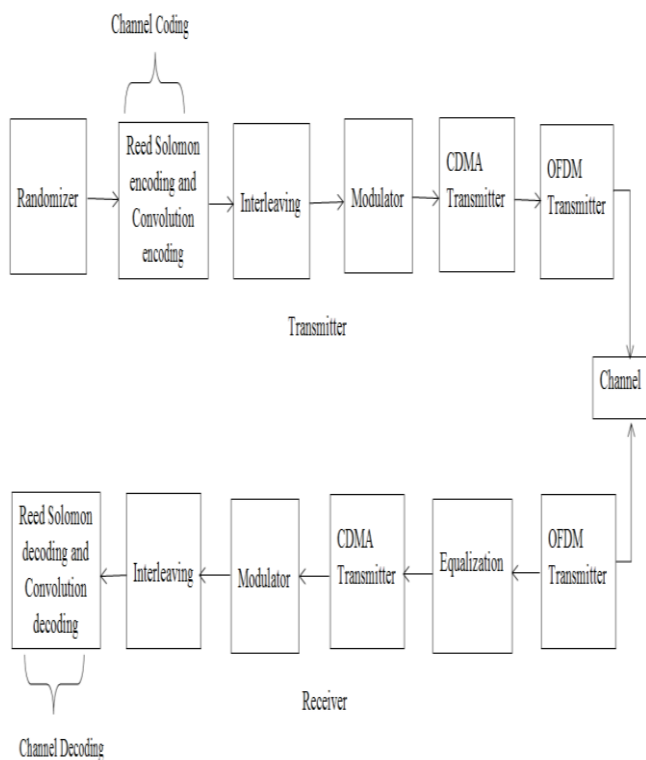

Fig -5: Block Diagram MC-CDMA system implemented

4.4 Parameters used for the implementation of MC-CDMA System

Below are the lists of all the parameters and specification applied for the execution and simulation of MC-CDMA system for Fixed WiMAX.

Table -2: List of parameters used in MC-CDMA system

Parameters	Value
Number of Users	1
Number of Subcarriers and size FFT	256
Modulation techniques	BPSK, QPSK, 16 QAM
Channel Bandwidth	5 MHz
Spreading code	Walsh Hadamard code
Fading Channel Model	Rayleigh, Rician
SUI channel model	SUI- (1-6)

Table -3: Modulation used and channel coding values

Modulation	RS coding	Convolution coding
BPSK	-	CC(1/2)
QPSK	RS(44,36,2)	CC(5/6)
16-QAM	RS(64,48,4)	CC(2/3)

These tables given below are depicting SUI channel model values of three taps used for omnidirectional antenna. These values have been used in the implementation of the MC-CDMA system in this dissertation.

Table -4: Tap for Power of SUI channels

Channel model	Tap 1 (db)	Tap 2 (db)	Tap 3 (db)
SUI-1	0	-15	-20
SUI-2	0	-12	-15
SUI-3	0	-5	-10
SUI-4	0	-4	-8
SUI-5	0	-5	-10
SUI-6	0	-10	-14

Table -5: Tap for 90% K factor of SUI channels

Channel model	Tap 1 (db)	Tap 2 (db)	Tap 3 (db)
SUI-1	4	0	0
SUI-2	2	0	0
SUI-3	1	0	1
SUI-4	0	0	0
SUI-5	0	0	0
SUI-6	0	0	0

4.3 Performance matrices

Bit Error Rate (BER): BER is defined as the number of error bits divided by the total number of transmitted bits during a specific period. There are errors bits occurring within the received bits independent of rate of transmission. By using MATLAB the BER is evaluated. The value of BER depicts the performance level of the system.

Signal to Noise Ratio (SNR): SNR is the ratio of signal power to the noise power, expressed in decibels. It compares the level of desired signal to the level of background noise. It also referred to as the ratio of useful information to false or irrelevant data in a conversation or exchange. Mathematically, SNR is represented as

$$SNR_{db} = 10 \log_{10} (P_{signal}/P_{noise}) \dots\dots\dots(i)$$

5. RESULTS AND ANALYSIS

The results and analysis of the implementation of MC-CDMA system illustrated above are presented here. Results of implementation of MC-CDMA with and without equalization are exhibited below. The performance analysis shows the BER versus Eb/No.

5.1 Graphical results obtained using BPSK Modulation

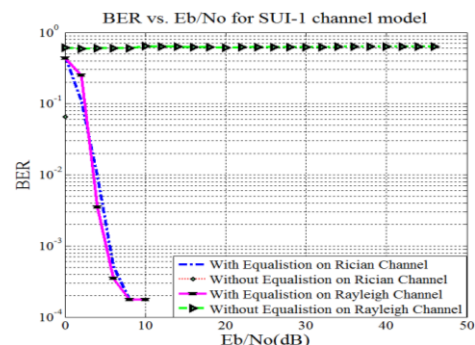

Chart -1: BER performance for Sui-1 model

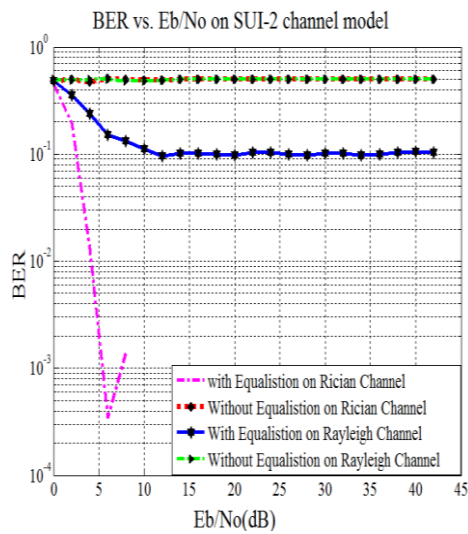

Chart -2: BER performance for Sui-2 model

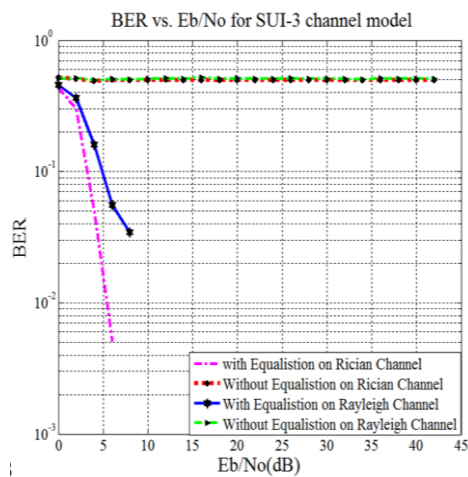

Chart -3: BER performance for Sui-3 model

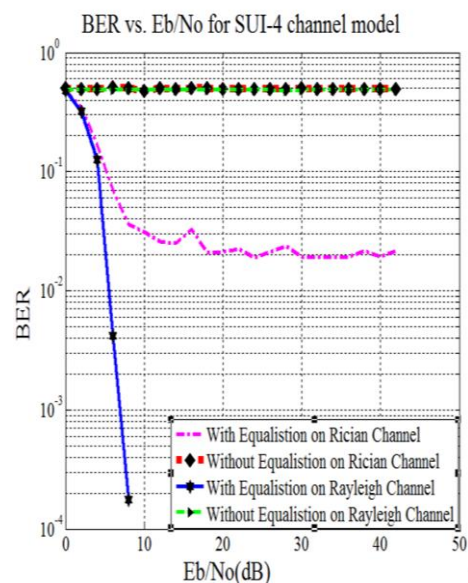

Chart -4: BER performance for Sui-4 model

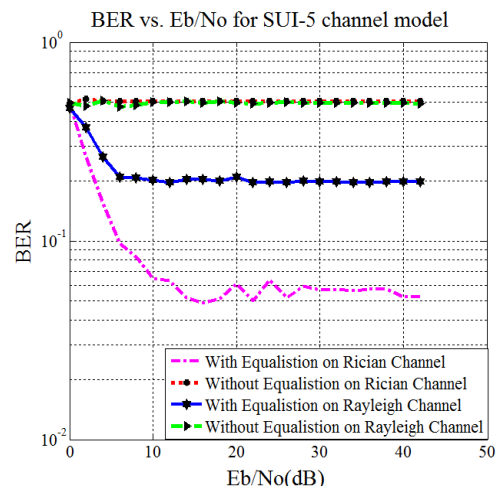

Chart -5: BER performance for Sui-5 model

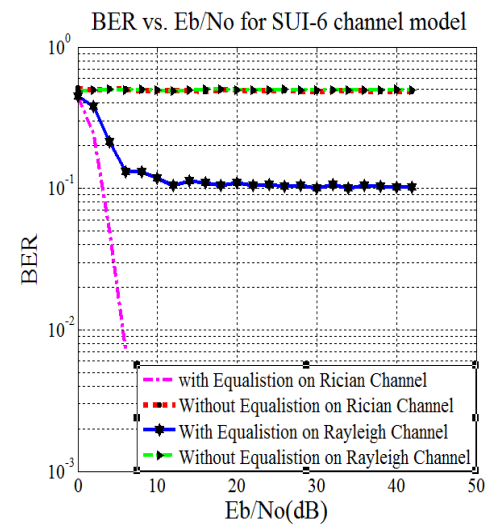

Chart -6: BER performance for Sui-6 model

Table -6: BER values using BPSK modulation

SUI channel	BER values			
	Rician fading channel		Rayleigh fading channel	
	With Equalization	Without Equalization	With Equalization	Without Equalization
SUI-1	0.0247	0.0397	0.0206	0.2025
SUI-2	0.0202	0.5001	0.0779	0.4999
SUI-3	0.0557	0.4997	0.0511	0.5319
SUI-4	0.0679	0.4942	0.0422	0.4999
SUI-5	0.0632	0.5114	0.0507	0.4890
SUI-6	0.0329	0.5001	0.0341	0.4883

These above plots and the table show that BER performance for MC-CDMA improves when equalization is used and best

performance is achieved for Rician fading channel when SUI-2 model is employed. The Eb/No value obtained is 23 and SNR value is 16.9794 for all the channel models.

5.2 Graphical results obtained using QPSK Modulation

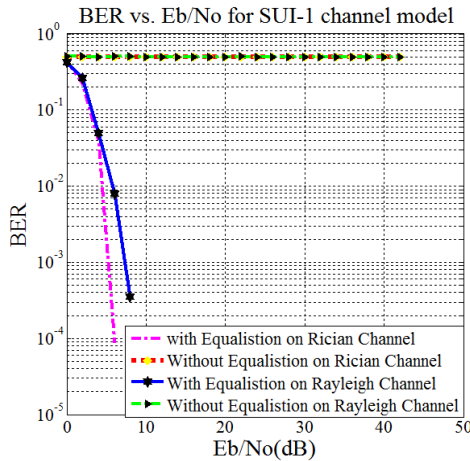

Chart -7: BER performance for Sui-1 model

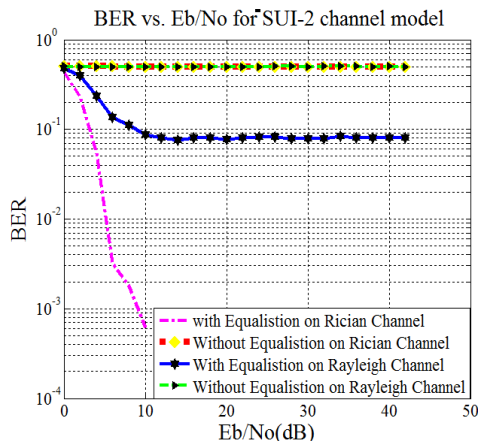

Chart -8: BER performance for Sui-2 model

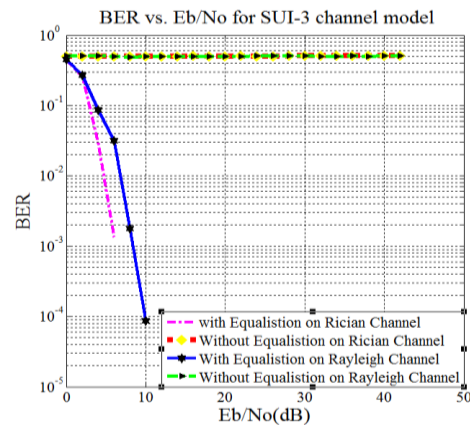

Chart -9: BER performance for Sui-3 model

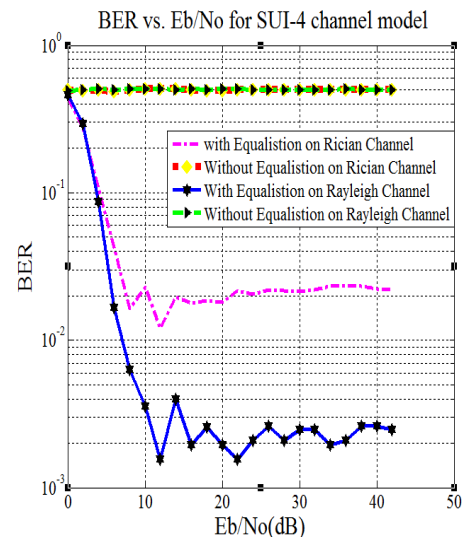

Chart -10: BER performance for Sui-4 model

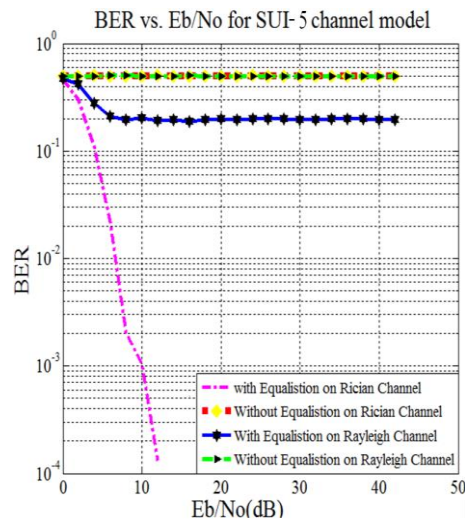

Chart -11: BER performance for Sui-5 model

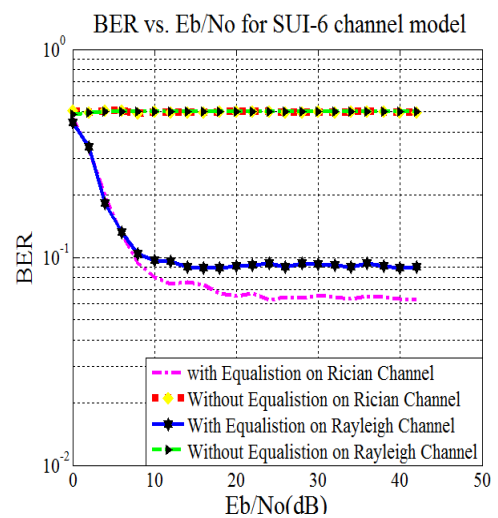

Chart -12: BER performance for Sui-6 model

Table -7: BER values using QPSK modulation

SUI channel	BER values			
	Rician fading channel		Rayleigh fading channel	
	With Equalization	Without Equalization	With Equalization	Without Equalization
SUI-1	0.0318	0.4997	0.0331	0.5004
SUI-2	0.0397	0.4999	0.4160	0.5075
SUI-3	0.0348	0.4988	0.0612	0.5044
SUI-4	0.0274	0.4890	0.0304	0.4953
SUI-5	0.0332	0.4995	0.0461	0.4904
SUI-6	0.0414	0.4958	0.0287	0.5004

The above plots and the table depicts that the best performance is achieved by Rician fading channel when SUI-4 model is employed. The Eb/No value obtained is 21 for all the channel modes and SNR value is 17.9897.

5.3 Graphical results obtained using 16-QAM Modulation

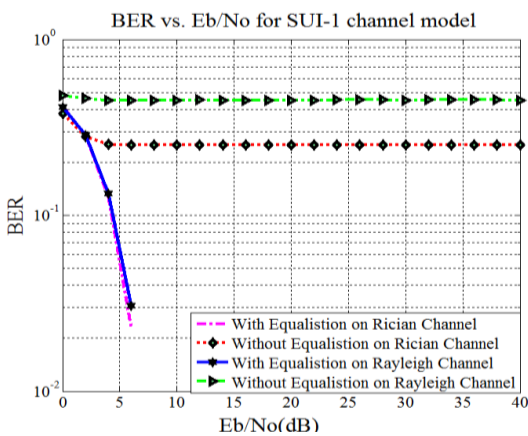

Chart -13: BER performance for Sui-1 model

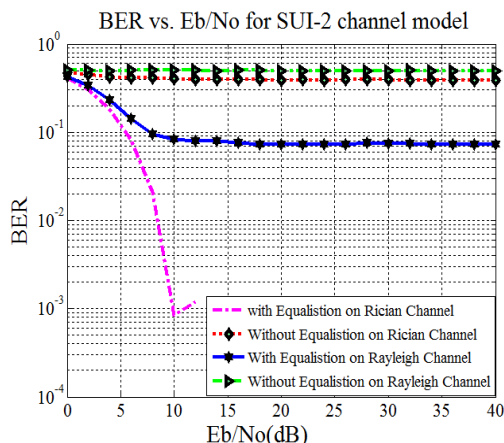

Chart -14: BER performance for Sui-2 model

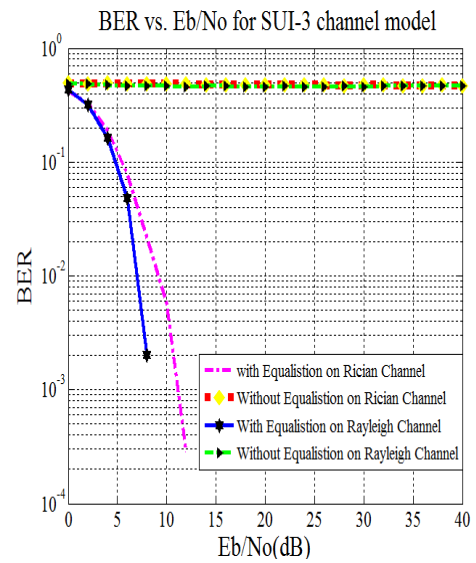

Chart -15: BER performance for Sui-3 model

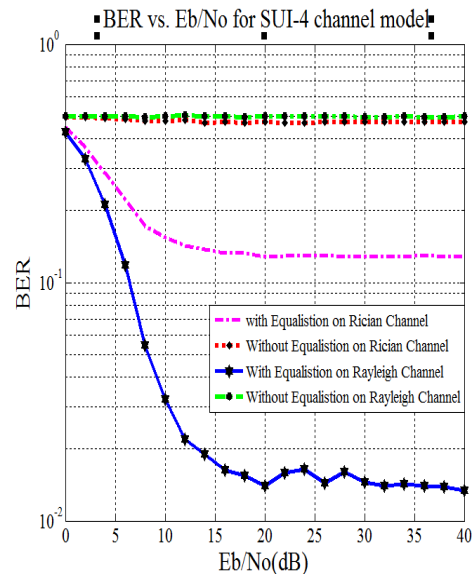

Chart -16: BER performance for Sui-4 model

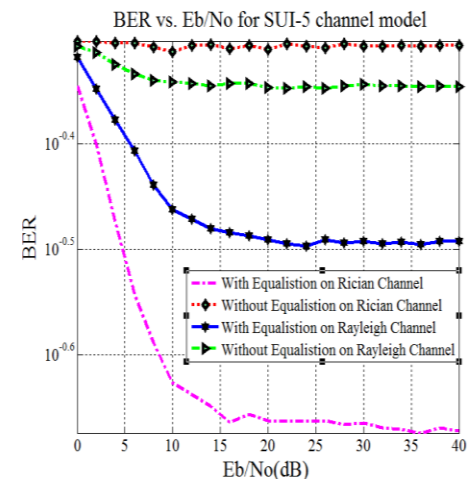

Chart -17: BER performance for Sui-5 model

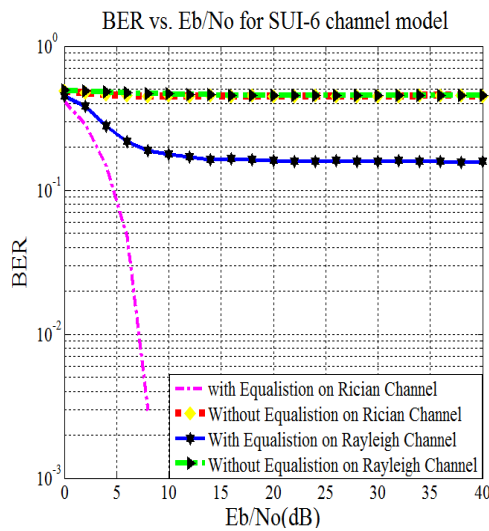

Chart -18: BER performance for Sui-6 model

Table -8: BER values using 16-QAM modulation

SUI channel	BER values			
	Rician fading channel		Rayleigh fading channel	
	With Equalization	Without Equalization	With Equalization	Without Equalization
SUI-1	0.0423	0.2583	0.0409	0.2955
SUI-2	0.0423	0.5077	0.2107	0.5015
SUI-3	0.0471	0.428	0.0437	0.4989
SUI-4	0.1209	0.4990	0.0436	0.4724
SUI-5	0.2187	0.4981	0.2030	0.5003
SUI-6	0.0409	0.5015	0.0436	0.4973

These above plots and the table show that BER performance for MC-CDMA improves when equalization is used and best performance is achieved using Rician fading channel parameters when SUI-4 model is employed. The Eb/No value and SNR value obtained was 21 for all the channel models.

6. CONCLUSION

MC-CDMA system for Fixed WiMAX parameters was analyzed with BPSK, QPSK and 16-QAM modulation schemes. Considering BER values the best performance was generated by 16-QAM modulation when Rician channel model with SUI-4 parameters was used. As for the SNR

values were considered, again 16-QAM was able to generate the best result among the three modulations when used for MC-CDMA system.

REFERENCES

- [1] B.Sarala, D.S.Venkateswarulu, B.N.Bhandari, "Overview of MC CDMA PAPR Reduction Techniques", International Journal of Distributed and Parallel Systems (IJDPS), vol.3, No.2, March 2012, pp. 193-206.
- [2] B.vinodh kumar, A.Arul, M.Christopher, S.Arun kaviarasu, "Analysis and Design of MC-CDMA Based Mobile WIMAX for Different Modulation", International Journal of Advances in Electrical and Electronics Engineering, vol.2, Number 3, pp.338-342.
- [3] Javad Akbari Torkestanian, Mohammad Reza Meybodi, "An efficient cluster-based CDMA/TDMA scheme for wireless mobile ad-hoc networks: A learning automata approach", Journal of Network and Computer Applications, 27 January 2010, pp. 1-14.
- [4] Nilesh Chide, Shreyas Deshmukh, Prof. P.B. Borole, "Implementation of OFDM System using IFFT and FFT", International Journal of Engineering Research and Applications, ISSN: 2248-9622, Vol. 3, Issue 1, January 2013, pp.2009-2014.
- [5] B.vinodh Kumar, Arulpugazhendhi.M, A.Arul," Performance Analysis of MC-CDMA Based Fixed WiMAX Technology By RS Encoder For Different Modulation", Int. Journal of Engineering Research and Applications, ISSN : 2248-9622, vol. 3, Issue, Sep-Oct 2013, pp.1423-1425.
- [6] Harish Sharma, Yogesh Bansal, " Analytical Evaluation of Fixed and Mobile WiMAX System Based on OFDM and MC-CDMA Systems", International Journal Of Research Review In Engineering Science & Technology, ISSN 2278-6643 vol. 4, Issue 1, April 2015, pp. 268-278
- [7] Mojtaba Seyedzadegan, Mohamed Othman, " IEEE 802.16: WiMAX Overview, WiMAX Architecture", International Journal of Computer Theory and Engineering, vol. 5, no. 5, October 2013, pp. 784-787
- [8] A. Bouacha , F. T. Bendimerad , "Performance Study of the MC-CDMA as Physical Layer for Mobile WiMAX Technology", International Journal of Computer Networking, Wireless and Mobile Communications , ISSN 2250-1568, vol. 3, Issue 2, June 2013, pp. 47-52
- [9] Anjali Koranga, Geeta Joshi, "Comparative Study of OFDM & MC-CDMA in WiMAX System", IOSR Journal of Electronics and Communication Engineering, e-ISSN: 2278-2834, p- ISSN: 2278-8735. vol. 9, Issue 1, Ver. IV January 2014, pp. 64-68
- [10] B U Rindhe, D C Shah, S K Narayankhedkar, "OFDM and MC-CDMA for 4G Networks", 2nd International Conference and workshop on Emerging Trends in Technology, 2011, pp. 30-37
- [11] Abdul Hashib Siddique, A K M Arifuzzman and Mohammed Tarique, "Performance study of IEEE 802.16d under Stanford University Interim (SUI) Channel", International Journal of Computer Networks & Communications (IJCNC), vol.5, no.2, March 2013, pp. 137-152
- [12] Er. Vipin Mittal & Prof. S.R. Mittal, "A Cyclic Prefix OFDM System with BPSK Modulation", Global Journal of Researches in Engineering Electrical and Electronics Engineering, Online ISSN: 2249-4596, vol. 12 ,Issue 7 ,Version 1.0 , July 2012, pp. 43-48

- [13] Amar Al-Jzari and Kostanic Iviva, "Cyclic Prefix Length Determination for Orthogonal Frequency Division Multiplexing System over Different Wireless Channel Models Based on the Maximum Excess Delay Spread", American Journal of Engineering and Applied Sciences, 2015, pp. 82-93
- [14] Bhupendra Kumar, Kuldeep Sharma, "Design and Analysis of IEEE 802.16 WiMAX System using Simulink Design and Analysis of IEEE 802.16", International Journal of Research Review in Engineering Science & Technology, (ISSN 2278-6643), vol.4, issue-3, November 2015, pp. 48-51
- [15] Amandeep Singh , Mandeep kaur, "Design and Implementation of Reed Solomon Encoder on FPGA", World Academy of Science, engineering and Technology, International Journal of Computer, Electrica, Automation, Control and Information Engineering, vol. 7,no.9, 2013, pp.1248-1250
- [16] Lathi B.P., Ding Zhi, Modern Digital and Analog Communication Systems, International Fourth Edition
- [17] Rappaport Theodore S. , Wireless Communications: Principle and Practice (2nd Edition)