

Modeling and analysis of knuckle joint used in tractor

Shankar Majhi¹ , Shaheen Beg Mughal²

¹Research Scholar, Department of Mechanical Engineering, ITM University Gwalior, India

²Assistant Professor, Department of Mechanical Engineering, ITM University Gwalior, India

Abstract - Tractor and trailer is a very useful component in agriculture field and transportation the goods in rural and urban area. A knuckle joint which is used to connect the tractor and trailer .It consist of eye forks and pin .The effective design of the component which is attached to the trailer and tractor .When the vehicle is motion the forces is acting on the joint is tensile and it's opposite it is compressive. In the knuckle pin stresses are developed during its operation. Force acting on the fork and pin is calculated by the theoretical study and analytical method. Subjected to high stresses in pin going to be study by using catia V5 and finite element method to be used in analysis.

Key Words: knuckle joint, F.E.A, catia V5, ANSYS software

1.INTRODUCTION

Knuckle joint is a joint which is used to connect two rods under the tensile load. It is a type of hinged joint. However, if the joint is instruct, it may backing a compressive load. This joint can be easily connect and disconnect for adjustment or repairing. The example of knuckle joints are: tension link in bridge structure , tie rod joint of roof truss , link of roller chain , jib crane and railway wagon. This joint permitted limited angular movement between roods about its axis of the pin.

1.1 COMPONENTS OF KNUCKLE JOINT

A knuckle joint can be following these four components

- 2) Single eye end
- 3) Double eye end
- 4) Knuckle pin
- 5) Collar pin
- 6) Taper pin / Split pin

1.2 FAILURE OF KNUCKLE JOINT

A knuckle joint can be failed on the following three modes are:

- 1) Shear failure of pin (single shear)
- 2) Crushing of pin against rod
- 3) Tensile failure of flat end bar

2. LITRATURE REVIEW:

Dharpure and mate: They are working in the study and analysis of the failure condition in knuckle joint which is used in railway couples overdue to shearing as the part of the knuckle pin that a pin is convenient for working of knuckle and there are no loading case is obtained over it however due to the manufacture of the knuckle and their cause of failure of knuckle is initiated in their paper. They using finite element method for describe the possible failure and elasticity required in the material. Such as shear failure of pin , crushing failure of pin ,crushing failure of pin in coupler , bending failure of pin . After finding the various possible failure and elasticity of the material. Their analysis is done in the using of catia software and they concluded that due to better flexible material is used for pin is plastic material i.e. steel. That material also prohibited to rust and corrosion and there is low coefficient of friction between the knuckle , pin and coupler body [1].



fig. failure of knuckle pin

Rangari et. Al.: They analyzed the knuckle joint used in Mahindra 575 DL . their views on knuckle joint is failure in various condition like single eye , double eye or fork pin .He hinds the mainly failure in the knuckle pin which is bending during the carry heavy loads. So they have to change the pin again and again .In engineering field we have to reduce the cause of failure of pin to using various methodology. they used to theoretical and F.E.A to determine the cause of failure also they using the different material for designing the knuckle pin like grey cast iron, steel and titanium at equal loading condition they found that there is equivalent stress , shear stress and total deformation is maximum stresses on same loading condition[2].

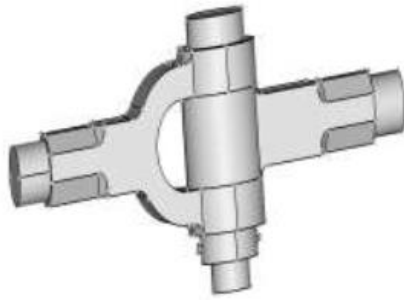

Fig: design of knuckle joint (3D)

Bhasha and Vanka :In this paper he had been using the finite element method to perform the modeling and analysis of the knuckle joint. For 3D model is modeling in catia software and analysis is done on ANSIS soft ware. He applied the F.E.A method for stainless steel , grey cast iron , and Teflon material.after that they check the various failure modes in different loading condition and they designed the knuckle for 50KN axial load in theoretical calculation and stress produced in Teflon material is very close to stainless steel and grey cast iron [3].

Patil et. Al.: In this paper they calculate the knuckle joint stress with using the analytical method. In these people study about the modeling and analysis of a knuckle joint using F.E.M. he also define the failure modes of knuckle joint due to various stresses are develop for reducing the stress they using the F.E.M in their research paper. first of all they draw the geometric model in catia V5 and after that analytical simulation is to be proceed in the several material choose for manufacturing of knuckle joint such cast iron . they finalized the structural steel to be used for modeling and analysis. In catia V5 concluded that generating the meshes and given the second order tetrahedron meshing total element contend and total nodes contained , after completing the meshing they simulated in the ANSYS software and we obtained stress are very less than the yield stress of steel [4].

Shinde and kalita : In this paper said that about the knuckle joint which is used in the tractor trollry. He said that tractor acceleration is main reason for force acting on the knuckle joint, they consider the newton second law for case study their first step has to be modeling and analyzing machine component and draw on the solid model.They seen that accuracy of solid model is directly depend on the obtained result from ANSYS. It is based on the actually dimension are calculated for a traile [5].

Herakal et. Al.: They study the knuckle joint using the finite element method .The knuckle joint is modeled in catia V5 .he study about the geometric model and draw it and after that is meshing in ANSYS and the result says that under loading condition igher stress developed in the fork and the less stress developed in eye and applied stress in the fork is more

higher than allowable stress then it is not able to design the component as the safe point of view [6].

3. CONCLUSIONS

After studying the knuckle joint which is used in tractor and trolley , modeling and analysis on knuckle pin as following: According to our theoretical study , calculation and F.E.A have to around similar results on 50 mm diameter at 60 KN. We also find the when increase the stress on pin can be bending but we increase the pin diameter. it will wear maximum stress on that force.

REFERENCES

- [1] Dharpure S. Ravindra and Mate M.D. Study and analysis of pin of knuckle joint in train, journal of emerging technologies and innovative research (JETIR) ,volume 1 issue 3, page no-167-173.
- [2] Datey swati, Rangari A. Amit, Dongre A. Adarsh, Paraskar A. Kunal, Lidbe V. Sanket ,year- 2017, Analysis of Knuckle Joint used in Mahindra 575DL , international of advance research and innovative ideas in education (IJARIE) ,volume- 3 Issue- 2 , page no- 1527-1538.
- [3] Bhasna john Shaik and Vanka Shankar Hari ,Year-2015 , Modeling and Analysis of Knuckle Joint , international journal & magazine of engineering, technology, management and research (IJMETMR), volume 2 issue- 11 page no- 292-298.
- [4] Patil Nilesha , Sable M Sayali , Munde Kashinath ,Year-2016 ,Static Structure Analysis of Knuckle Joint , international journal of advance technology in engineering and science (IJATES) ,volume- 4 issue- 12, page no- 119-125.
- [5] Shinde Dinesh and Kalita Kanak , year-2015 , Fe of Kunckle Joint Pin Used In Tractor Trailer , ARPN Journal of Engineering and Applied Sciences, volume- 10 issue-5, Page no- 2227-2232.
- [6] Herakal B Sangamesh , Avadhani Ranganath and Goud Chakradhar S, Year- 2016 ,Structural Static Analysis Of Knucle Joint , International Journal of Engineering Research and General Science , volume- 4 issue- 2 ,page no- 176-182.