

# Comparative Study of R.C.C & Structural Steel -Concrete Composite Frame for Linear and Non-Linear Analysis

MOHD AMIR KHAN

*M.Tech (Structural & Foundation Engineering)*

*Department of Civil Engineering Al FALAH UNIVERSITY, Faridabad INDIA*

\*\*\*

**Abstract** –Structural Steel-Concrete composite structures are nowadays very popular owing to their advantages over conventional Concrete and Steel constructions. Concrete structures are bulky and impart more seismic weight and more deflection as compare to Composite Construction combines the better properties of both steel and concrete along with lesser cost, speedy construction, fire protection etc. Hence the aim of the present study is to compare seismic performance of RCC, Steel and Composite building frame situated in earthquake zone IV. All frames are designed for same gravity loadings. The slab is used in concrete and deck slab in composite building. Beam and column sections are made of Either RCC and Structural Steel-concrete composite sections. Equivalent static method and Response Spectrum method are used for seismic analysis and Non-linear static pushover analysis. Software is used and results are compared.

**Key Words:** Linear Static and Dynamic, Non-Linear static pushover analysis and performance based analysis, ETABS

## 1. INTRODUCTION

Structural Steel-concrete composite systems have become quite popular in recent times because of their advantages against conventional construction. Composite construction combines the better properties of the both i.e. concrete and steel and results in speedy construction. In the present work included Comparative study of R.C.C. Recent trends in construction industry is to use of steel, reinforced concrete and structural steel-concrete composite member which are functioning together and termed as composite, mixed or hybrid systems. Such systems make use of each type of member in most efficient manner to maximize the structural and economic benefit. An additional benefit provided by composite frame is derived from their excellent fire-resistant properties. Over the past twenty years the composite RCS moment frame systems have been used in the US and Japan. Extensive research is currently underway to better understand the behaviour of such frames. Much of this research aims at experimentally investigating the characteristics of joints between steel and reinforced concrete members and understanding the behaviour of mixed assemblies.

### 1.1 COMPOSITE DECK SLAB

Composite floor system consists of steel beams, metal decking and concrete. They are combined in a very efficient way so that the best properties of each material can be used to optimize construction techniques. The most common arrangement found in composite floor systems is a rolled or built-up steel beam connected to a formed steel deck and concrete slab. The metal deck typically spans unsupported between steel members, while also providing a working platform for concreting work. The composite floor system produces a rigid horizontal diaphragm providing stability to building.

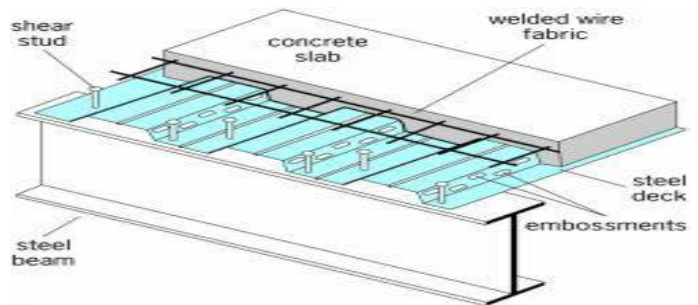

Fig.no.1 DECK SLAB

### 1.2 COMPOSITE BEAM AND COLUMN

A structural steel-concrete composite column is a compression member, comprising either of a concrete encased hot rolled steel section or a concrete filled hollow section of hot rolled steel. It is generally used as a load bearing member in a composite framed structure. Composite members are mainly subjected to compression and bending.

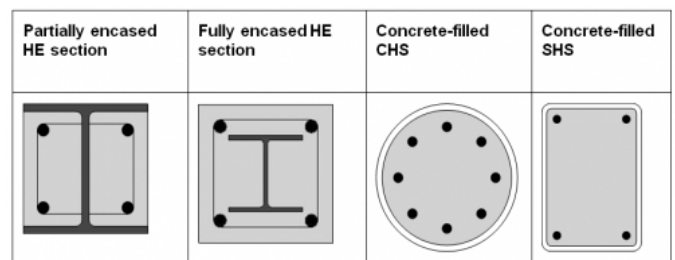

Fig.no.2 COMPOSITE COLUMN AND BEAM

### 1.3 ACTION OF COMPOSITE BEAM

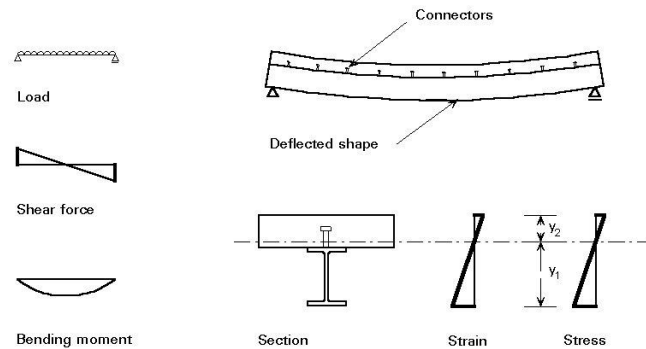

Figure 4 Composite beam-stage 1

Fig.no.3

### 1.4. ACTION OF COMPOSITE COLUMN

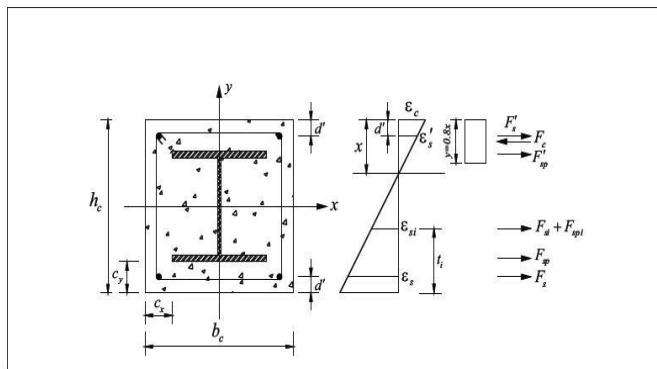

Fig.no.4

### 1.5. SHEAR CONNECTOR

The total shear force at the interface between concrete slab and steel beam is approximately eight times the total load carried by the beam. Therefore, mechanical shear connectors are required at the steel-concrete interface. These connectors are designed to (a) transmit longitudinal shear along the interface, and (b) Prevent separation of steel beam and concrete slab at the interface. Commonly used types of shear connectors as per IS: 11384-1985. There are three main types of shear connectors, rigid shear connectors, flexible shear connectors and anchorage shear connectors.

## 2. OBJECTIVES

1. Brief description to various components of structural steel-concrete composite framing system for buildings.
2. To provide analysis of R.C.C and Structural Steel-Concrete Composite frame.
3. To perform Linear Analysis and Non-Linear Analysis.

4. To study the performance of R.C.C and structural steel-concrete composite section w.r.t. different parameters such as story drift, story displacement, base shear, shear force etc.
5. To study the hinge formation during the performance of composite frame to verify strong column weak beam.
6. To determine the effect of earthquake on various parameters like fundamental, time period, storey drifts, lateral joint displacements, bending moments and shear force in beam and columns.
7. To study the hinge formation during the performance of composite frame to verify strong column weak beam behaviour of the members.
8. To determine the performance point of R.C.C and structural steel-concrete composite frame by capacity spectrum.

## 3. METHODOLOGY

### 3.1. LINEAR STATIC ANALYSIS

This method is based on the assumption that whole of the seismic mass of the structure vibrates with a single time period. The structure is assumed to be in its fundamental mode of vibration. But this method provides satisfactory results only when the structure is low rise and there is no significant twisting on ground movement. As per the IS 1893: 2002, Total design seismic base shear is found by the multiplication of seismic weight of the building and the design horizontal acceleration spectrum value. This force is distributed horizontally in the proportion of mass and it should act at the vertical center of mass of the structure.

### 3.1.2. DYNAMIC ANALYSIS

Dynamic analysis is performed after the static analysis is completed. Therefore the response-spectrum scale factor is  $I g / R$ , where  $g$  is acceleration due to gravity ( $386.4 \text{ in/sec}^2$  for kip-in and  $9.81 \text{ m/sec}^2$  for KN-m). After analysis, users should review the base shear due to all modes, reported in the Response Spectrum Base Reaction Table. If the dynamic base shear reported is more than 80% of the static base shear, no further action is required. However, if dynamic base shear is less than 80% of the static base shear, then the scale factor should be adjusted such that the response-spectrum base shear matches 80% of the static base shear. In this case, the new scale factor would be  $(I g / R) * (0.80 * \text{static base shear} / \text{response-spectrum base shear})$ . Analysis should then be rerun with this scale factor specified in the response-spectrum.

### 3.2 NON-LINEAR STATIC ANALYSIS

Non-linear static analysis is improvement over linear static or dynamic analysis in the sense that it allows inelastic behavior of structure. The method is simple to implemented and provide information on strength, deformation and ductility of the structure as well as distribution of demands.

This permits the identification of critical member that are like to reach limits states during the earthquake, to which attention should be paid during the design and detailing process. But this method is based on many assumptions which neglected the vibration of the loading patterns, the influence of higher modes of vibration and the effect of resonance. In spite of deficiencies this method known as **pushover analysis**. It is the method of analysis by applying specified pattern of direct lateral loads on the structure, starting from zero to a value corresponding to a specific displacement level, and identifying the possible weak points and failure patterns of a structure. The performance of the structure is evaluated and using the status of hinges at target displacement or performance point corresponding to specified earthquake level (the given response spectrum). The performance is satisfactory if the demand is less than capacity at all hinge locations.

### 3.2.1. CAPACITY SPECTRUM METHOD

Provide graphical representation of expected seismic performance of the structure intersecting the structure capacity spectrum with response spectrum (Demand spectrum) of the earthquake. The intersection point is called as performance point and displacement coordinate **dp** of the performance point is the estimated displacement demand on the structure for the specified level of hazard.

## Capacity Spectrum Method - details in ATC-40

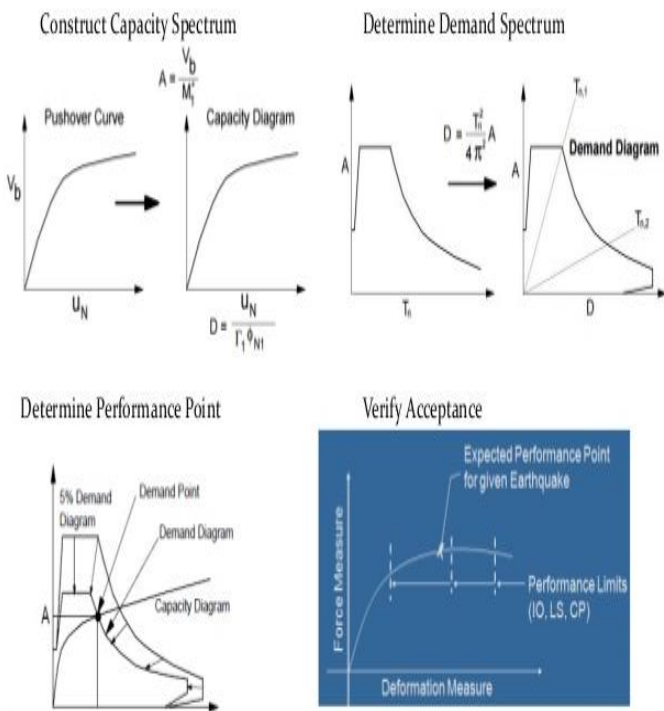

Fig.no.5

## 4. MODEL CONFIGURATION

Table.no.1

	R.C.C BUILDING	COMPOSITE BUILDING
HEIGHT	33.5 m	33.5 m
AREA	240 sqm.	240 sqm.
Each Story height	3m	3m
COLUMN	0.4m*0.5m (1st to 5 <sup>th</sup> floor) 0.3m*0.4m ( 6 <sup>th</sup> to 11 <sup>th</sup> floor)	0.4m*0.5m (1 <sup>st</sup> floor ) and 0.3*0.4m (Encased ISHB 250) (2 <sup>nd</sup> to 11 <sup>th</sup> floor)
BEAM	300mm*350mm	250*350mm ISHB 250
SLAB	125mm	125mm
GRADE OF CONCRETE	25M (SLAB)	25M(SLAB)
GRADE OF CONCRETE	25M (BEAM)	25M (BEAM)
GRADE OF CONCRETE	30M(COLUMN)	30M(COLUMN)
GRADE OF STEEL	FE415 (Rebar)	Fe 250(BEAM) and Fe 345(COLUMN)
ZONE	IV	IV
REGION	DELHI	DELHI
LIVE LOAD	3KN/sqm	3KN/sqm

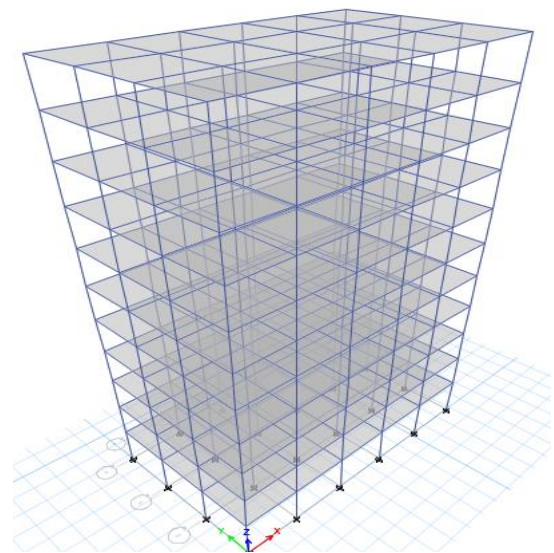
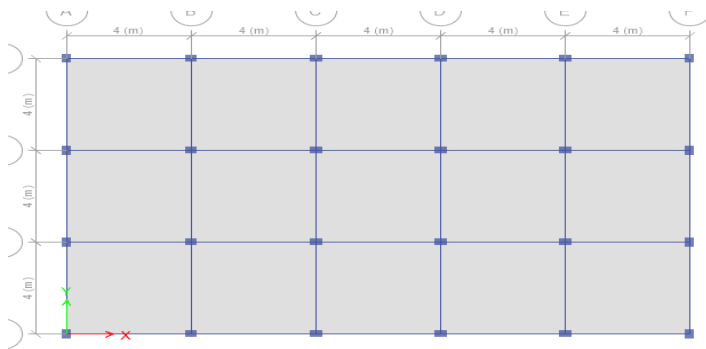

Fig.no.6 PLAN and 3D VIEW



**4.1. STATIC ANALYSIS OF BUILDINGS USING IS 1893 (PART 1)-2002**

**Design Seismic Base Shear-**

The total design lateral force or design seismic base shear (VB) along any principal Direction of the building shall be determined by the following expression

$$VB = Ah \times W$$

Where

Ah = Design horizontal seismic coefficient.  
W = Seismic weight of the building

**Seismic Weight of Building-**

The seismic weight of each floor is its full dead load plus appropriate amount of imposed load as specified. While computing the seismic weight of each floor, the weight of columns and walls in any story shall be equally distributed to the floors above and below the story. The seismic weight of the whole building is the sum of the seismic weights of all the floors. Any weight supported in between the story shall be distributed to the floors above and below in inverse proportion to its distance from the floors.

**Fundamental Natural Time Period-**

The fundamental natural time period (Ta) calculates from the expression

$$Ta = 0.075h^{0.75} \quad \text{for RC frame building}$$

$$Ta = 0.085h^{0.75} \quad \text{for steel frame building}$$

If there is brick filling, then the fundamental natural period of vibration, may be taken as

$$Ta = \frac{0.09h}{\sqrt{d}}$$

**Distribution of Design Force-** The design Base Shear, VB computed above shall be distributed along the height of the building as per the following expression

$$Qi = \frac{Vb \cdot Wi \cdot hi^2}{\sum Wj \cdot hj^2}$$

**Seismic Loads** As per IS-1893-2002, seismic analysis of the structure is performed. The design horizontal seismic

coefficient, Ah for the structure has been computed using the following:

1. Zone factor, Z = 0.24 (Zone IV)
2. Importance factor I = 1.0
3. Response Reduction factor, R = 5
4. Soil type = Medium Soil
5. Damping Coefficient = 0.05
- 6 Time period =  $0.075 H^{0.75} = 0.75 * 35.5^{0.75} = 2.08 \text{ sec}$

**4.2 WIND LOAD CALCULATION**

Basic wind speed = Vb = 47m/s

Structure class B

Terrain category 2

Risk coefficient = 1

Topography = 1

Design wind speed Vz = Vb \* k1 \* k2 \* k3

Rectangular building

Terrain Category I

Plan length = 20 m

Plan width = 12 m

Height of building = 35.5 m

Face width = 20 m

Face depth = 35.5 m

Interval = 4 m

k1 = 1

k2 (at 33.5 m) = 1.00

k3 = 1.00

Vb = 47 m/s

Vz = Vb x k1 x k2 x k3 = 47 m/s

Wind pressure =  $P = 0.6 * (Vz)^2 = 0.6 * (47)^2 = 1.325 \text{ KN/m}^2$

**5. RESULTS**

**5.1 BASE SHEAR**

	COMPOSITE	RCC
Dead Load	15164. KN	16997.408 KN
EQ-x	489.18 KN	580.9187 KN
EQ-y	489.18 KN	580.918 KN
RS-x	489.18 KN	552.177KN
RS-y	489.18 KN	549.458KN

Table.no.2

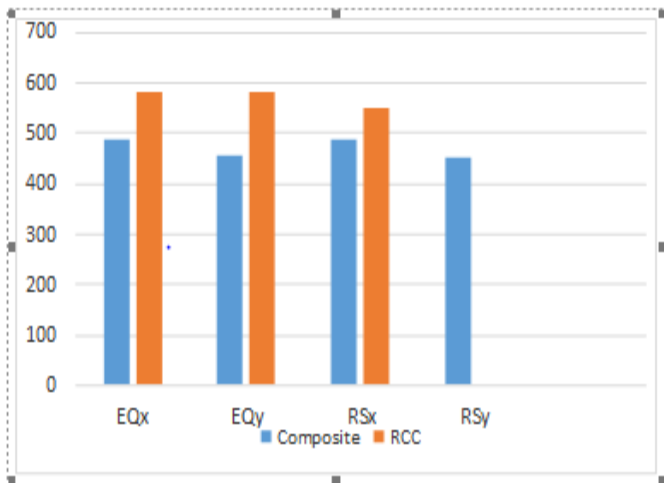

Chart.no.1 BASE SHEAR

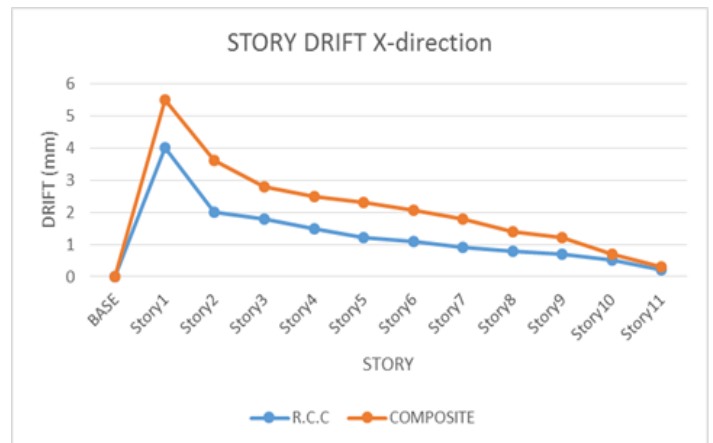
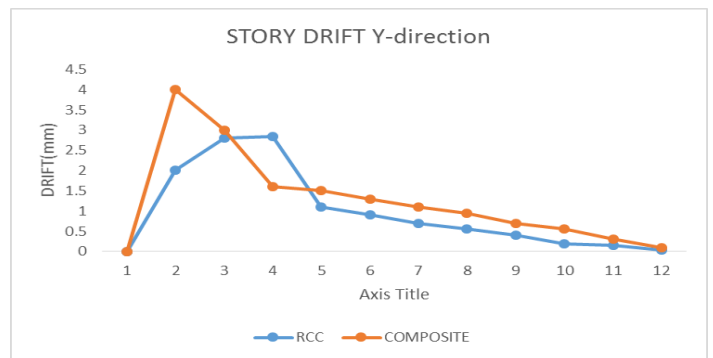

Chart.no.2 DRIFT

5.2 Story Drift

Table.no.3

	RCC		COMPOSITE	
	X dir mm	Y dir(mm)	X dir(mm)	Ydir(mm)
BASE	0	0	0	0
Story1	1.20E-18	5.55E-07	5.58E-17	1.61E-06
Story2	1.99E-18	9.07E-07	3.67E-17	1.05E-06
Story3	2.14E-18	9.60E-07	2.89E-17	8.38E-07
Story4	2.13E-18	9.40E-07	2.59E-17	7.61E-07
Story5	2.08E-18	8.95E-07	2.33E-17	6.92E-07
Story6	2.48E-18	1.06E-06	2.07E-17	6.15E-07
Story7	2.18E-18	9.35E-07	1.80E-17	5.29E-07
Story8	1.79E-18	7.76E-07	1.47E-17	4.33E-07
Story9	1.34E-18	5.97E-07	1.11E-17	3.31E-07
Story10	8.53E-19	4.03E-07	7.31E-18	2.25E-07
Story11	4.04E-19	2.19E-07	3.82E-18	1.28E-07



5.3. DISPLACEMENT DUE TO EARTH QUAKE

Table.no.4

STOR	X-DIR (mm)		Y-DIR (mm)	
	R.CC	COMPOSITE	R.CC	COMPOSITE
0	0	0	0	0
1	2.479	6.772	2.856	7.357
2	5.988	10.68	6.899	11.554
3	9.773	13.956	11.27	15.077
4	13.57	17.081	15.66	18.454
5	17.27	20.086	19.98	21.713
6	21.73	22.919	25.33	24.799
7	25.78	25.505	30.28	27.629
8	29.31	27.754	34.61	30.104
9	32.16	29.565	38.14	32.117
10	34.16	30.836	40.65	33.558

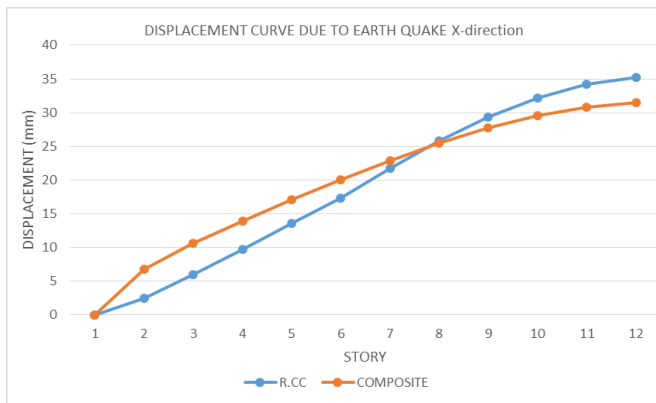

Chart.no.3 DISPLACEMENT DUE TO EARTH QUAKE

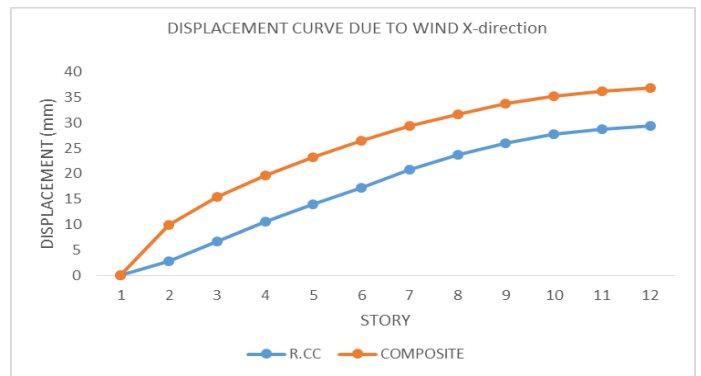
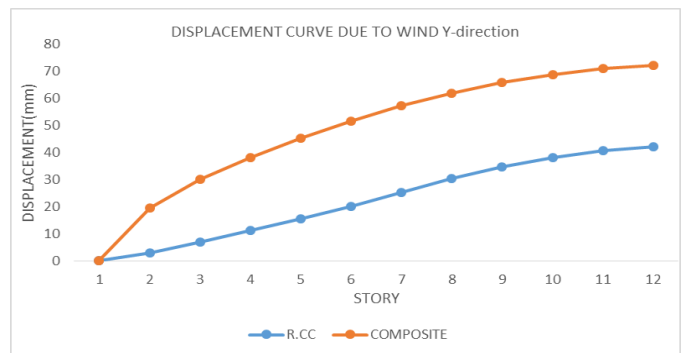
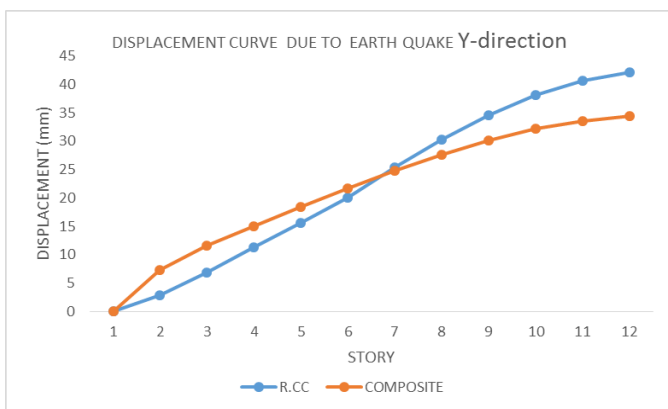

Chart.no.4 DISPLACEMENT DUE TO WIND



5.4. DISPLACEMENT (mm) DUE TO WIND

5.5. OVERTURNING MOMENT (KN-m)

STORY	X-DIR		Y-DIR	
	RCC	COMPOSITE	RCC	COMPOSITE
11	29.32	36.753	42.05	72.29
10	28.79	36.168	40.65	71
9	27.7	35.144	38.14	68.874
8	26	33.652	34.61	65.852
7	23.7	31.7	30.28	61.952
6	20.8	29.303	25.33	57.204
5	17.3	26.476	19.98	51.641
4	14.0	23.235	15.66	45.296
3	10	19.58	11.27	38.175
2	6.69	15.406	6.899	30.083
1	2.873	9.955	2.856	19.523
0	0	0	0	0

Table.no.5

Table.no.6

	RCC	RCC	COMPOSITE	COMPOSITE
	X-dir	Y-dir	X-dir	Y-dir
Base	9.032	-2.45E-12	-7.26354	1.66E-12
Story1	7.63	-2.10E-12	-6.05055	1.38E-12
Story2	6.456851	-1.79E-12	-5.04637	1.15E-12
Story3	5.312929	-1.50E-12	-4.09626	9.29E-13
Story4	4.22807	-1.20E-12	-3.21569	7.29E-13
Story5	3.224352	-9.21E-13	-2.41872	5.35E-13
Story6	2.320647	-6.59E-13	-1.71816	3.80E-13
Story7	1.539093	-4.43E-13	-1.12535	2.44E-13
Story8	0.900795	-2.61E-13	-0.65008	1.35E-13
Story9	0.423267	-1.26E-13	-0.30035	5.00E-14
Story10	0.119971	-2.93E-01	-0.08227	1.63E-14
Story11	-4.89E+15	2.32E+01	1.20E-14	-9.91E-15

**Chart.no.5 OVERTURNING MOMENT**

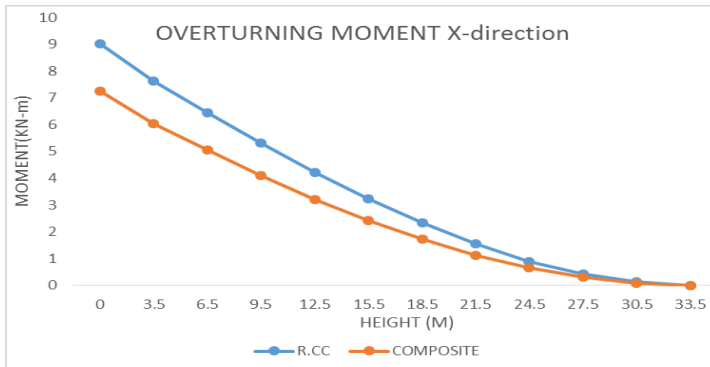

**Chart.no.6 OVERTURNING MOMENT**

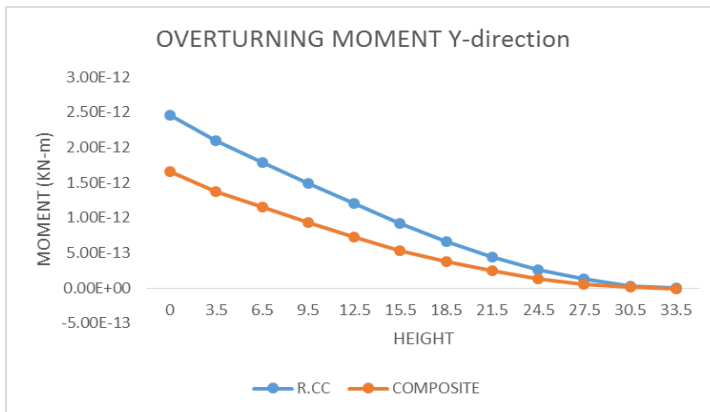

**5.6. PUSHOVER ANALYSIS RESULTS**

**5.6.1 PUSHOVER CURVE VALUES IN X-DIRECTION**

**Table.no.7**

DISPLACEMENT(mm)		BASE SHEAR(KN)	
R.CC	COMPOSITE	R.CC	COMPOSITE
0	0	0	0
43.0328986	112.664	1105.452	1597.942
87.923885	100	1766.12	1634.2
100.346285	171.295	1848.022	2800.187
180.778986	215.082	2070.391	3333.785
256.7543		2215.04	
272.553566		2241.25	
334.004794		2291.032	
352.369686		2300.694	
372.138554		2306.773	
387.234069		2314.08	
450.483407		2332.362	
517.567273		2364.898	

549.09362		2374.471	
555.59161		2377.666	
555.578333		2377.181	

**Chart.no.7 PUSHOVER CURVE**

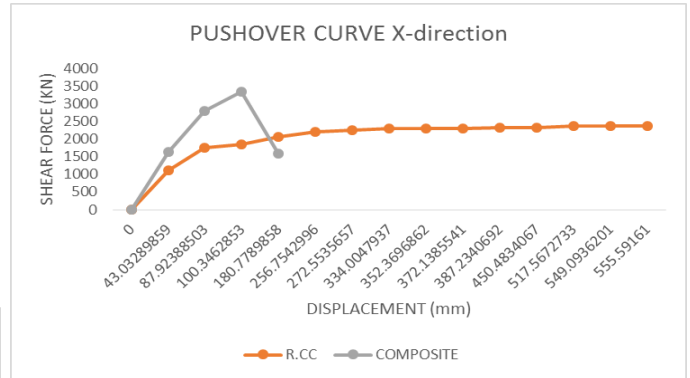

**5.6.2. PUSHOVER CURVE VALUES IN Y-DIRECTION**

**Table.no.8**

DISPLACEMENT(mm)		BASE SHEAR(KN)	
R.CC	COMPOSITE	R.CC	COMPOSITE
0	0	0	0
88.693	100	1920.959	1362.645
104.53	120.102	2174.662	1486.949
153.71	170.193	2659.154	2319.12
162.91	218.424	2704.464	2857.295
254.266		2872.373	
305.11		2926.16	
305.153		2926.164	
319.187		2938.383	
351.841		2952.635	
351.855		2952.607	
352.052		2952.731	

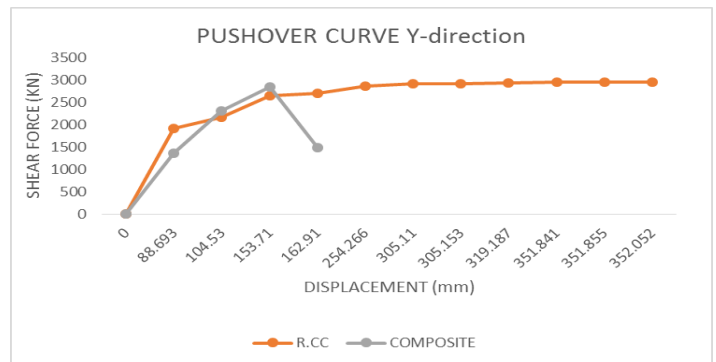

**Chart.no.8 PUSHOVER CURVE**

5.7 PERFORMANCE BASED ANALYSIS

PERFORMANCE POINT OF BUILDINGS IN X-DIRECTION		
	R.C.C	COMPOSITE
SHEAR KN	9361.6	8175.958
DISP(mm)	364.427	500.144
sa g	0.36015	0.2526
sd(mm)	281	400.787
T eff(sec)	1.733	2.527

Table.no.9

Table.no.10

PERFORMANCE POINT OF BUILDINGS IN Y-DIRECTION		
	R.C.C BUILDING	COMPOSITE BUILDING
SHEAR(KN)	8605.93	7475.393
DISP (mm)	397	548.6
sa g	0.333	0.2312
sd(mm)	304.068	436.814
T(sec)	1.917	2.754

Chart.no.9

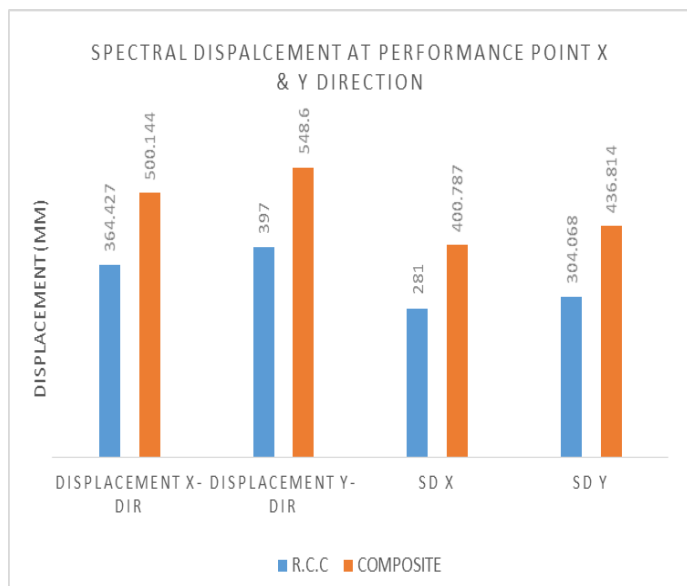

Chart.no.10 TIME PERIOD & SPECTRAL ACCELERATION

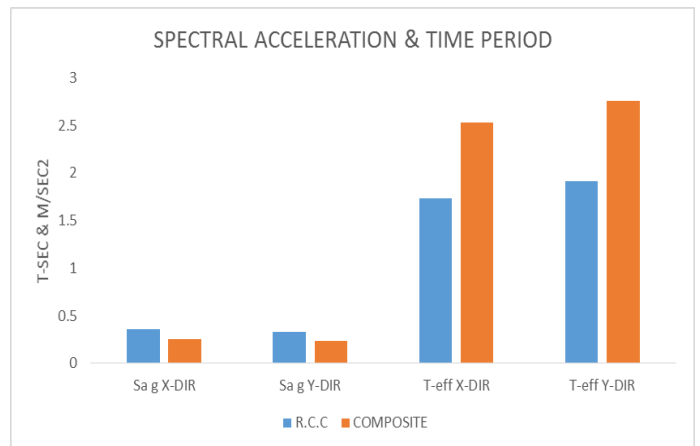
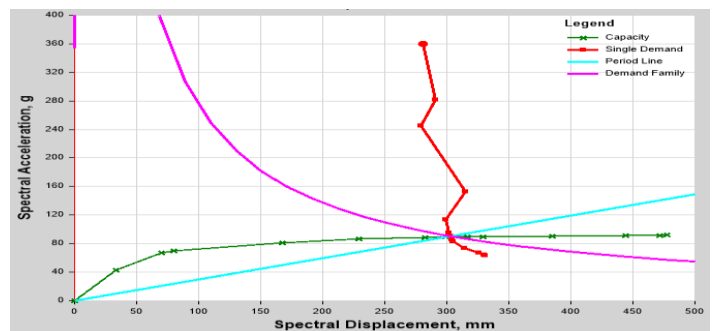
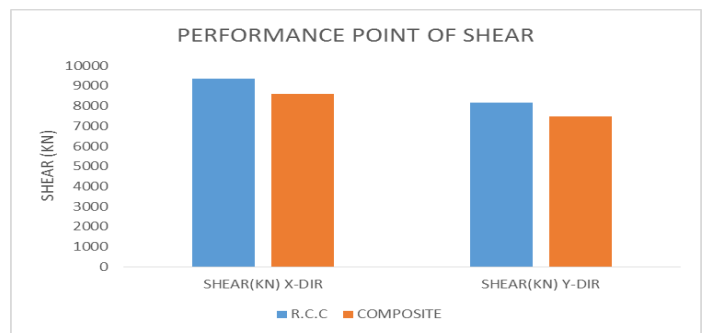
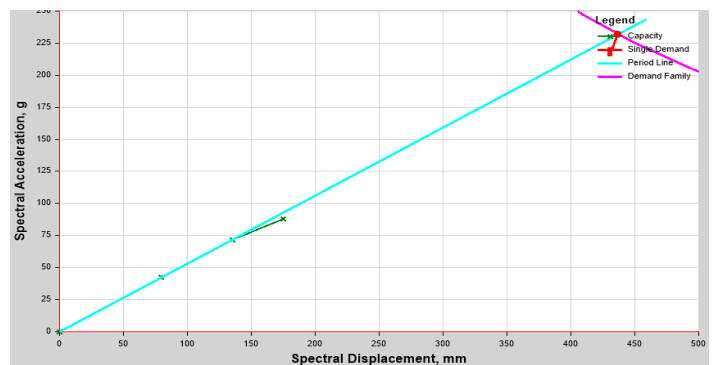

Chart.no.11



PERFORMANCE CURVE OF R.C.C BUILDING

Chart.no.12



PERFORMANCE CURVE OF COMPOSITE BUILDING



5.8. HINGES FORMATION STAGES

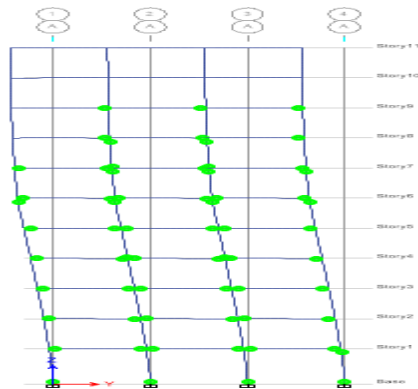

fig.no.7

HINGES FORMATION RCC

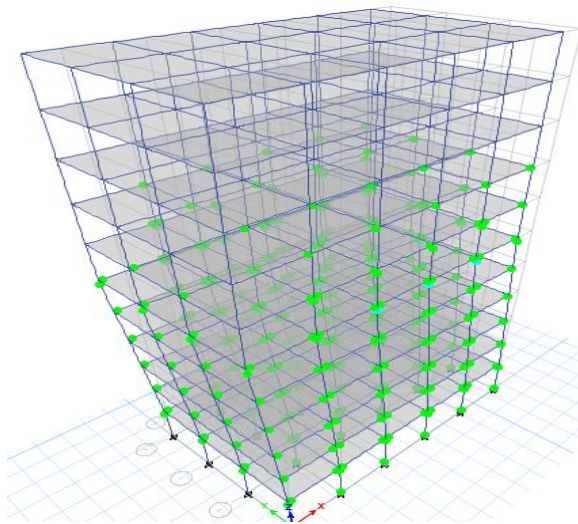

Fig.no.8

HINGES FORMATION STAGE IN COMPOSITE

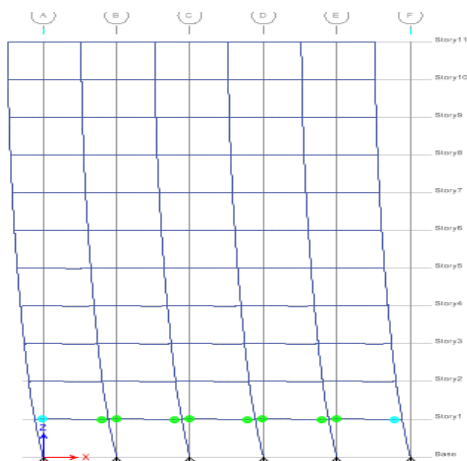

Fig.no.9

6. CONCLUSION

1. Structural Steel-concrete composite has light in weight as compared to RCC which gives economical foundation design.
2. Story drift in Equivalent Static Analysis in X-direction is more for Structural Steel-concrete composite frame as compared to RCC frames.
3. The differences in story drift for different stories along X and Y direction are owing to orientation of column sections. Moment of inertia of column sections are different in both directions.
4. Base Shear for RCC frame is more than Structural Steel-concrete composite because the weight of the RCC frame is more than the composite frame. Base shear gets reduced by 30% for Composite frame.
5. Structural Steel-concrete composite frame having more lateral load capacity compare to RCC frame.
6. The lateral displacement of Structural steel-concrete composite frame is reduced as compared with RCC frame.
7. The overturning-moment of RCC frame is more than Structural Steel-concrete composite because the weight of the RCC frame is more than the composite frame.
8. Composite moment resisting frame has better performance in high seismicity as compared to RCC.
9. No unexpected plastic hinges were observed from inelastic analysis for both RCC & composite frame. But yield mechanism of composite is superior to RCC.
10. Structural Steel-concrete composite frame follows strong column weak beam behavior, as hinges are formed in beam element rather than column element.
11. Structural Steel-concrete composite frame is give good result in pushover curve base shear v/s displacement is less as compared to R.C.C.
12. Structural Steel-concrete composite frame is give good result in Performance Point as compared to R.C.C.
13. Time period of composite is more as compared to RCC
14. According to my study on that I conclude is that Structural Steel-Concrete composite frame is superior as compared to R.C.C in Linear-static Analysis & Linear-Static Dynamic Analysis and NON-Linear Static analysis.
15. But according to result which come after analysis the Structural Steel-concrete composite frame building is less effective to resist wind force compared to RCC due to which building is fail in limiting deflection. If you want to safe the structure to use shear wall in composite building.

ACKNOWLEDGEMENT

First of all I thank the Almighty God, I would like to express my sincerely gratefulness to **Mr. NAZISH** my thesis Co-guide without whom this project could possibly never have been accomplished. He gives me not only large number of significant advice, guidance and comments, but also motivates supervision and encouragement.

There are people without whom this dissertation might not have been possible and to whom I am greatly thankful. Therefore, I would like to acknowledge:

My supervisor **MISBAH DANISH SABRI**, Assistant Professor and Project Guide, Department of Civil Engineering, AL-FALAH University who was not simply supervisors, but also friends and mentors. Without him and his wealth of knowledge, patience and reliability; I could not reach this far.

## REFERENCES

1. **D. R. Panchal and P. M. Marathe**, "Comparative Study of R.C.C, Steel and Composite (G+30 Storey) Building ", Institute of Technology, Nirma University, Ahmedabad – 382 481, December, 2011.
2. **R.P.Johnson**, "Composite structures of steel and concrete" Volume-1, Blackwell Scientific publications, UK.1994.
3. **J.M. Castro, A.Y. Elghazouli and B.A. Izzuddin**, Performance assessment of composite moment-resisting frames. 29th the 14th world conference on earthquake engineering, Beijing, China october 12-17, 2008
4. **Liu Jingbo and Liu Yangbing**, Seismic behaviour analysis of steel-concrete composite frame structure systems, The 14th World Conference on Earthquake Engineering, Beijing, China, October 12-17, 2008
5. **Yangbing Liu, Yuanxin Liao & Nina Zheng**, Analysis of Strong Column and Weak Beam Behaviour of Steel-concrete Mixed Frames, The 15th World Conference on Earthquake Engineering, Lisboa, 2012 **Liang, Q.**
6. **Hadi, M. N. (2008)**. Nonlinear analysis and behavior of concrete-filled steel tubular beam-columns. Structural Engineering and Construction Conference, London, (pp. 777-782)
7. **Ricardo Herrera, Brian Lewis, James Ricles, Richard Sause**, Experimental studies on steel moment resisting frames with concrete filled tube columns under earthquake loading conditions, 13th World Conference on Earthquake Engineering, Vancouver, B.C., Canada, August 1-6, 2004 Paper No. 1591.
8. **QI Jing-jing, Jiang Li-zhong**, Experimental study on seismic behaviors of steel-concrete composite frames, international journal on engineering, medical & science, J. Cent. South Univ.
9. **J. Y. Richard Liew, Hong Chen, and N. E. Shanmugam**, ASCE, *Journal of Structural Engineering*, 2001, 127(2)
10. **Barbato, Michele**, LSU, Nonlinear seismic response analysis of steel-concrete composite frames, *Journal of Structural Engineering*, 134(6), 01-01-2008.
11. **M.Elchalakani, X.L. Zhao, R.H. Grzebieta**, Concrete-filled circular steel tubes subjected to pure bending, *Journal of Constructional Steel Research* 57 (2001) 1141–1168,
12. **Cui Chunyi, Zhao Jinfeng, Zhang Yannian and Zuo Wenxin**, Experimental Analyses of Mechanical Performance of CFST Column to Assembled Steel H-Beam Connections, *The Open Mechanical Engineering Journal*, 2014, 8, 270-278,

12. **Donglin Wang, Li Wang**, Nonlinear Analysis of the New Composite Frame Structure, *International Journal of Nonlinear Science* Vol.11(2011) No.2

13. **IS:456**, Code of practice for plain and reinforced concrete code of practice, Bureau of Indian Standards, New Delhi, 2000.

14. **IS:1893**, Criteria for earthquake resistant design of structures - general provisions for buildings, Part 1, Bureau of Indian Standards, New Delhi, 2002.

15. **IS:875**, "code of practice for design load (other than earthquake) for buildings and structures" Bureau of Indian Standards, New Delhi, 2002.

16. **IS:800**, Code of practice for general construction in steel, Bureau of Indian Standards, New Delhi, 2007.

17. **IS:11384**, Code of practice for composite construction in structural steel and concrete, Bureau of Indian Standards, New Delhi, 1985. D. Kornack and P. Rakic, "Cell Proliferation without Neurogenesis in Adult Primate Neocortex," *Science*, vol. 294, Dec. 2001, pp. 2127-2130, doi:10.1126/science.1065467.

18. FEMA 356, FEMA 440 EL, FEMA 276 and ATC-40 is used for pushover analysis.

## BIOGRAPHY



### MOHD AMIR KHAN

M.Tech (Structural & Foundation Engineering)

Department of Civil Engineering AL-FALAH University, Faridabad INDIA