

IoT Based Control and Monitoring of Smart Grid and Power Theft Detection by Locating Area

S S Nagendra Kumar¹, S Koteswara Rao², M Suresh Raju³, S Trimurthulu⁴,
K Sivaji⁵, T Ram Manohar Reddy⁶

^{1,2,3,4,5,6} Electrical and Electronics Engineering, Pragati Engineering College, Kakinada, India.

Abstract—IOT based Smart Grid is an evolution of the existing electricity grid. Advancement in high speed communication and low cost sensor coupled with the increased deployment of the advanced provide utilities with better information to manage the grid. It comprises of a two-way communication where electricity and information are exchanged by the consumer and utility to maximize efficiency. The control center ensure the smart grid optimize circuit VAR flow and voltages, there by power theft location can be monitored with help of the smart transformers and smart energy [1] meters.

pi communication hub, which has a wireless connection to every smart meters in that area. The zigbee module which transfer the smart meter data to the hub. The entire digital data is sent to the azure cloud platform (internet) through raspberry pi. The electrical bills a automatically generated in the internet(cloud).

This system aslo helps the consumers to monitor their daily usage of electricity through internet. He can able to control the heavy appliances to reduce his electrical billing. The communication between the consumer and utility increases the efficiency and reliability.

INTRODUCTION

Introducing Raspberry Pi in the electrical grid makes the grid as smart grid. The important information are sent to cloud (Azure), collected by various sensors by using Raspberry Pi. So the Data Analytics is performed by the Azure cloud, which gives the performance and characteristics of the electrical grid. This paper proposes Smart grid systems consist of digitally based sensing, communications, and control technologies and field devices that function to coordinate multiple electric grid processes. A more intelligent grid includes the application of information technology systems to handle new data and permits utilities to more effectively and dynamically manage grid operations. The information provided by smart grid systems also enables customers to make informed choices about the way they manage energy use.

The smart grid is more advance than the normal electric grid. The demand of electric power is increased today. In some of the area's the power theft is frequently done, this can be reduced if we area of power theft. The identification of the location can be done as a part of smart grid [2] through VAR acquisition.

By using the IOT technology the grid can be digitalized and detect every changes in it. The system has a two communication between the consumer and utility. The Raspberry Pi which is used for controlling and data transfer between sending end and receiving end side through cloud.

The consumer have a smart meter which consist of Arduino Uno and Zigbee. For each area there is raspberry

BLOCK DIAGRAMS

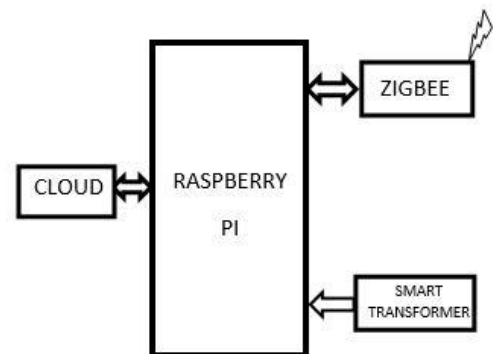

Fig-1: Raspberry pi hub for an area

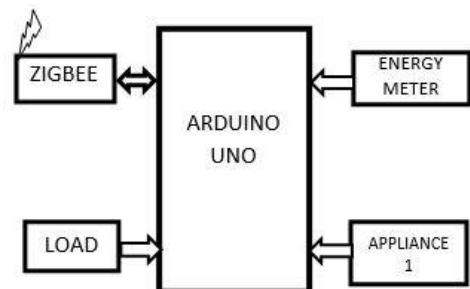

Fig-2: Consumer 1

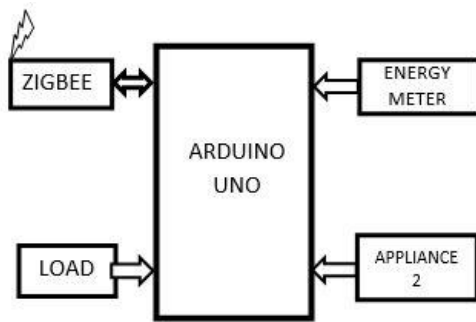

Fig-3: Consumer 2

Fig(1), Fig(2) and Fig(3) represents the overall block diagram of the proposed system. The consumer has a smart app for receiving the information and able monitoring the daily electrical energy consumed. If any problem in the smart meter, the raspberry pi cannot get the information of the units from it. So the raspberry pi makes the complaint automatically by providing a serial no of smart meter (address is known from sql database).

LOCATION OF THE POWER THEFT

When coming to power theft, in earlier day the energy meters are analog, so the consumers use two permanent magnets which are place to the meter so the disc is structured and not able to make its rotation. This illegal way of theft can be reduced by using digital meters. Even though using digital meters, the power theft cannot be reduced since there is a chance of bi-passing the meter. So the following method can predict the power theft by locating the area using smart meters and smart transformers. Smart transformer measure the total power consumed i.e., total power consumed at transformer(Ptot) by the consumer loads. The each consumer smart meter sent the power consumed by each consumer to the hub through zigbee(P1, P2, P3....).The power from sending end should be equal to receiving end.

$$P_{tot}=P1+P2+P3+.....$$

The raspberry pi perform this calculation, if the equation is not satisfied, the location of that area is sent to the respective officer messaging that there is a power theft. (As in table1)

PEAK DEMAND

When day warms the air condition units start to come online, the power factor is continuously optimize to reduce feeder system losses. During this time the raspberry pi inform the control room. Based on the situation and availability of the renewable sources he decides the technique.

1.The operation steam utilizes volt VAR optimization system to reduce real power demand by lowering feeder voltages within approved limits. Distributed energy

resource management software lets the utility forecast aggregate and efficiently manage the renewable energy system and battery energy storage connected to the distribution grid. This help to reduce both fossil fuel generation and peak demand.

2. Changing the price per unit, so the consumer gets notified the price per unit through the app.(As in table2)

3. Fixing the power consumed by every smart meter, the consumer gets notified. If the power limit is exceeds the consumer is notified that he is crossing the limit. So he switch off heavy appliances within the specific time. Or else the smart meter is tripped.

AUTOMATICALLY INFORMING THE CONSUMERS DURING FAULTS

A tree has fallen across the power line causing a permanent fault, the outage management system automatically assesses the impact of the storm estimates restoration time and notifies customers,(As in table3). To avoid any power disruption the hospitals micro grid control system disconnects it from the power grid. It immediately activates the energy storage system and starts the on-site generation to serve critical loads until power restored. Automate electrical switching devices work together to communicate details back to the control center in order to isolate the faulted zone and restore power all areas possible. Based on the information received from the outage management system right service truck with the right equipment is quickly dispatched to the fault location with the local circuit safely isolated the service screw can start working as soon as they arrive. Service crews repair the fault inspect the line and alert the control center that the circuit can be re-energized and the grid can be restored to normal operations.

With things back to normal the smart grid [2] continues to optimizes the power factor and voltages quality to improve grid efficiency. Smart sensors on transformers, circuit breakers and other devices in digital substations provide both operational and non-operational data analytics delivered by asset health software help utility personnel better forecast equipment life cycles and maintenance requirements.

RETURN EXCESS POWER TO GRID

The shopping center has installed solar panels that help power the stores and return excess power to the grid(as in table4), the installation of these panels lowers energy costs for the owner and helps the utility meet renewable portfolio standards energy storage helps to address the variability of renewable generation and can reduce peak demand. The bi-directional meters are used in this, in any problematic condition or generated power is not sufficient then the required amount of power is taken from the grid.

INTERNET OF THINGS AND AZURE CLOUD

The Internet of things (IoT) is the inter-networking of physical devices and other items—embedded with electronics, software, sensors, actuators, and network connectivity that enable these objects to collect and exchange data.

Here in our project, we are uploading and retrieving data from Cloud using the Internet facility provided default by the hardware in our system (Raspberry Pi 3) at hub. All the data say the Power Unit Monitored at Grid Side, the data received from Consumer Side, Comparison between both Units and Exceeded Units, etc... are possible through this IoT concepts using WAN facility. Updating this kind of data's are possible in many ways like TCP/IP, UDP/IP, Web-based Apps or Scripts or particular Webpage, etc....etc.

Microsoft Azure, formerly known as Windows Azure, is Microsoft's public cloud computing platform. It provides a range of cloud services, including those for compute, analytics, storage and networking. Users can pick and choose from these services to develop and scale new applications, or run existing applications, in the public cloud. It has a service like machine learning, data storage, analytics, IAM, management and security.

DESCRIPTION

8.1.RASPBERRY PI 3

The Raspberry Pi 3 Model B is a quad-core processor that runs at 900MHz, it also has 4*ARM cortex-A53 with 1.2GHz. The raspberry pi 3 has a inbuilt wifi. The OS can be used Raspbian or windows 10 IOT core.
 SOC : Broadcom BCM2837
 CPU: 4 * ARM cortex-A53, 1.2GHz
 GPU: Broadcom VideoCore IV
 RAM: 1GB LPDDR2 (900MHz)
 NETWORKING: 10/100 Ethernet, 2.4GHz 802.11n wireless
 BLUETOOTH: Bluetooth 4.1 classic, Bluetooth Low Energy
 STORAGE: microSD
 GPIO: 40 pin headed, populated
 PORTS: HDMI, 3.5mm analogue audio-video jack, 4* USB 2.0, Ethernet, Camera serial interface (CSI), Digital serial interface(DSI). Raspberry Pi 3 Model B is as shown in fig(4).

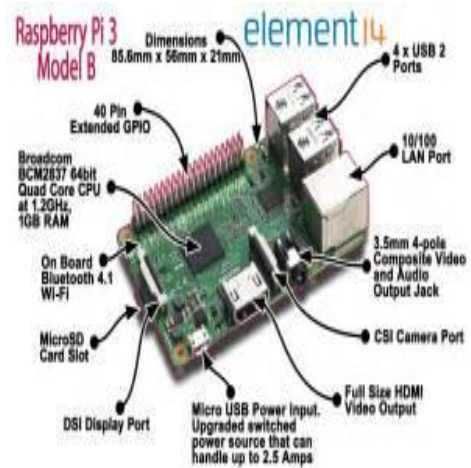

Fig(4): Raspberry Pi 3 Model B

8.2.ARDUINO

Arduino is an open-source prototyping platform based on easy-to-use hardware and software. Arduino boards are able to read inputs - light on a sensor, a finger on a button, or a Twitter message - and turn it into an output - activating a motor, turning on an LED, publishing something online. You can tell your board what to do by sending a set of instructions to the microcontroller on the board. To do so you use the Arduino programming language (based on Wiring), and the Arduino Software (IDE), based on Processing.



Fig(5): Arduino Uno

Over the years, Arduino has been the brain of thousands of projects, from everyday objects to complex scientific instruments. A worldwide community of makers - students, hobbyists, artists, programmers, and professionals - has gathered around this open-source platform, their contributions have added up to an incredible amount of accessible knowledge that can be of great help to novices and experts alike. The arduino unit is as shown in fig(5).

Specifications:

- Microcontroller ATmega 328
- Operating voltage 5V
- Input voltage 7-12V Input voltage (limits) 6-20V
- Digital I/O pins 14(of which 6 provide PWM output)
- Analog Input Pins 6

DC Current per I/O Pin 40 mA
 DC Current for 3.3V 50 mA
 Flash Memory 16 KB (ATmega168) or 32 KB (ATmega328)
 of which 2 KB used by bootloader
 SRAM 1 KB (ATmega168) or 2 KB (ATmega328)
 EEPROM 512 bytes (ATmega168) or 1 KB (ATmega328)
 Clock Speed 16 MHz

8.3.ZIGBEE

Zig-bee is a communication device used for the data transfer between the controllers, computers, systems, really anything with a serial port. As it works with low power consumption, the transmission distances are limited to 10–100 meters line-of-sight. Zig-bee devices can transmit data over long distances by passing data through a mesh network of intermediate devices to reach more distant ones. Zigbee is typically used in low data rate applications that require long battery life and secure networking. Its main applications are in the field of wireless sensor network based on industries as it requires short-range low-rate wireless data transfer. The technology defined by the Zig-bee specification is intended to be simpler and less expensive than other wireless networks.

Here we make use of an interface of Zig-bee with Raspberry Pi3 for a proper wireless communication. Raspberry Pi3 has got four USB ports, so it is better to use a Zig-bee Dongle for this interface. Now we want to check the communication between the two paired Zig-bee modules. The two Zigbee must be paired with the same baud rate (for Ex: 9600) with X-CTU Software. Attach the two Zigbee's to the two dongle's and connect one pair on the USB port of the Raspberry Pi3. Connect the other pair to the USB port of a computer or a Laptop. Install the FTDI Driver on the Computer /laptop to provide USB communication. The response showed inside a red box indicates the presence of an USB device in the module. Write a python script to perform Zig-bee communication which is given. The Zigbee module is as shown in fig(6)

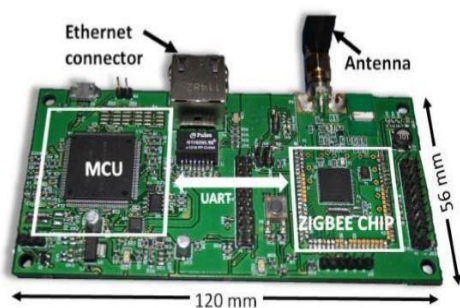

Fig(6): zigbee

SOFTWARE USED:

The Raspberry Pi can be used to automate a smart grid [2] at a relatively low cost. It operates on the concept as the IoT. There are numerous things that make the Raspberry Pi essential for grid automation but the one that stands out the most has to be the remarkably affordable cost. The vast amount of sensors at extremely low cost makes it's super for smart grid [2] automation. The Raspberry Pi can be programed to be a security system with as many sensors as you desire, for a fraction of the cost.

Raspberry Pi 3 Model B In the present study an IP-based network was established, Python codes were written for the sensors, which were connected to the Pi, a command was then carried out from the network website, which was processed by the Pi and reacted with the connected sensors. The purpose of present study is to build a system of interconnected devices and sensors, which allow the user to control and monitor energy meter via the internet from the Raspberry Pi.

Results and Discussion:

Very soon in near future, the traditional grids of today will evolve into a robust, effective, environment-friendly and energy efficient system known as the Smart Grid. It simplifies the work of the electricity board in tripping the supply to a particular customer in case of electricity theft etc. It helps the customer in knowing about the tariff variation. It enables transceiver interfaced with the EB section server as well as in the consumer side. Power consumed by the consumer is monitored by EB through zigbee technology. smart grid technologies are now providing information streams that are beginning to advance utility operations and business processes, while engaging residential, commercial, and industrial consumers in electricity management and even production.

Table1: Power theft detection

Power Theft	Location
YES	ADB Road, Transformer1

Table2 : Peak Demand reduction

Peak demand	Price	consumer
YES	>normal	Notified
NO	Normal	-----

Table3: fault detection

Fault Detection	Location	Consumers
Yes	ADB road, Area2	Cleared in 30 minutes



Table 4: Excess power to grid



Consumer Power Pooling	Substation aggrement	Smart meter
Yes	Accepted	Acts as Bi-directional meter
Yes	Not accepted	No change

REFERENCE

- [1] J. Byun, I. Hong, B.Kang, and S.Park, (May 2011)—A smart energy Distributed management system for renewable energy distribution and context aware services based on user patterns and load forecasting,|| IEEE Trans. Consum. Electron., vol. 57, no. 2, pp. 436–444.
- [2] Elisa Spanò, Luca Niccolini, Stefano Di Pascoli, and Giuseppe Iannaccone (JANUARY 2015) —LastMeter Smart Grid Embedded in an Internet-of-Things Platform|| IEEE TRANSACTIONS ON SMART GRID, VOL. 6, NO. 1.
- [3] Modern Power System Analysis by I.J Nagarath and D.P.Kothari, Tata Mc Graw Hill, 2nd edition.
- [4] Power System Analysis – by John J Grainger William D stevenson, TMC Companies, 4th edition.

BIOGRAPHIES

	S Trimurthulu pursuing Electrical and Electronics Engineering at Pragati Engineering College, Kakinada, India.
	K Sivaji pursuing Electrical and Electronics Engineering at Pragati Engineering College, Kakinada, India.
	T Ram Manohar Reddy pursuing Electrical and Electronics Engineering at Pragati Engineering College, Kakinada, India.

	S S Nagendra Kumar pursuing Electrical and Electronics Engineering at Pragati Engineering College, Kakinada, India. Interested in Digital Power Grid and innovation in power system.
	S Koteswara Rao pursuing Electrical and Electronics Engineering at Pragati Engineering College, Kakinada, India.
	M Suresh Raju pursuing Electrical and Electronics Engineering at Pragati Engineering College, Kakinada, India.