

IMPLEMENTATION AND CONTROLLING OF ELECTRICAL APPLIANCES BY USING BLUETOOTH

G JYOTHI KIRAN¹, K SATYA SURENDRA², S A MOHIDDIN³, M KRISHNA⁴, S SANTHOSH KUMAR⁵

^{1,2,3,4,5} B.Tech Student Scholar, Pragati Engineering College, Andhra Pradesh, India

Abstract - Home Automation is a technological evolving subject, permitting to build smart houses. In a smart house, there is a home area network with all devices interconnected. These devices can be monitored and controlled by the homeowner inside or outside the house, and information can be exchanged between them. Home automation systems permit to improve comfort, security and energy efficiency at home. Energy efficiency management is a more recent add-on to Home Automation systems. Energy efficiency management intends to optimize the usage of electrical devices, connecting and disconnecting devices based on real-time price of electricity. Wireless technologies permit to implement the home area network, avoiding the use of additional wires. Wi-Fi, Bluetooth, ZigBee and Z-Wave are possible options, but Bluetooth Low Energy (BLE) is selected due to the reduced power consumption, low cost, and easy connection to tablets and smartphones.

1. INTRODUCTION

In designing a electrical automation[5] system, one or more suitable platforms are used in order to build a dependable and flexible system that can be easily operated and adapted for a new electrical appliance. Therefore, for the purpose of this project some specific deliberate choices were made on the type of platforms, hardware components and process mode of domestic automation system. Bluetooth[3][4] domestic automation is a project based on controlling of domestic appliances using Bluetooth[3][4] module, microcontroller, and android phone. The designed domestic automation system uses ATMEGA328 microcontroller, an android mobile phone that has Bluetooth hardware, UARTS standard for communication between the microcontroller, and the Bluetooth[3][4] module of the domestic automation' system. The design will also use TRIAC and a driver for interfacing. Microcontroller[6] controls the switch 'ON' or 'OFF'. The designed system describes how to use the android Bluetooth APIS to accomplish the four major tasks necessary to communicate using Bluetooth: setting up Bluetooth, finding devices that are either paired or available in the local area, connecting devices, and transferring data between devices. All of the Bluetooth APIS are available in the android Bluetooth package. In order to use Bluetooth features in application, it must declare the Bluetooth permission. Permission to perform

any Bluetooth communication is needed, such as requesting a connection, accepting a connection, and transferring data. Before the actual design of the project work, specific deliberate choices in selection of appropriate implementation platforms and hardware components were made. Priority was given to low cost availability, reliability, flexibility and simplicity in all these selections.

2. EXISTING SYSTEM

Existing system is generally a complex task in our day to day life. For eg when a television is to be operated it is to be controlled using a remote. When an AC is to be operated it should controlled initially with a remote.

So all the existing systems in the modern world are to be controlled using a device or a chip. so all the existing systems are less efficient compared with proposed system.

The model for electrical appliances using Bluetooth via PC has been implemented, But unfortunately the system lacks to support mobile technology[1]. The objective of this proposal was to develop a controlling strategy of Electrical appliances[5] based on Bluetooth wireless technology. The result is the HAP, which allows the user to monitor and control different appliances connected over a Bluetooth network in the environment. In this system, the error detection and correction facility is only handled at the Bluetooth level. Similar facility can be developed at the application level. Also, some security measures to avoid interference of neighboring electrical systems can also be incorporated into the application. The functionality of the HAP can be tested for a larger network, using multiple Bluetooth devices. For this project, we have used I2C interface between the DC and the ADs. One can explore the possibility of a parallel interface for faster appliances, or power line interface, etc. In our application one Bluetooth module is associated with only one DC. However, one can assess the viability of a multi-drop RS232 interface between a Bluetooth module and DCs. Of course, in ideal situation, each appliance will have its own Bluetooth module. With the explosion Internet and related technologies, the home system looks set to enter this arena.

3. PROPOSED SYSTEM

Initially the 230V power supply is given to the transformer from supply mains. The 230V is converted to 12V by using step-down transformer. This 12V is given to the Bridge rectifier where it converts AC to pulsating DC. This pulsating DC is filtered to pure DC by the Ripple avoider (Capacitor) and this 12V is given to the Micro controller and Micro controller is connected to the Bluetooth module. This Bluetooth module receives the signal from an Android mobile which is given by the user. That signal is given to the Micro controller then controller passes the signal to the connected loads through the Relay circuit. In this we have two loads like AC lamp and DC fan.

“These loads will operate depends on the command (ON/OFF) which is given by the user. The ON/OFF operation will depends on the range of Bluetooth.

The basic Block diagram deals with a power supply unit which is nothing but an electronic device that supplies electric energy to an electrical load. The primary function of a power supply is to convert one form of electrical energy to and, as a result, power supplies are sometimes referred to as electric power converters. Every power supply must obtain the energy it supplies to its load, as well as any energy it consumes while performing that task, from an energy source. Depending on its design, a power supply may obtain energy from various types of energy sources, and the output of the Power supply unit is fed back to the Transformer unit.

A transformer is an electrical device that transfers electrical energy between two or more circuits through electromagnetic induction. A varying current in one coil of the transformer produces a varying magnetic field, which in turn induces a voltage in a second coil. Power can be transferred between the two coils through the magnetic field, without a metallic connection between the two circuits. Transformers are used to increase or decrease the alternating voltages in electric power applications. Here the 230V input which is obtained by means of power supply is given to the primary of the transformer where it step downs to a voltage of 12V AC by means of a suitable Step down transformer. The Output of the transformer is given to the Bridge Rectifier.

A diode bridge is an arrangement of four (or more) diodes in a bridge circuit configuration that provides the same polarity of output for either polarity of input. When used in its most common application, for conversion of an alternating current (AC) input into a direct current (DC) output, it is known as a bridge rectifier. The main functioning of this Bridge rectifier is to convert the obtained 12V AC supply from the transformer to the 12V DC supply by means of a rectifier. Here the obtained DC supply is fed through the ripple avoider in order to eliminate the ripples. The output of the ripple avoider is

given to the Arduino Board where it works purely in the form of 12V DC supply. Here the Voltage Regulator is incorporated in order the maintain the constant DC voltage from 12V DC to 5V DC where the Microcontroller works on 5V DC supply.

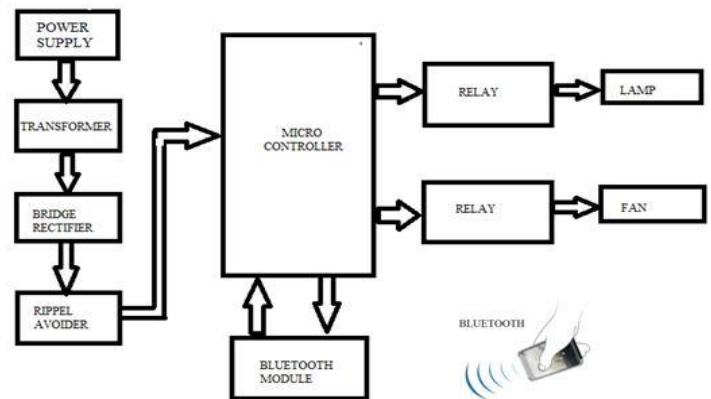

Fig -3.1: Block diagram of electrical appliance

The ATmega48A/PA/88A/PA/168A/PA/328/P is a low-power CMOS 8-bit microcontroller based on the AVR enhanced RISC architecture. By executing powerful instructions in a single clock cycle, the ATmega48A/PA/88A/PA/168A/PA/328/P achieves throughputs approaching 1 MIPS per MHz allowing the system designer to optimize power consumption versus processing speed. The high-performance Atmel 8-bit AVR RISC-based microcontroller combines 32 KB ISP flash memory with read-while-write capabilities, 1 KB EEPROM, 2 KB SRAM, 23 general purpose I/O lines, 32 general purpose working registers, three flexible timer/counters with compare modes, internal and external interrupts, serial programmable USART, a byte-oriented 2-wire serial interface, SPI serial port, 6-channel 10-bit A/D converter programmable watchdog timer with internal oscillator, and five software selectable power saving modes. The device operates between 1.8-5.5 volts. The output of the Microcontroller is fed back to the solid state relay in order to Switch ON/OFF the suitable load. This can be done by means of Bluetooth mechanism where we control the Electrical appliances by means of sending proper command to the microcontroller to operate.

3.2 SCHEMATIC DIAGRAM

Initially the 230V power supply is given to the transformer from supply mains. The 230V is converted to 12V by using step-down transformer. This 12V is given to the Bridge rectifier where it converts AC to pulsating DC. This pulsating DC is filtered to pure DC by the Ripple avoider (Capacitor) and this 12V is given to the Micro controller and Micro controller is connected to the Bluetooth module. This Bluetooth module receives the signal from an

Android mobile which is given by the user. That signal is given to the Micro controller then controller passes the signal to the connected loads through the Relay circuit.

In this we have two loads like AC lamp and DC fan. "These loads will operate depends on the command (ON/OFF) which is given by the user. The ON/OFF operation will depends on the range of Bluetooth. Here the 230 volts supply is directly given to the AC lamp by means of a solid state relay. The Relay consists of five pins. The 230 volts ac supply is connected to the normally closed(NC) pin of the relay. A 12 volts dc supply is connected to the positive pin of the relay to give the supply to the relay. The negative pin of the relay is connected to the arduino board for the signal for switching operation of relay. The common pin is connected to one end terminal of the bulb and the other end of the bulb is connected to the earth.

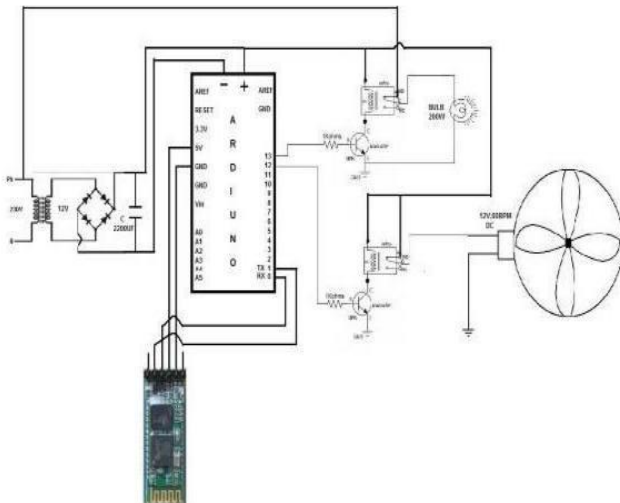

Fig-3.2: schematic diagram of electrical appliance

When an electric current is passed through the coil it generates a magnetic field that activates the armature, and the consequent movement of the movable contact either makes or breaks a connection with a fixed contact. If the set of contacts was closed when the relay was de-energized, then the movement opens the contacts and breaks the connection, and vice versa if the contacts were open. When the current to the coil is switched off, the armature is returned by a force, approximately half as strong as the magnetic force, to its relaxed position.

3.3 ADVANTAGES

- It reduces human effort/stress and saves time.
- It brings total flexibilites to electric power switching with in a locality.
- It reduces mechanical switch bouncing and noise.

- We can control devices from a long distance, thus it gives ease of access.
- Faster operation and efficient.
- No need to carry separate remote or any other controlling unit.
- Economical in cost.
- Requires Less maintaince.
- Efficiency is higher than that of all systems to the existing systems.
- Old people and ph candidates can easily access.
- We can get a faster response when we give input signal.

4. RESULT

The main Aim of our project is to control an Electrical appliances by means of Bluetooth technology by giving a proper command through mobile. Here we are using 11 commands in order to control an Electrical Appliances.



Fig-4.1:Both Motor and Lamp are Off

Case (i) When the power supply is given to our circuit then the circuit is ready to work,but this is an initial case. In this case the Lamp and Motor are said to be in off state position as shown in the fig 4.1

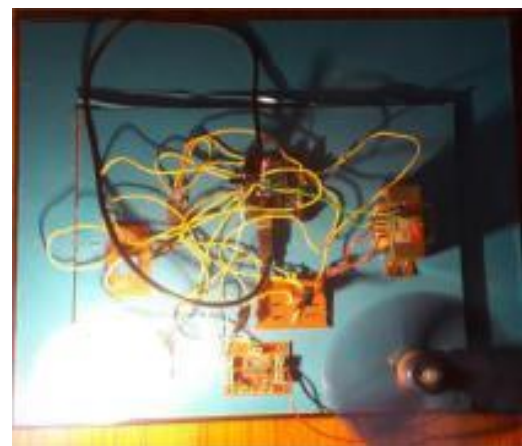

Fig-4.2:Both Motor and Lamp are On

Case (ii) When the input signal is given by using Bluetooth then both the appliances are said to be in ON state position as shown in the fig 4.2

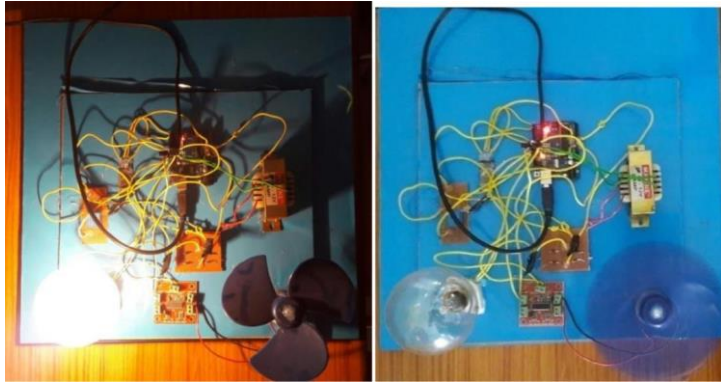

Fig-4.3:Lamp on, Motor Off Fig-4.4:Lamp Off Motor On

Case (iii) When an input signal is given by means of Bluetooth the Lamp is ON and the Motor is OFF as shown in fig 4.3

Case (iv) Similarly the Motor is ON and Lamp is OFF as shown in the fig 4.4

Here the commands are also presented in detailed for there corresponding operation

TABLE-1:(Operating Commands)

Commands	Result
1	Motor on
2	Lamp on
3	Both on
4	Motor off, lamp on
5	Motor on,lamp on
6	Both off
7	Anti clock Reduction
8	Anti clock speed
9	Brake
*	Clock speed
#	Clock speed Reduction

5. CONCLUSIONS

Through the medium, how to develop a Bluetooth based domestic automation using Android smart phone has been described, designed and constructed to control 220V+5% ac load. It is rated 2KW, 50Hz. The developed system eliminates the stress of human manual switching and to introduce flexibility of control without direct contact to switches even such that could be easily done via an android phone application at any comfortable point at domestic premises within the wireless coverage distance. The system makes switching boundless within the

Bluetooth 10m coverage. Thus this paper has achieved its target using the architecture of a Bluetooth based switching automation of domestic electrical powered appliances through application software on android phone platform. With this, user can switch appliances 'ON' and 'OFF' on his/her bed or any comfortable spot through hand android phone. Nevertheless, the user usage distant is limited to the Bluetooth coverage length of about 10 meters. Future research may be geared towards developing a household switching device that can beyond 10m coverage however without charges. Two layers circuit board can be designed and used in place of single layer circuit board for easier soldering work and neatness to commercialize the product.

6. FUTURE SCOPE

Through the medium, how to develop a Bluetooth based domestic automation using Android smart phone has been described, designed and constructed to control 220V+5% ac load. It is rated 2KW, 50Hz. The developed system eliminates the stress of human manual switching and to introduce flexibility of control without direct contact to switches even such that could be easily done via an android phone application at any comfortable point at domestic premises within the wireless coverage distance. The system makes switching boundless within the Bluetooth 10m coverage. Thus this paper has achieved its target using the architecture of a Bluetooth based switching automation of domestic electrical powered appliances through application software on android phone platform. With this, user can switch appliances 'ON' and 'OFF' on his/her bed or any comfortable spot through hand android phone. Nevertheless, the user usage distant is limited to the Bluetooth coverage length of about 10 meters. Future research may be geared towards developing a household switching device that can beyond 10m coverage however without charges. Two layers circuit board can be designed and used in place of single layer circuit board for easier soldering work and neatness to commercialize the product.

REFERENCES

[1] P.Pillay and R.Krishnan, "Modeling, simulation and analysis of Permanent-magnet motor drives, part-II: the brushless DC motor drives," IEEE Trans. on Industry Applications, vol. 25, pp.274- 279, March/April1989.

[2] Joachima Holtz, Senior member, IEEE "Pulse Width Modulation- A survey", IEEE Transaction Industrial Electronics, Vol. 39, No.5, December 1992, pp 410-420.

[3] N. Sriskantha and Ta Karad. Bluetooth Based Home Automation System. Journal of Microprocessors and Microsystems, Vol. 26, pp.281-289, 2002.

[4] Al-Ali, Member, IEEE & M. AL-Rousan, "Java-Based Home Automation System ." IEEE Transactions on Consumer Electronics, Vol. 50, No. 2, MAY 2004.

[5] Muhammad Izhar Ramli, Mohd Helmy Abd Wahab, Nabihah, "TOWARDS SMART HOME:CONTROL ELECTRICAL DEVICES ONLINE" ,Nornabihah Ahmad International Conference on Science and Technology: Application in Industry and Education (2006).

[6] E. Yavuz, B. Hasan, I. Serkan and K. Duygu. "Safe and Secure PIC Based Remote Control Application for Intelligent Home". International Journal of Computer Science and Network Security, Vol. 7, No. 5, May 2007.

[7] Rana, Jitendra Rajendra and Pawar, Sunil N., Zigbee Based Home Automation (April 10, 2010). Available at SSRN: <http://ssrn.com/abstract=1587245> or <http://dx.doi.org/10.2139/ssrn.1587245>.

[8] Pradeep.G, B.Santhi Chandra, M.Venkateswarao, "Ad-Hoc Low Powered 802.15.1 Protocol Based Automation System for Residence using Mobile Devices", Dept.of ECE, K L University, Vijayawada, Andhra Pradesh, India IJCST Vol. 2, SP 1, December 2011.

[9] Amul Jadhav, S. Anand, Nilesh Dhangare, K.S. Wagh "Universal Mobile Application Development (UMAD) On Home Automation" Marathwada Mitra Mandal's Institute of Technology, University of Pune, India Network and Complex Systems ISSN 2224-610X (Paper) ISSN 2225-0603 (Online) Vol 2, No.2, 2012.

[10] Joice, C.S., Paranjothi, S.R. and Kumar, V.J.S., 2013, 'Digital Control Strategy for Four Quadrant Operation of Three Phase BLDC Motor With Load Variations' IEEE Transactions on Industrial Informatics, Vol. 9, No. 2, pp 974 – 982.

[11] Prashansa B, Prashant Kumar Strategy for Four Quadrant Operation Of DC Motor Using DSPIC30F4011"International Journal Of Recent Technology&Enginnering (IJRTE) ISSN;2277-3878,vol.3 Issue-3 july 2014.pp 73-76

BIOGRAPHIES



G JYOTHI KIRAN Pursuing B.Tech in Electrical & Electronics Engineering in Pragati Engineering College. His Area of Interest in Electrical Machines & Electrical Circuits.



K SATYA SURENDRA Pursuing B.Tech in Electrical & Electronics Engineering in Pragati Engineering College. His Area of Interest in Electrical Machines.



S A MOHIDDIN Pursuing B.Tech in Electrical & Electronics Engineering in Pragati Engineering College. His Area of Interest in Electrical Machines.



M KRISHNA Pursuing B.Tech in Electrical & Electronics Engineering in Pragati Engineering College. His Area of Interest In Power Systems.



S SANTHOSH KUMAR Pursuing B.Tech in Electrical & Electronics Engineering in Pragati Engineering College. His Area of Interest in Power Electronics.