

# Fire Detection Based on Color, Shape and Motion

Monika Waghmare<sup>1</sup>, Prof. Meenakshi Annamalai<sup>2</sup>

<sup>1</sup>Department Of Electronics & Telecommunication , JSPM's Bhivarabai Sawant Institute of Technology and Research, Wagholi Pune, Maharashtra, India

<sup>2</sup> Professor, Department Of Electronics & Telecommunication, JSPM's Bhivarabai Sawant Institute of Technology and Research, Wagholi ,Pune, Maharashtra, India

\*\*\*

**Abstract** - It is method which is able to detect fires by analyzing the videos acquired by cameras . It is the computer vision based fire detection algorithm. Works on continuous frames of images are captured by camera. Thus it has faster response time. These images are monitored by software. After that, fire detection algorithms are applied on the video such as color blurring, RGB to HSV conversion using matlab .

**Key Words:** Camera, MicrocontrollerLPC2148, PC,GSM module, Buzzer, LCD-Display, USB to serial converter.

## 1.INTRODUCTION

Nowadays different types of fire and smoke detectors are existing in the market. Smoke detectors are used to detect smoke which tells that fire is existing. Several methods have been proposed, used to analyze the videos acquired by traditional video surveillance cameras and detect fires or smoke. There are two main types depending on the analyzed features: color based and motion based and based on the consideration that a flame. In many proposed method, only physical devices like temperature sensor, smoke sensor are used to detect fire. But sometimes it gives false alarms. Hence the computer vision based fire detection algorithm is needed. This technique is used along with conventional fire detection method. In this we study, continuous frames of images are captured by camera. Thus it has faster response time. These images are monitored by software. After that, fire detection algorithms are applied on the video such as color blurring, RGB to HSV conversion using matlab .

The detection of fire by video is mostly appropriate in industrial monitoring and surveillance used to display buildings and environment as a part of an initial warning mechanism that gives message of start of fire. Video-based systems can sense fires at an early stage before tragedy.

Conventional fire detectors are costly and they are not suitable for open spaces such as forest . They highly produce false alarms and often detect fire when it's too late. So we have to design low cost fire detection system with small response time. Computer vision based techniques has a great capacity to meet these requirements. This detection

of fire in video is mostly used in industrial monitoring , buildings and in forest . Cameras can be attached everywhere freely, therefore detection range is larger. Technology has higher consistency and real-time performance.

## 2 METHODOLOGY

### 2.1 System Overview

The system gives the schematic design of fire detection system. Here we have two architectures. One is image processing technique and the other is hardware based conventional method. Here in this module the video of the fire is captured by collecting the sequential frames using camera. We have analyzed the images which consist of fire or smoke samples. These frames of images are processed for detection of fire. This is done using various image processing algorithms. The software based result send to the microcontroller. Serial to USB converter is used as the interface between the PC and microcontroller. Here the SMS will be sending to the fire department through a GSM modem connected to the system using Attention commands. Any abnormality is detected then the microcontroller will turn on the buzzer. When detects fire switch on a water sprayer to spray water.

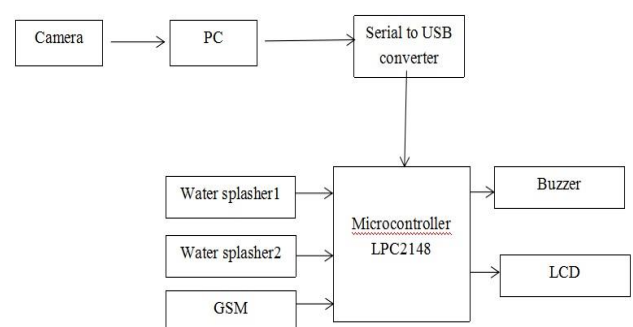

Fig1. Block Diagram of system

## 2.2 Image Processing

**Image Acquisition:** Image acquisition is first step in image preprocessing. Camera gives RGB data having 640 x 480 resolutions. Camera gives RGB images at the rate of 30 frames per second.

**Image Pre-processing:** After acquisition of image some pre-processing is done on acquired image. Preprocessing includes noise filtering using median filter.

**Noise Filtering:** Noises in the image will degrade the accuracy of image. In our project we are removing 'Paper and Salt Noise'. This noise can be removed by using Median Filter.

**Median Filtering:** Median filtering is used to reduce "salt and pepper" noise. The Median Filter replaces the central estimation of M-by-N neighborhood with its middle value.

Background is maintained and properly updated (Background updating) so it changes of the environments during the day; then, a background subtraction strategy is applied in order to obtain the foreground mask, encoding the objects moving in the scene (Foreground mask extraction). We get, the blobs, each one being associated to an object.

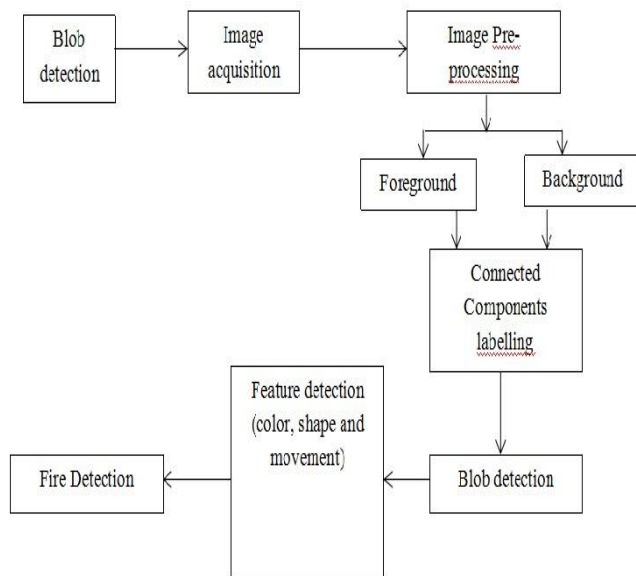

Fig.2. Image processing Part

## 3. IMPLEMENTATION

### 3.1 Hardware and Software used

- 1 Camera
- 2 Power supply 5v
- 3 ARM7
- 4 LCD display
- 5 USB to serial converter

- 6 GSM module
- 7 Matlab 2013a(software)

## 4.RESULT

### 4.1 Output using GUI

Using MATLAB coding we created GUI. We detect fire using camera and by connecting COM port to PC. We entered registered mobile number on which message would be sent in case of fire detection.



Fig -3: Snapshot of GUI

### 4.2 Output on LCD display and buzzer

Whenever fire is detected we will get message on LCD. Display that fire is detected and buzzer will start ringing.

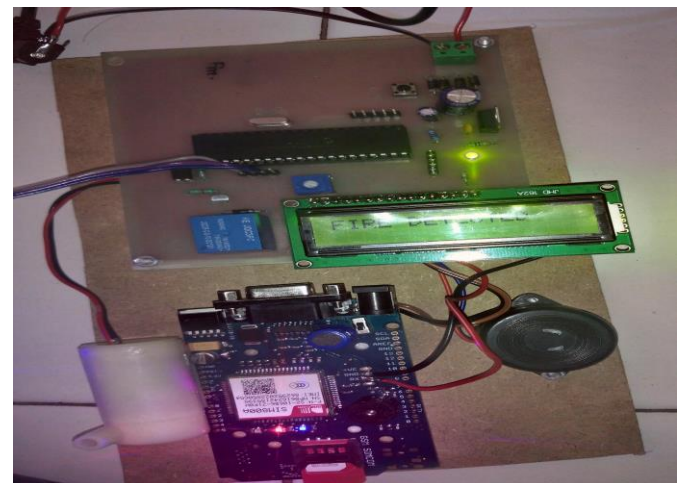

Fig -4: LCD display on circuit

## 5. CONCLUSIONS

This project discussed about a method which is able to detect fires by analyzing the videos acquired by

surveillance cameras. . Works on continuous frames of images are captured by camera. Thus it has faster response time. These images are monitored by software. After detecting fire we can manually send message to near by fire emergency services by GSM module. The advantage is that the overall performance of the system significantly increases as compared to traditional smoke detector.

## REFERENCES

- [1] MA Shu-guang Construction of Wireless Fire Alarm System Based on ZigBee Technology The 5th Conference on Performance-based Fire and Fire Protection Engineering2011 .
- [2] Jareerat Seebamrungsat , “ Fire detection in the buildings using image processing” Student Project Conference (ICT-ISPC), 2014 Third ICT International 26-27 March 2014 .
- [3] Kausik sen ET AL, “Automated Fire Detection and Controlling System” International Advanced Research Journal in Science, Engineering and Technology, May 2015.
- [4] Pasquale Foggia, Alessia Saggese, “Real-time Fire Detection for Video Surveillance Applications using a Combination of Experts based on Color, Shape and Motion” 2015.2392531, IEEE .