

# Development of IOS Application on Strengthening of Beams using FRP Composites

Ritesh L<sup>1</sup>, Mr. Manjunatha L<sup>2</sup>, Mr. Nisarg Shankar<sup>3</sup>

<sup>1</sup>PG Student, Department of Civil Engineering, SJB Institute of Technology, Bengaluru, Karnataka, India

<sup>2,3</sup>Assistant Professor, Department of Civil Engineering, SJB Institute of Technology, Bengaluru, Karnataka, India

\*\*\*

**Abstract** - In olden days, the large number of structures are constructed using older design codes all over the world and they are deficient to carry a loads as per new design codes. The maintenance of such structures is difficult and incurs a huge amount of public money and time. The rehabilitation and restoration of a structure is one of the most important things in civil Engineering field and also a very challenging thing is to select a strengthening method that will enhance the strength and serviceability of the structure. Hence the use of FRP composites is one of the strengthened method adopted in this work and this can be done by developing IOS application because as in present days use of application is increasing day to day and person to person. So keeping in that the development of IOS application is done and validated and used for the case study of residential building in which the beams were retrofitted for extra live loads.

**Key Words:** Retrofitting, Carbon Fibre Laminates, Flexural Strength, IOS Application, RC Beams.

## 1. INTRODUCTION

The reinforced concrete structure has very much important in these days. The solidness for this kind of structure has all the more relatively developed by utilizing other sort of materials. The upkeep is anything but difficult to sort of the structures. In a presently days, the rehabilitation and rebuilding of a structure is a standout amongst the most vital things in structural engineering field and furthermore an extremely difficult thing is to choose a fortifying technique that will improve the quality and serviceability of the structure.

### 1.1 Retrofitting

There is no single solution that offers a simple, straightforward method for all repair and strengthening projects. Further, the process of repair and retrofit of existing structures are complicated because most of these structures are occupied, and much of the mainstream construction community's expertise is centered on new construction. However, success can be achieved if repair and strengthening systems are tailored to serve a structure's intended use without interfering with its occupants or function. The key to success is a combination of different

design skills and application techniques, structural strengthening and structural repair necessary for such projects. As such, the Engineer must rely on his or her expertise in using mechanical and structural behavior principles to develop comprehensive retrofit solutions.

### 1.2 External strengthening by the usage of Fiber Reinforced Polymers (FRP) composites

As of late the civil designing field has begun to utilize FRP for structural support. This enhances a few extent such high quality weight proportion, high-firmness weight proportion, adaptability in plan, non-destructiveness. For the most part FRP materials are non-destructive, non-attractive and impervious to different sorts of chemicals they are progressively being utilized for outer support of existing concrete structural. This kind of utilization is normally alluded to as inside fortification. Also, carbon fiber fortified polymer (CFRP) strips can be utilized as outer fortification for expanding the load-conveying limit of ordinary steel and fortified concrete beams. In this kind of utilization, the CFRP strips are clung to the outside tensile face of a beam to supplement its flexural limit.

### 1.3 Growing importance of software application in daily life

The world is murmuring to the tune of portable applications where there is an answer for everything without exception with cell phones. The mechanical advancement by the different Mobile App Development Companies recommends that as an ever increasing number of individuals are getting dependent on versatile applications to satisfy such a variety of prerequisites while moving. Portable applications have in fact turned into a guide, a companion and an answer discoverer for individuals who are so occupied in their everyday lives. Apple appreciates an imposing business model and is places high on top of the interest for the Windows applications. It has likewise expanded throughout the years in light of the different new elements identified with social advertising, games and media news, informing administration and the new forms concentrating on the speed consider.

### 1.4 X-code and Swift Programming Language

Xcode is an incorporated improvement condition for macOS containing a suite of programming advancement instruments created by Apple for creating programming for macOS, iOS, watchOS and tvOS. To begin with discharged in 2003, the most recent stable discharge is rendition 2008 and is accessible by means of the Mac App Store for nothing out of pocket for macOS Sierra users. Swift is a universally useful, multi-worldview, gathered programming dialect created by Apple Inc. for iOS, macOS, watchOS, tvOS, and Linux. Swift is intended to work with Apple's Cocoa and Cocoa Touch structures and the expansive assortment of surviving Objective-C (ObjC) code composed for Apple items.

## 2. ANALYSIS OF STRUCTURE CONSIDERED

To study the flexural behavior of reinforced concrete beams with and without external strengthening by FRP wrapping as per ACI code and the analysis of residential building using ETABS for existing moment values of beams and also for the required live load moments for the strengthening of beams. To develop the IOS application on design of strengthening of flexural member the need of XCODE and SWIFT programming is used and also strengthening of existing beams for the additional loads using FRP composites by IOS application.

### 2.1 Analysis of structure

The modelling of the residential building is done using ETABS and analyzed for the static dead load, live load and earthquake loads. The project is residential building construction and situated at Haralur Bangalore. Here moderate exposure conditions are expected and fall in earth quake zone II. The safe bearing capacity of soil at depth of 1.5 m is taken as 200 kN/m<sup>2</sup>. The building consists of G+3 floors and this building required to build the swimming pool at the terrace floor. The building is analyzed without swimming pool and with swimming pool load to know the values of moments. By knowing the moment values the strengthening of beams is done.

Theoretical analysis and design check of the structural members of RC framing system is carried out using structural analysis software ETABS. As per the built structural framing plans and the dimensions obtained, the three dimensional analysis of the existing structure is carried out using structural analysis software.

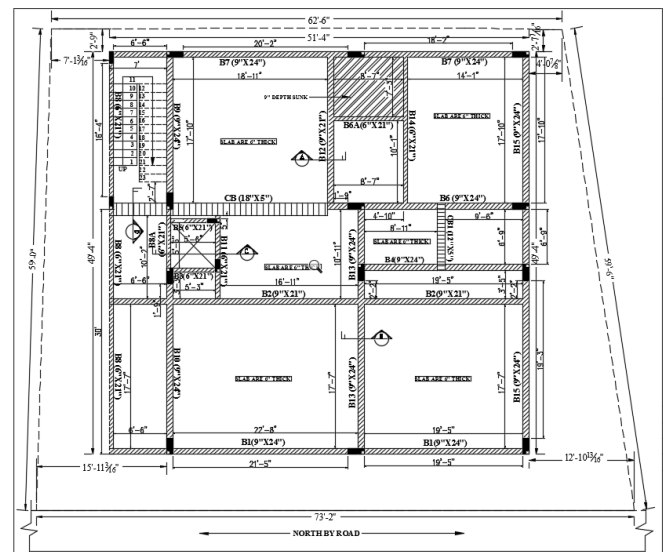

Fig 2.1 Beam layout of the plan

Table -2.1: Design codes and standards referred

IS: 875-1987 : Code of Practice for Design Loads	Part 1-Unit Weight of Building Materials Part 2 – Live loads
IS: 456 -2000: Code of Practice for plain and reinforced Concrete	
SP: 16 – 1980 : Design aids for Reinforced Concrete to IS:456-2000	
ACI 440-2r : Guide for the Design and Construction of Externally Bonded FRP Systems for Strengthening Concrete Structures	

### 2.2 Load and Load Cases

The dead load in a building shall comprise the weight of all walls, partitions, floors and roofs and shall include the weight of all other superimposed loads, which are permanently attached to the structure.

Self-Weight of slab is considered = 0.15 x 25 = 3.75 kN/m<sup>2</sup> (Considering 150mm thick slab)

Finishes = 1.5kN/m<sup>2</sup>

(Including suspending weights of AC ducts, pipelines, false ceiling etc)

In live load the following loads are considered,

Load on RCC slab = 2.0 kN/m<sup>2</sup>

Load on roof slab = 1.0 kN/m<sup>2</sup>

Live load on terrace floor containing swimming pool is

Height of the pool = 1.22 m

Density of water = 10 kN/m<sup>3</sup>  
 Total live load on slab = 1.22x10 = 12.2 kN/m<sup>2</sup>

In addition to gravity loads there are certain loads that are almost always applied horizontally, and these must often be considered in structural design. Such loads are called lateral loads. Some of the most important kinds of lateral loads are Wind loads, soil pressure, hydrostatic pressures, forces due to earthquakes, centrifugal forces, and longitudinal forces.

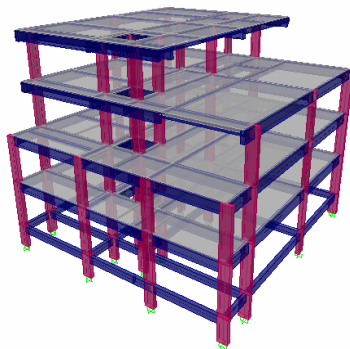

Fig 2.2 3D model of residential building

The model of with swimming pool and without swimming pool has been done and the values of bending moments and shear forces are compared. The model with failure of beams are taken and strengthened by using developed IOS application.

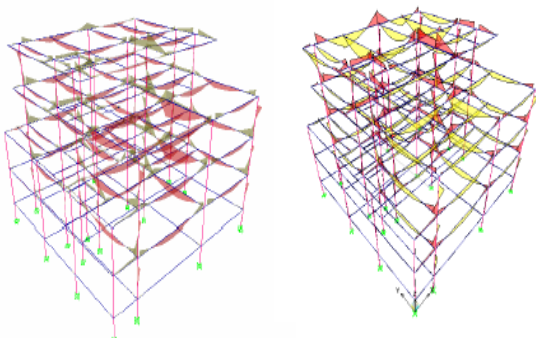

Fig 2.3 BMD of without and with swimming pool model

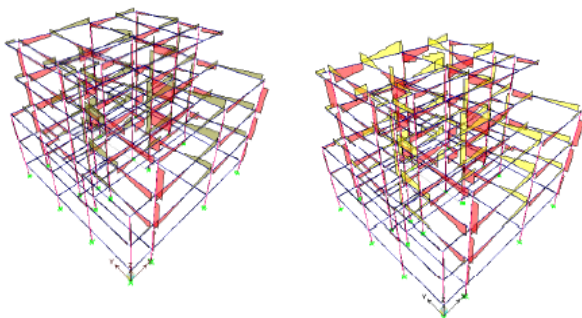

Fig 2.4 SFD of without and with swimming pool model

### 3. APP DEVELOPMENT

Development of IOS application using XCODE in OSX software and writing program on strengthening of beams by using FRP composites on SWIFT programming language.

To develop any program the flow chart is very important and it is step by step procedure to do the programming.

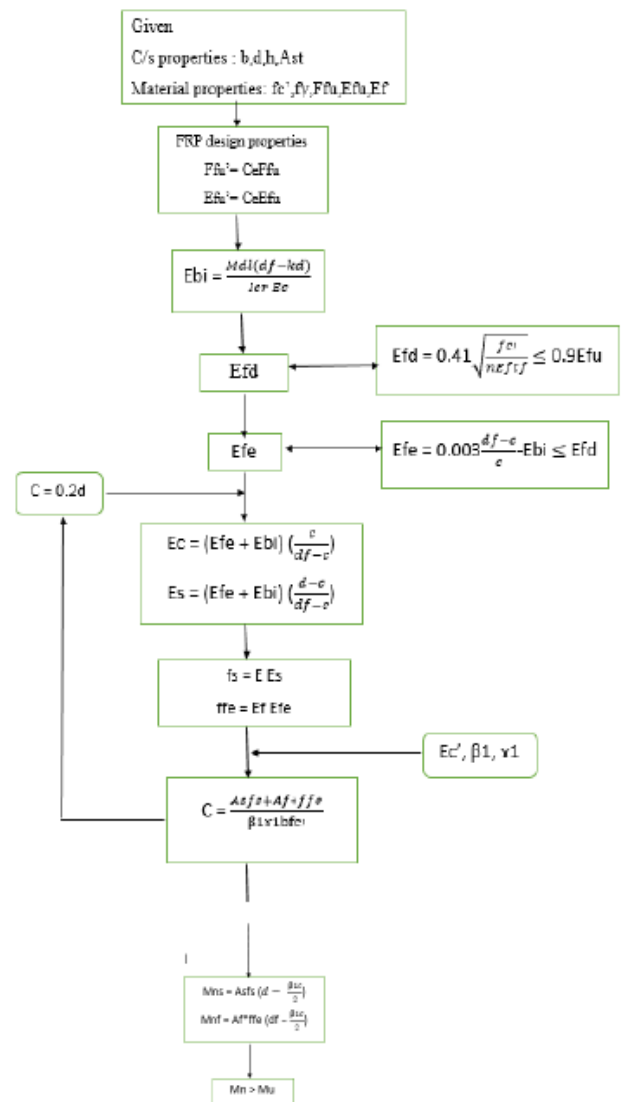

Fig 3.1 Flow chart of developed program

### 4. DEVELOPMENT OF IOS APPLICATION

The Graphical User Interface is the basic thing required for any of the application, with the help of the GUI the user can understand the working of the app. The GUI acts as the blue print for development of the application and also help-full for the developer for future up-gradation. The GUI can be done by knowing the step by step procedure for the design and that can be achieved by writing the flow-chart and

algorithm for the development, the flow-chart is described in the previous session and the GUI of the application is shown in the Fig 4.1

### 4.1 Building of application in X-code

X-code is the IOS application developer tool used in the Mac system for building of the application and act as a platform for the design and development of apps. X-code consists of swift programming language where program is done for the development of the app.

The steps in developing the application is

1. Creating new project in the X-code
2. Selecting particular story boards like launch screen, navigation controller and view controller for the particular gadget.
3. Designing the view controller screen by using the assistant tools like outlets, table views, images and buttons etc.
4. Writing program in the cocoa touch classes for the app and assigning to the particular view controllers.

### 4.2 Procedure

A. Initially the screen of the application is designed for the app and that can be done using view controllers of particular size and that screen should be disabled for auto layouts. Multi screens can be done using multiple view controllers and these screens can be attached by using the push segue.

B. The design of the view controller is done by using the assistant tools in the X-code, suppose if we need to input the data the outlets is used and for the naming text field is used similarly the image view can be used for the image update. After inputting the outlets the action can be done and this can be achieve by using the buttons.

C. After designing the view controller using assistant tools, the screen should be attached to the swift programming class called the cocoa touch class where the programming for the current screen can be done. Swift programming language consists of many data types, functions, variables, arrays, strings, and conditionals. By using these data types the programming can be done for the required application.

D. After all the design procedure the app is tested by one of the tool in the X-code called simulator and this simulator shows the application same as in the iphone and preview of the application can be seen.



Fig 4.1 GUI of developed screens

```

// ViewController.swift
// abc
//
// Created by Ritesh on 6/14/17.
// Copyright © 2017 Ritesh. All rights reserved.
//

import UIKit

class ViewController: UIViewController {

    override func viewDidLoad() {
        super.viewDidLoad()
        // Do any additional setup after loading the view.
    }

    override func didReceiveMemoryWarning() {
        super.didReceiveMemoryWarning()
        // Dispose of any resources that can be recreated.
    }

    /*
    // MARK: - Navigation

    // In a storyboard-based application, you will often want to do a little preparation before navigation
    override func prepareForSegue(segue: UIStoryboardSegue, sender: AnyObject?) {
        // Get the new view controller using segue.destinationViewController.
        // Pass the selected object to the new view controller.
    }
    */
}
    
```

Fig 4.2 Coca touch class in X-code

**5. USE OF DEVELOPED APP FOR STRENGTHENING OF STRUCTURAL MEMBERS.**

The residential building is analyzed with swimming pool model and without swimming pool model using ETABS. The bending moment of beams are compared and there is increase in the value of bending moments in the terrace floor of swimming pool model and 5 of them are deficient due to increase in live load and deficient beams were taken and strengthened by the developed application.

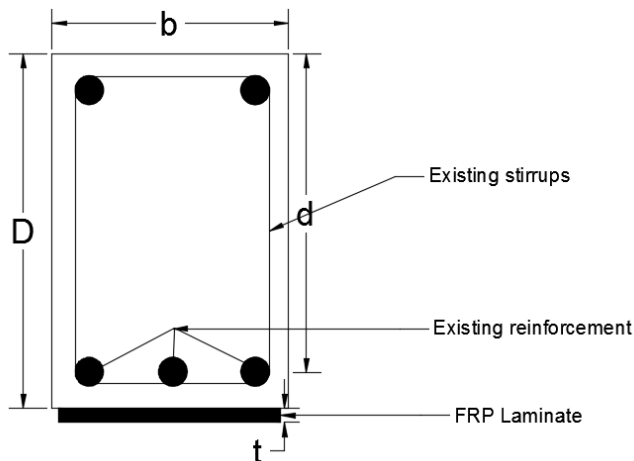

Fig 5.1 Cross section of beam (B35)

**Beam properties:**

- Breadth (b) = 230 mm
- Effective depth (d) = 585 mm
- Total depth (D) = 600 mm

**Material properties:**

- Thickness of FRP = 1.02 mm
- Ultimate tensile strength = 621 N/mm<sup>2</sup>
- Rupture strain = 0.0015
- Modulus of elasticity = 37000 N/mm<sup>2</sup>

Table 5.1 Beam and material properties

Beams	Beam properties	Material properties
B2, B3, B17, B37	b = 230 mm	Thickness = 1.02 mm
	D = 600 mm	Ultimate tensile strength = 621 N/mm <sup>2</sup>
	Fck = 25 N/mm <sup>2</sup>	Rupture strain = 0.0015
	Fy = 500 N/mm <sup>2</sup>	Modulus of elasticity = 37000 N/mm <sup>2</sup>
B35, B40	b = 200 mm	Thickness = 1.02 mm
	D = 450 mm	Ultimate tensile strength = 621 N/mm <sup>2</sup>
	Fck = 25 N/mm <sup>2</sup>	Rupture strain = 0.0015
	Fy = 500 N/mm <sup>2</sup>	Modulus of elasticity = 37000 N/mm <sup>2</sup>

Table 5.2 Design Summary of Strengthened beams by bonding FRP laminates

Beam	L m	As mm <sup>2</sup>	Mp kN-m	Mr kN-m	Af mm <sup>2</sup>	Mn kN-m	Remarks
B2, B3	6.3	902	123	290	470	303	Safe
B17, B37	6.2	904	108	230	470	300	Safe
B35	5.6	864	80	202	408	215	Safe
B40	5.6	943	93	254	408	230	Unsafe

**5.1 Strengthening of beam B40 by revising cross section followed by FRP wrapping**

From the above tables it is observed that 5 beams in the top floor of the building were unable to take extra live loads, hence those beams are strengthened by using developed

application. After strengthening of beams it is observed that beam (B40) has a flexural moment 230 kN-m which is less than required moment 254 kN-m and it is not safe.

The following procedure is used for the beam (B40) to sustain required moment.

Initially the beam properties of B40 and required moments were taken out and suitable additional cover concrete of 150 mm is provided by concrete.

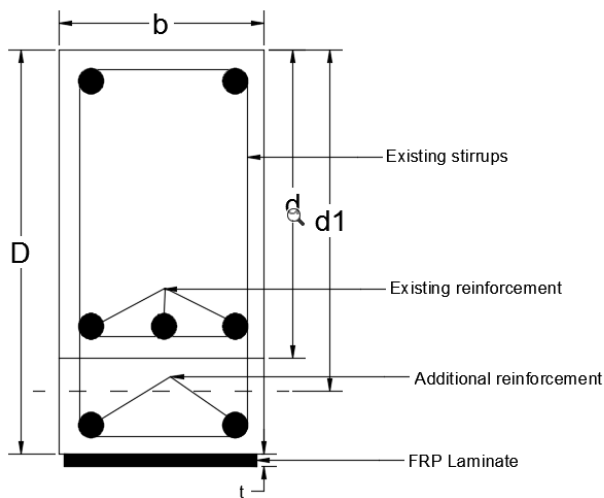

Fig 5.2 Revised cross section of beam (B40)

### Beam properties after concrete jacketing

Breadth = 200 mm  
 Initial depth ( $d$ ) = 450 mm  
 Extra depth ( $d_2$ ) = 150 mm  
 Effective depth ( $d_1$ ) = 545 mm  
 Total depth ( $D$ ) = 600 mm

### Material properties:

Thickness of FRP = 1.02 mm  
 Ultimate tensile strength = 621 N/mm<sup>2</sup>  
 Rupture strain = 0.0015  
 Modulus of elasticity = 37000 N/mm<sup>2</sup>

Area of FRP laminates required for the beam = 408 mm<sup>2</sup>  
 The flexural strength of the provided laminates = 332 kN-m  
 > 93 kN-m  
 Hence the section is capable of sustaining required bending moment = 254 kN-m

## 6. SUMMARY AND CONCLUSIONS

Based on the analysis and interpretation of results carried out in the work undertaken the following conclusion are drawn

1. Fibers elasticity plays an important role in increasing stiffness and this has led to decrease of deflection.
2. Several beams were found deficient and strengthened by developed application.
3. Strengthening of beams are done according to ACI 440 -2R code by bonding FRP.
4. To carry out the design calculations for strengthening of beams, an IOS application has been developed in swift code.
5. By using FRP as strengthening material the load carrying capacity of member increases.

6. The results obtained from developed application are comparable with the example problem given in ACI 440-2r and are reliable.
7. One of the beam in which the depth is low and bonding the FRP laminates is alone cannot be sufficient for strengthening, hence the depth of beam has been increased and followed by bonding FRP has been done.
8. With the use of IOS application the time taken for design calculations for strengthening is reduced. With the use of IOS application the complexity in design calculations for strengthening is reduced.

## REFERENCES

- [1] Habibur Rahman Sobuz, et al "Use of carbon fiber laminates for strengthening reinforced concrete beams in bending", IJCSE (2011) Volume-2, pp 67-84
- [2] K.B. Parikh, N.S Patel "Review on analytical study on strengthening of beam by FRP" IJRET, Volume 5, 2016, pp 11-14R.
- [3] N. Sundar at al "Flexural behavior of RC beams with hybrid FRP strengthening", IJCIET (2016), pp 427-433
- [4] Sandeep G et al "Strengthening of RCC beam using different glass fiber", IJES, V0lume 1, 2013, pp 1-8
- [5] T.H. Patel et al "Strengthening of RC beams with FRP sheets with different configurations in shear and flexure", IJETAE, Volume 6, 2016, pp 16-160
- [6] Building Code Requirements for Structural Concrete and Commentary (ACI 318m05)
- [7] Guide for the Design and Construction of Externally Bonded FRP Systems for Strengthening Concrete Structures (ACI 2r 08)