

Sensors Wield To Detect The Behavior Of Humans.

Avtansh Singh¹, Vandana Vikas Thakare²

¹Student, Dept. of Electronics and Communication Engineering, Madhav Institute Of Technology and Science, Gwalior, India ,

²Associate Professor, Dept. of Electronics and Communication Engineering, Madhav Institute Technology and Science ,Gwalior, India.

Abstract:- A decade years ago, a significant Research as well as investigation has been conducted in the area of real-time emotion recognition of a humans like Heart rate, Breathing rate, Body Temperature, skin conductance etc. Emotion recognition has a lot of applications in education, medicine, technologies and human-machine interaction. Actually, there are a various types of emotions i.e. stress, euphoria, angry, sentimental etc. On the basis of that a real time emotion detection device/sensors that are utilizes to detect the actual behavior of human i.e. heart rate and breathing rate and Body temperature in a different age groups, here is only three sensors are utilizes basically one for measure heart rate and other two utilizes to measure Body Temperature and irritating rate that are presented in the paper. The performance of the device is evaluated using experiments over to the subjects in a hospitals as well as normal society. In order to verify the feasibility of utilizing bio-signals to predict emotions all are working in a parallel as well as simultaneous. After measuring and performing certain process through Central Computing Unit it transmit to a present time advent technology and we call that smart phone via GSM module.

Key Words: Emotions, Sensors, Central Computing Unit, Smart phone ,GSM module (SIM900).

1.INTRODUCTION

With the advent of smart phones, continuous health care delivery has become easier. Today, there are several parameter-sensing platforms that use the mobile phone as a gateway (and display), and have the capability to directly alert the doctor or hospital in case of a problem with the health condition. There is a recent explosion of wearable devices, such as the Apple Watch, Samsung watch etc. there is a lot of gadgets in the markets which are collecting a superfluity of continuous vital signs, providing an opportunity to identify and prevent non-communicable diseases effectively. Autonomous systems that can provide quick and continuous health status monitoring of people are

surely desirable. It also improve personal health as well as lower health costs for society [1]. Such systems can monitor the certain parameters, like hear rate, the electrocardiogram (ECG) pulse, Subject irritation rate, body temperature eetc. at home as well in outdoor environments, keep the user informed about his health conditions and/or, alert medical doctors in case of emergencies. While continuous mobile health monitoring opens up new healthcare mechanisms, it also create challenges [2]. One of the most important challenges is to obtain relevant and meaningful health information from the continuous stream of vital signs, with the acquisition of the relevant signals from a sensory device. The present work represents a multi-parametric device that acquires important signs. It has a special purpose computer chip i.e AT89S52 that can continuously monitor, process and store the HEARTBEAT, BODY TEMPERATURE and IRRITATION RATE of a person[3]. The system consists of three sensors attached to a board for the subject, after gathering and processing all the information/behavior by a central computing unit. It transfer to a smart phone which are linked to a GSM module (SIM900). The device can be used simply to transmits the acquired data from subject to an automated /smart phone devices [4-5]. The contact number is dedicated to the particular doctor/hospital center. The present paper also presents an Embedded algorithms/coding over KEIL software that run on the device/controller to perform the certain task i.e. Body Temperature, \heart rate and irritating rate. On-device machine learning, to perform data fusion of the feature sets extracted from the different signals and combine them to estimate physical and emotional health.

2. PROPOSED PLATFORM ARHITECTURE AND METHODOLOGY.

Emotion is one of the very important part in human being. A million times ago emotions was a medium of communication. As the time passes with advent technologies devices are develop to detect above[17]. Variations in the biological signals shows emotions are rapid; hence, it is necessary to record the signals with higher accuracy rate. Psychologist

and Neuroscientists have different opinions about the generation of emotions [18-19]. The variations in the biological signals are generated by sympathetic nerves when a person is excited [20], and cannot be controlled by any person. In the present paper, a novel approach is proposed to detect the emotion of a subject. It utilizes sensors to identify heart rate, ECG, Body Temperature and a subjects irritations. The paper stressed to a device which determine the behavior/emotion of human. The presenting device is a demo of actual. In a certain condition a subject is recommended by a doctor for a permanent care. So at that situation a device is to be design which regularly monitors the subjects condition. In a certain interval it acknowledge a doctor or a care taker for the current behavior. If in a case subject is not in a normal i.e. heart rate, ECG, body temperature. In such condition an alert message sent to a particular number through a GPS module that are install to a device. A central computing unit also places for a continuous monitoring of a subject. According to the condition

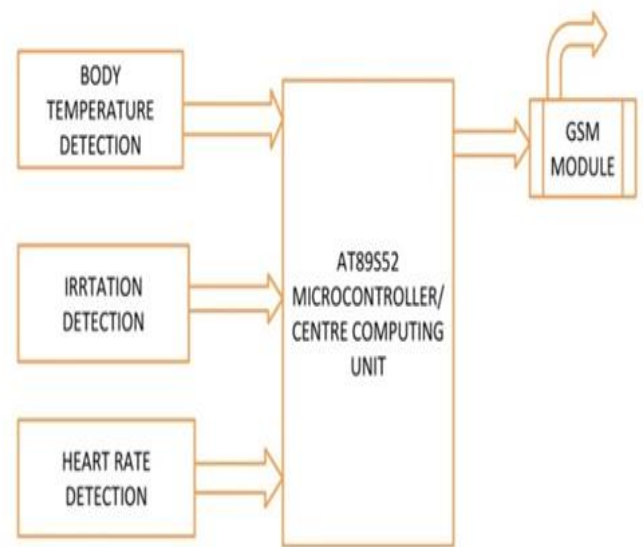

Fig.4 Architecture of a device.

the buzzer by pressing a button. After reset CCU monitor again. Buzzer will start acting for next threshold All the above monitoring system is designed over to the hardware and well programmed. The programming/command of controller is burned by a programmer and all the program is written over a keil software. An embedded C /Assembly and also reading of a patient i.e Heart rate taken from a hospital to compare the variations because heart beat sensor that i used giving an analog value so to get the exact variations in a different age group of a patient either male/female certain reading are taken from the clinics also.

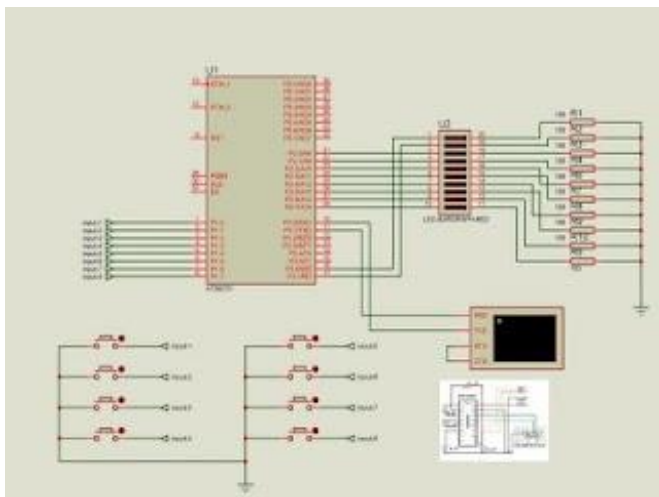

Fig.3 Design overview of Hardware over proteus

message is displayed to the LCD[21-22]. All the configure of device are shown above. After all the behavior monitored a controller having a limitations. In a device an alarm also integrated along with sensors for such limitations. Alarm functions is to show the subject need a proper medication right now. Alarm will buzzer continuously until the doctor or caretaker will not reach to a subject. It is necessary to reset

3. EXPERIMENTAL SETUP

In the Bio signal processing the discrete emotional model proposed by Ekman is widely used to detect basic emotions: joy, sadness, surprise, anger, love, fear. The model proposed by Ekman also claims that basic emotions are available in all cultures around the globe. The designed device is a simple demo of all the above situation. It monitors a subject condition that require a continuous monitoring. The proposed device utilizes sensors i.e. piezoelectric sensor, LDR sensors, IR LED and a thermistor. Piezoelectric sensor monitors the subjects irritating rate. LDR and IR LED is integrated in such a way to works as a hear beat sensors. While the Therrmistor is used for monitor the Body Temperature. All are assembled over the hardware with the application of embedded system. The proposed paper represents a controller which is specially programmed for a particular task.

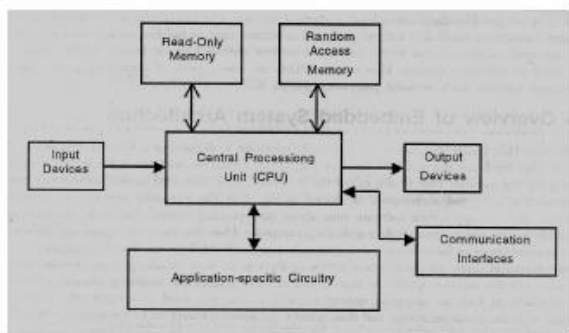

Fig.5 Embedded Hardware.

A number of approaches followed in systematic way to assemble all the above over a single hardware. According to the functionality of each and every sensor along with their accuracy. All are to be utilized in a proper pattern, so as to detect the performance of a subject. It generate an alert message to a caretaker. The proposed device command is programmed by Embedded as shown above figure. The command is burned to the controller by a programmer. Controller understand only hex file and are generated from the output window of a keil software. But the generated hex file must be successfully debug. Each and every program after debug generate five file and naming depending upon the program you may write over the keil i.e. C or in Assembly [20-21].



Fig.6 A programmer AND laptop.

When a program successfully debug then a programmer connected to a system. The subject participating in experiment touches both LDR and thermistor sensor. When irritating condition befall piezoelectric sensor will respond. All the required sensors as shown below. In the proposed research some of the record are taken from the hospitals i.e. ECG and also certain readings that are compared with the

previous experiment. There are various situation in the heart pumping, body temperature and irritating conditions.



Fig.7 Pizeoelectricsensor, Thermistor, LDR.and GSM Module.

4.RESULTS:

4.1 ECG Calculations.

After performing experiments with the help of doctors and cooperation of a subject a certain reading is to taken. All the obtained reading are compared with the normal reading of a subjects and some references i.e Dr.Bllams and Dr.Johnsons quotsons. The ECG abnormalities are detected by measuring and comparing P-R, QRS and Q-T intervals with normal values. Below the table is a normal reading of a human.

Table -4.1: Normal Range Of ECG.

Types of interval	Duration
P-R interval	0.12-0.2 seconds
QRS interval	Up to <0.1seconds
Q-T interval	Up to <0.38 seconds
R-R interval	0.6 to 1 (heart rate 60-100 bpm)

Variations of these readings represents variations in ECG .It is well known that the electrical conduction through the heart follows a certain pathway under normal conditions. When a disturbances in these pathways will alter the pathway of the wave of depolarization must follow and change the timing of the electrical events. Some of these disturbances will produce visually obvious effects as defined below: a physiological approach to the abnormal ECG, while others will produce such subtle changes that only calculation of the actual time involved will clue you in. In this section of the stressed paper cover the major calculations that will have to do in order to understand the ECG.

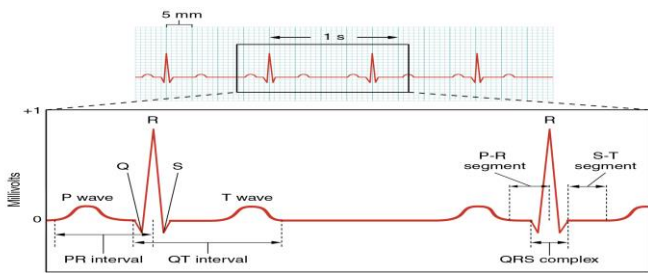

Fig.8 Reference for calculation Of ECG Wave.



The R-R interval: The RR interval is the time between QRS complexes. The instantaneous heart rate can be calculated from the time between any two QRS complexes. But the problem is that the calculated heart rate can be quite a bit different from the measured pulse. Due to variations in the heart rate associated with respiration (the sinus arrhythmia). Interval taken from I lead to aVR.

$$25\text{mm/sec} \times 0.4 = 1\text{beats/sec or } 60\text{ beats/sec.}$$

4.1 P-R interval

The PR interval is measured from the beginning of the P wave to the beginning of the QRS complex.



From the above graph 3 little squares between the beginning of the P wave and the beginning of the QRS complex shows as blue lines. The important piece of information that require to know is that each little square represent 0.04 sec i.e. (25 mm/sec, 1 sq = 1mm so 1 sq = 1 /25 = 0.04).

$$0.04\text{ sec} / \text{sq} \times 3\text{ squares} = 0.12\text{ sec} = \text{PR interval}$$

QRS interval: Similarly for QRS interval. 2 squares x 0.04 sec/square = 0.08 sec



The QT interval: In this segment total duration of the ventricular event, from when the first cell depolarizes to the last cell. There are many drugs which alter the QT segment and a number of congenital diseases in which the QT segment is prolonged have now been identified. The Long QT syndromes are associated with an increased death rate. The QT interval dependent on the heart rate, so it will often see the "QT", denoting that the printed interval.

$$\text{Number of squares}=12; 0.4 \times 12 = 0.48\text{ interval}$$

4.2 Temperature Variations.

The heart rate plays important role in body temperature variations. The heart rate is measured to detect Temperature control which is part of a homeostatic mechanism. In humans, the average internal temperature is 37.0 °C (98.6 °F), but it varies among individuals. However, no individual always has exactly the same temperature at every moment of the day. Temperatures cycle regularly varies up and down through out day. The lowest temperature occurs about two hours before the person normally wakes up as experiment taken over subject. Additionally, temperatures variations according to activities and external factors are also responsible for ups and downs. Below table shows normal temperature abnormal temperature of both Men and women after performing test.

Method	Women	Men
Oral	33.2–38.1 °C (91.8–100.6 °F)	35.7–37.7 °C (96.3–99.9 °F)
Rectal	36.8–37.1 °C (98.2–98.8 °F)	36.7–37.5 °C (98.1–99.5 °F)

Tympanic	35.7–37.5 °C (96.3–99.5 °F)	35.5–37.5 °C (95.9–99.5 °F)
Axillary	35.5–37.0 °C.	35.5–37.0 °C.

Table 4.2.1- Comparisons of Temperature In men And women.

4.2.1-Body Temperature readings along with facts obtained by testing and with consultation with doctors.

Hot

- a) 41 °C (105.8 °F) – (Medical emergency) – Fainting, vomiting, severe headache, dizziness, confusion, hallucinations, delirium and drowsiness can occur. There may also be palpitations and breathlessness.
- b) 40 °C (104.0 °F) – Fainting, dehydration, weakness, vomiting, headache, breathlessness and dizziness may occur as well as profuse sweating. Starts to be life-threatening.
- c) 39 °C (102.2 °F) – Severe sweating, flushed and red. Fast heart rate and breathlessness. There may be exhaustion accompanying this. Children and people with epilepsy may be very likely to get convulsions at this point.
- d) 38 °C (100.4 °F) – (this is classed as hyperthermia if not caused by a fever) Feeling hot, sweating, feeling thirsty, feeling very uncomfortable, slightly hungry. If this is caused by fever, there may also be chills.

Normal

- a) 36.5–37.5 °C (97.7–99.5 °F) is a typically reported range for normal body temperature

Cold

- a) 36 °C (97 °F) – Feeling cold, mild to moderate shivering (body temperature may drop this low during sleep). May be a normal body temperature.
- b) 35 °C (95 °F) – (Hypothermia is less than 35 °C (95 °F)) – Intense shivering, numbness and bluish/grayness of the skin. There is the possibility of heart irritability.
- c) 34 °C (93 °F) – Severe shivering, loss of movement of fingers, blueness and confusion. Some behavioral changes may take place.
- d) 33 °C (91 °F) – Moderate to severe confusion, sleepiness, depressed reflexes, progressive loss of shivering, slow heart beat, shallow breathing. Shivering may stop. Subject may be unresponsive to certain stimuli.

- e) 32 °C (90 °F) – (Medical emergency) Hallucinations, delirium, complete confusion, extreme sleepiness that is progressively becoming comatose. Shivering is absent (subject may even think they are hot).

4.3 Heart Rate variations.

The role of the heart is to pump blood around our body. Within the blood is oxygen and nutrients that are needed to produce energy. However, when a subject is in sleeping or doing exercise then in exercise subject need more energy, To get more energy subjects need more oxygen and nutrients, therefore subjects need to pump blood around the body faster. The body does this by increasing heart rate. Let us think about this in another way using numbers.

Table.4.3.1Normal and Abnormal Range Of Heart Rate(BPM).

Indication	BPM
Normal	60-100
Tachycardia	>100
Bradycardia	<60

The arrhythmias may be either tachycardia (for faster heartbeat i.e. more than 100 beats per minute or bradycardia (for very slower heartbeat i.e. less than 60 beats per minute). The patient body temperature is measured to determine fever , Hypothermia and hyperthermia. Table 4.3.1 shows the normal and abnormal ranges for above parameter[22-23]. The processed data of abnormal values can be stored separately for future purpose for health check up and follow up of that particular subjects. The following experimental data was collected from a group of subjects, both male and female,

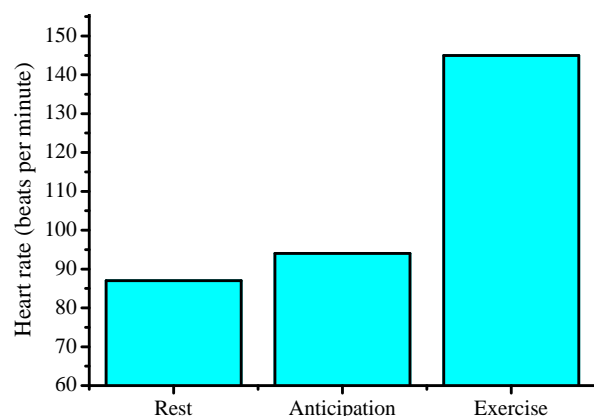

Fig.9- Histogram of Heart Rate in different condition.

4.3.1 Effect Of Exercise on Heart Rate.

During exercise heart beat varies. When performing some muscular task then we need more energy, for example running , legs need more energy. So body require more energy and to get more energy we need more oxygen and energy booster products thus heart pump blood around the body faster. The body does by increasing pump rate

As shown above histogram in a last column i.e. exercise

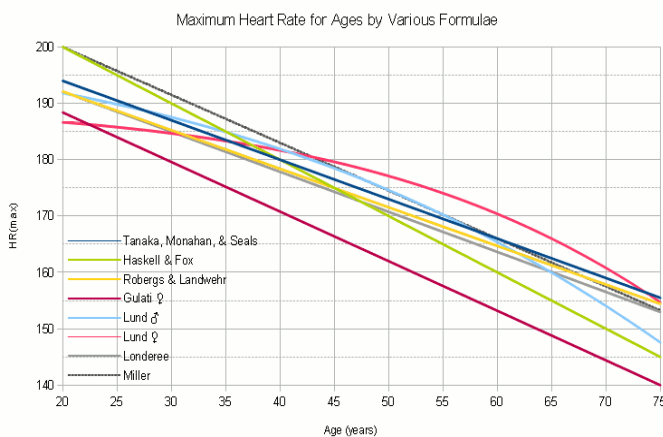

Fig.9: Heart rate In Different Age Group.

Above Graph represents Beats per minute in a different age group performed over number of subjects. Below table represents certain number of subjects under testing Heart rate in relax/rest condition .Below table two subjects having higher heart rate as compare to normal representing in bold format .

Table 4.3.2: Heart Beat in different age group

Name	HR(bpm)
A	82
B	84
C	98
D	112
E	97
F	93
G	91
H	87
I	112

5.DISCUSSION

Emotions generate variations in biological signals, and each emotion has its own characteristic manifestation. For example, when a person is angry, his/her heart rate rises and Body temperature rises while irritation also rises . At the same time, when the person is having fear, both the heart rate and the and body temp reduces but irritation will remain same i.e. high. Whereas , if a person has emotionally normal, the heart rate, and body temp is steady and feeling comfort.

6. CONCLUSION

A bio-signal based emotion detection device that utilizes heart rate and Body Temperature sensors and irritating behavior was presented. The performance of the device was evaluated using an experiment which had three subjects. It was observed that the average accuracy achieved for both “happiness” and “normal” emotions was around 83%, and both the emotions manifested same biological characteristics. Average accuracy of “fear” and “sadness” emotions was around 69%, while average accuracy for “anger” emotion was 85.33%. Some what accurate, and the feasibility of utilizing bio-signals from heart rate and body temperature sensors for emotion was studied.

REFERENCES:-

- [1] E. Jovanov, et al. , "Patient Monitoring Using Personal Area Networks of Wireless Intelligent Sensors," Biomedical Sciences Instrumentation, vol. 37, pp. 373-378 2001.
- [2] Apple Watch. Online: <https://www.apple.com/watch/>
- [3] Jawbone UP. Online: <https://jawbone.com/up/>
- [4] J. Parkka et al. 'Activity classification using realistic data from wearable sensors'. In: IEEE Transactions on Information Technology in Biomedicine 10.1 (2006), pp. 119-128. issn: 1089-7771.
- [5] Y. Hao and R. Foster. 'Wireless body sensor networks for health-monitoring applications'. In: Physiological Measurement 29.11 (Oct. 2008), R27.
- [6] F. Rincon et al. 'Development and Evaluation of Multilead Wavelet-Based ECG Delineation Algorithms for Embedded Wireless Sensor Nodes'. In: Information Technology in Biomedicine, IEEE Transactions on 15.6 (Nov. 2011), pp. 854-863.

- [7] G. H. M. Willemsen et al., "Ambulatory monitoring of the impedance cardiogram", *Psychophysiology*, 33: 184193, 1996.
- [8] CW Parott et al., "Comparison of Changes in Ejection Fraction to Changes in Impedance Cardiography Cardiac Index and Systolic Time Ratio", *Congest Heart Fail.* 10 (Suppl 2) 2004:11-13.
- [9] Nidal S.Kamel, Shohel Sayeed, and Grant A. Ellis, "Glove-Based Approach to Online Signature Verification", *IEEE Transactions on Pattern Analysis and Machine Intelligence*, Vol 30, No.6, June 2008.
- [10] Reinhard Gentner, and Joseph Classen "Development and evaluation of a low-cost sensor glove for assessment of human finger movements in neurophysiologic settings", *Journal of Neuroscience Methods*, 178(2009) 138-147.
- [11] Wireless Medium Access Control (MAC) and Physical Layer (PHY) Specifications for Low-Rate Wireless Personal Area Networks (WPANs) - IEEE Std 802.15.4™-2006 <http://www.ieee802.org/15/pub/TG4.html>
- [12] Y. Hovakeemian, K. Naik and A. Nayak, "A Survey on Dependability in Body Area Network," 5th International Symposium on Medical Information and Communication Technology, March 2011.
- [13] M. R. Yuce and J. Y. Khan, "Wireless Body Area Networks: Technology, Implementation and Applications", PAN Stanford Publishing, ISBN: 978-981-431-6712, 2011.
- [14] S. Chernbumroong, A.S. Atkins, and H. Yu, "Activity classification using a single wrist-worn accelerometer," in the 5th International Conference on Software, Knowledge Information, Industrial Management and Applications (SKIMA), pp.1-6, Sep. 2011.
- [15] D.M. Karantonis, M.R. Narayanan, M. Mathie, N.H. Lovell, and B.G. Celler, "Implementation of a real-time human movement classifier using a triaxial accelerometer for ambulatory monitoring," *IEEE transactions on information technology in biomedicine*, vol.10, no.1, pp.156-167, 2006.
- [16] R. Yousefi, M. Nourani, S. Ostadabbas, and I. Panahi, "A motion-tolerant adaptive algorithm for wearable photoplethysmographic biosensors," *IEEE journal of biomedical and health informatics*, vol.18, no.2, pp.670- 681, 2014.
- [17] "Motor Neurone Disease." *Motor Neurone Disease*. Web. 21 Jan. 2016.
- [18] P. Ekman. Basic emotions, pages 301–320. Sussex U.K.: John Wiley and Sons, Ltd, New York, 1999.
- [19] P. J. Lang, "The Emotion Probe: Studies of Motivation and Attention," *American Psychologist*, vol. 50, pp. 372-385, 1995.
- [20] Liu, Yisi, and O Sourina. "EEG-based Dominance Level Recognition for Emotion-Enabled Interaction." *2012 IEEE International Conference on Multimedia and Expo*, (2012): 1039-1044. (Conference Proceeding)
- [21] R. Yousefi, M. Nourani, S. Ostadabbas, and I. Panahi, "A motion-tolerant adaptive algorithm for wearable photoplethysmographic biosensors," *IEEE journal of biomedical and health informatics*, vol.18, no.2, pp.670- 681, 2014.
- [22] M. Chmelař, and R. Číž, "Problems of measuring pulse wave velocity," in *Proceedings of the 8th WSEAS International Conference on Circuits, systems, electronics, control & signal processing*, pp.320-323, Dec. 2009.
- [23] S.I. Lim, "Analog Front-End Circuit Design for Bio-Potential Measurement," *Journal of the Institute of Electronics and Information Engineers*, vol.50, no.11, pp.130-137, 2013.
- [24] D.O. Choi, and Y.J. Kang, "Development of u-Lifecare Monitoring System Device," *Journal of the Korea Institute of Information and Communication*
- [25] F. Rincon et al. 'Development and Evaluation of Multilead Wavelet-Based ECG Delineation Algorithms for Embedded and Wireless transmission Nodes
- [26] Rural Healthcare: Towards a Healthy Rural India, Gram Vaani. Ministry of Health & Family Welfare, Government of India , pp.1-4 , July 2015.
- [27] Madijagan Muthaiyan, Neha Goel, and Deepti Sunder Prakash , "Virtual E-Medic: A Cloud Based Medical Aid", *World Academy of Science, Engineering and Technology* 2012.
- [28] McKenzie, J.E.; Osgood, D.W. (2004). "Validation of a new telemetric core temperature monitor". *Journal of Thermal Biology*. 29 (7–8): 605. doi:10.1016/j.jtherbio.2004.08.020.