

Automatic Customer Counter and Payment Tool for Shopping Centers and commercial spaces

Said Ghaleb¹

¹Embedded Systems Student, Electrical Engineering Dept., Higher Institute of Technological Studies of Nabeul, University campus Mrezgua, Nabeul, Tunisia

Abstract - The number of visitors is a significant indication of success of every public or private commercial space. In those spaces many customers do not buy from their first visit and not all clients find their choice by just visiting.. We propose in this paper a smart customer counter for the shopping centers and commercial spaces. The system composed of three parts; the first part based on microcontroller PIC 16F88 to detect the visitors by the combination of two infrared barriers and infrared movement detector. The second part based on Arduino Nano and the XBee module used as an employe's badge. The third part consists of a PC and Windev GUI interface. The system collects the information of customer number and workers access then sends them to the PC via RF technology (XBee modules/ ZigBee protocol). The PC displays the data received using the graphic interface (GUI).

Key Words: PIC 16F88, infrared barriers, infrared temperature sensor, Arduino nano, XBee module, ZigBee protocol.

1. INTRODUCTION

In the private commercial sector, serve a numerous visitors (client/customers) per day is a profit index and reflects the performance of the workers, even the salaries of workers are relative to this performance. The continuous monitoring of visitor number during working hours is almost impossible by human beings, especially if the number of visitors is very important. We propose a smart system that control the access and count the passage through the entrance, eliminate the workers access, save the history of access through every gate, then sends it to the PC. A smart system that control and counts the access through the entrance (and exit gates if exist) can verify the number of visitors, save the history of access through every gate, then sends it to the PC. The data received by the PC will be saved in multi databases (visitor number database and workers databases); these databases will be used by the manager to determine the daily visitor number and the salary of every worker. The worker accessibility has no effect on of visitor number recorded, but it has an effect on their payments.

2. SYSTEM ARCHITECTURE

First of all, we will start with the global architecture of the system (figure1) to discover its different parts.

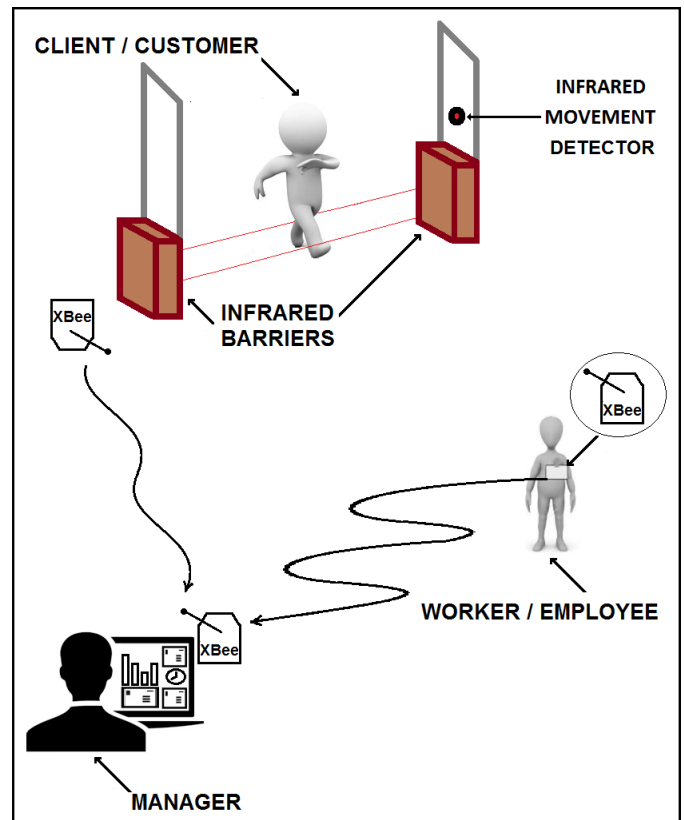

Fig -1: System architecture

The system function begins with customer detection. This detection may be realized by different methods; we can use an IR array as a people counter at the entrance of the building, but it's not an optimal solution because that can detect all objects and we can't recognize the direction of access [1]. In this paper the customer detection is done with the infrared barriers and a movement sensor. The direction of access (coming in or exit) is determined by the temporal order of interruption of the infrared beams. The movement detector checks whether the interruption due to a human being or an object, this checking up has been realized by a non-contact temperature sensor configured in the movement detector mode. After detection, the system checks whether all employees badges are connected to identify the detected person (client or employee) then the system update the client's number and the number of work hours done by employees.

3. SYSTEM DESIGN AND FLOW CHART

The system consists of three parts (as presented in figure2):

- 1) Hardware part:
This part is devised in two hardware parts
 - Access counter (clients counter): it's the main hardware part (presented with the red color in the bloc diagram figure2)
 - Workers electronic badge (presented with the yellow color in the bloc diagram figure2)
- 2) Telecommunication part:
This part consists of three common XBee modules between the two preceding parts presented with the three precedents colors in the block diagram) and the wireless RF signal (presented with the blue color in the block diagram figure2).
- 3) Software part:
This part consists of PC and graphic interface (presented with the orange color in the block diagram figure2).

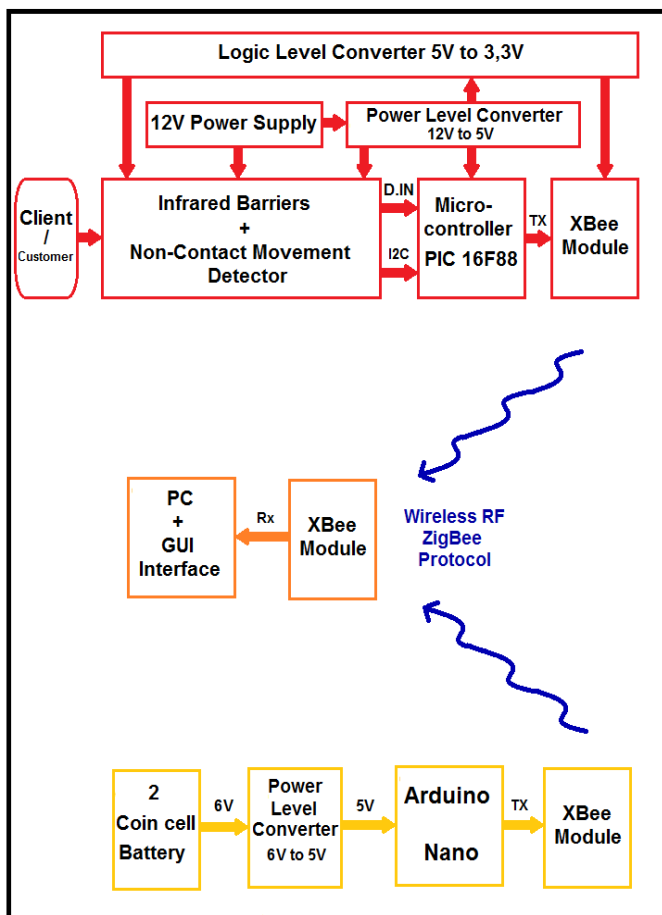

Fig -2: System block diagram

The main hardware part (clients counter) communicates with the software part through the Radio Frequency RF. The software part has to display the received data to determinate the visitors (client) number. To guarantee a right update of the workers' duty time, a real time communication realized between the electronic badge and the main hardware part. We can summarize the system functionality by the flow chart presented in figure3 below.

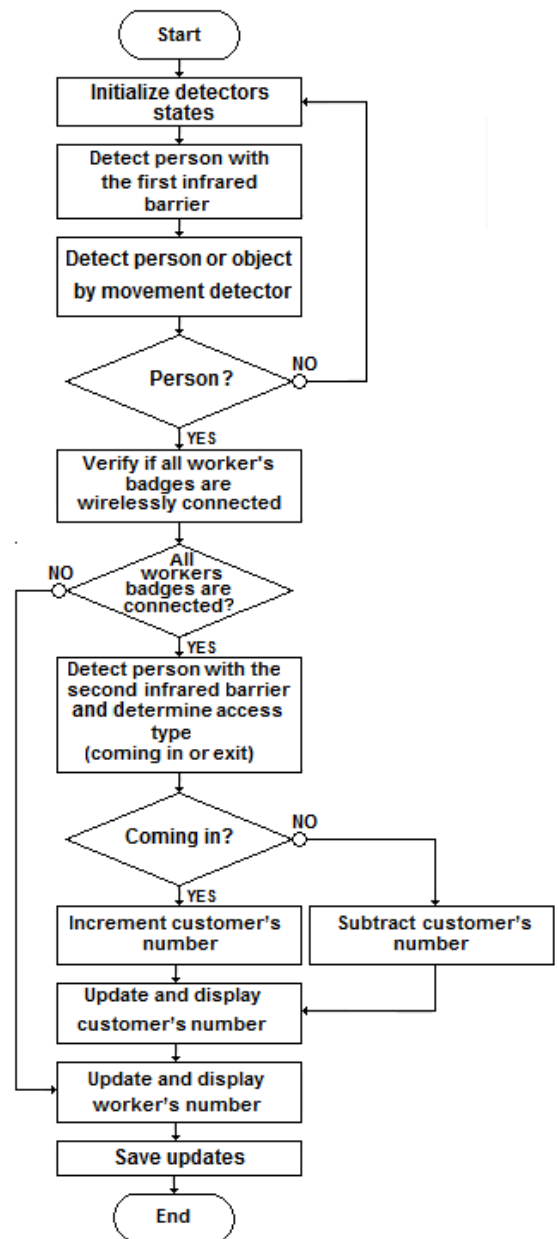

Fig -3 System flow chart

4. HARDWARE PART

The hardware part composed of many subsystems; start with the power supply system to the wireless communication part.

4.1 POWER SUPPLY

The clients counter need a multi-voltage levels; the infrared barriers need a 12V to function normally, the microcontroller operating voltage is 5V and the XBee modules need 3.3V as operating voltage. The optimal solution is to supply the whole system with 12VDC then shift it to the two others values. Next to the 12V we associate a 7805 regulator to have a steady 5V. The same method applied to the XBee module since it operates at 3.3V, but the voltage regulator switches to LM1117 adjustable output voltage IC[2]. The electronic badge power supply realized by two CR2032 batteries wired in series. At the output of these batteries we associate a 7805 regulator to have a regulated 5V voltage as the main PCB voltage. This type of regulator can convert an input up to 35V maximum into steady 5V[3]. The badge's XBee module operating voltage (3.3V) offered by the PIN number 17 of Arduino nano.

4.2 MOVEMENT DETECTOR

The movement detection was realized by the MLX90614, it's an infra-red non-contact sensor which is manufactured by Melexis can be used in multi-application as a high precision non-contact thermometer, windshield defogging, automotive blind angle detection and movement detection (presence detection). The sensor verifies the temperature in real time and can recognize the access of human being by their temperature range[4]. The sensor is interfaced with the I2C serial bus. The description of the sensor pins functionality is presented in figure 4.

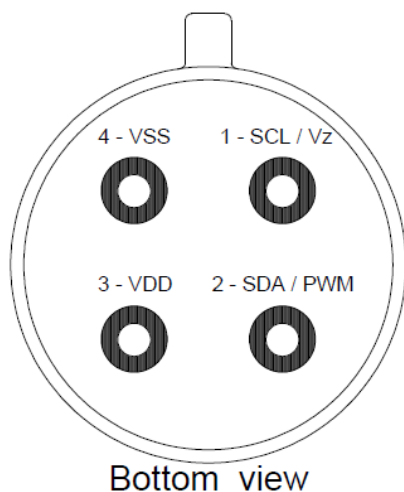

Fig -4 Pin description of the MLX90614[4]

4.3 INFRARED BARRIERS

The infrared barrier is a multi- infrared beam installed at the gate to detect access. In order to receive optimal functioning of the IR Barrier both the transmitter and receiver are to be adjusted precisely so that the core beam issued from the transmitter meets with the receiver[5]. In this study we use the commercial barrier GUARDALL SBT 30F which its main characteristics exposed on table 1.

Table -1: Technical characteristic of GUARDALL SBT 30F[6]

Technical characteristic of GUARDALL SBT 30F	
Operating voltage	11 V to 28 V DC
Consumption	65 mA
Infrared beams	2 beams
Detection	Simultaneous crossing of the 2 beams
Max range	35 m
Minimum installation height	0.30 m
Beam width at max range	0.90 m
Minimum distance (D) between 2 elements	0.90 m
Installation	Outdoor / indoor
Dimensions	196,5 X 82 X 73,5 mm

Since the detection achieved only when the two infrared beams was simultaneous interrupted. We used double successive barriers to determine the direction of access.

4.4 MICROCONTROLLER

The PIC16F88 Microcontroller used in this work is a Microchip microcontroller with a 7k instructions program, 256 bytes data references EEPROM, 368 bytes of RAM, two timers, and a 10-bit A/D converter microcontroller. It has UAR, I2C interfaces and can use oscillators for frequency up to 20 MHz. Its Operating voltage range from 2V to 5.5V, thus it is perfect to be used as an embedded system[7].

4.5 ELECTRONIC BADGE CONCEPTION

The electronic badge composed of two hardware components: Arduino nano and XBee module. The Arduino keeps the real time communication with the software part to verify if the employee still on duty. The XBee module is auto-powered through the Arduino nano 3.3V and GND PINS. The electronic badge ultimate prototype product was acceptable with a reduce dimension and a lightweight. The prototype PCB of the unpacked electronic badge exposed in figure 5.

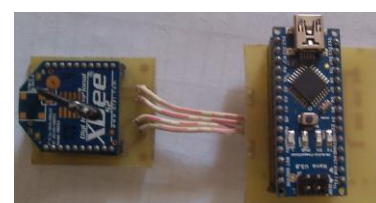

Fig -5 PCB of the electronic badge

4.6 MAIN SCHEMATIC AND PCB

We use the Proteus Professional software; ISIS and ARES to design both schematic and PCB layout. We could reduce the ultimate device in smaller by a good disposal of components and an optimal layout. The schematic of the main PCB is exposed in figure 6 and the circuit diagram and the prototype 3D model is respectively presented in figure 7 and figure 8.

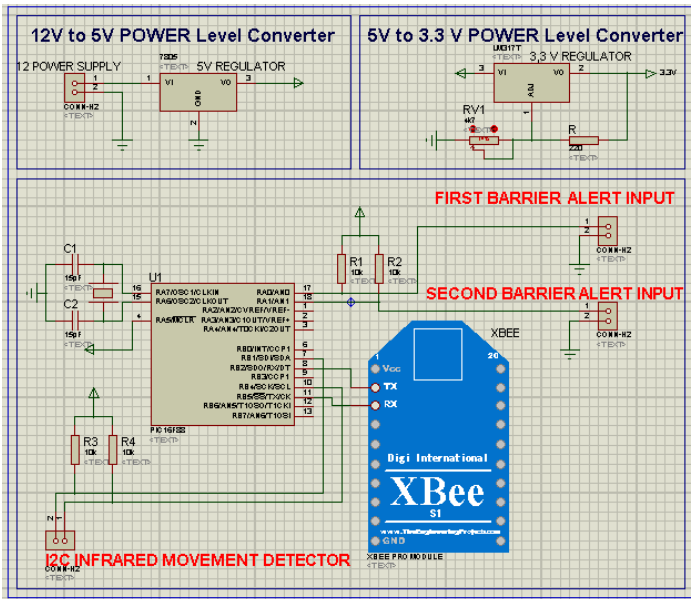

Fig -6 Main PCB schematic

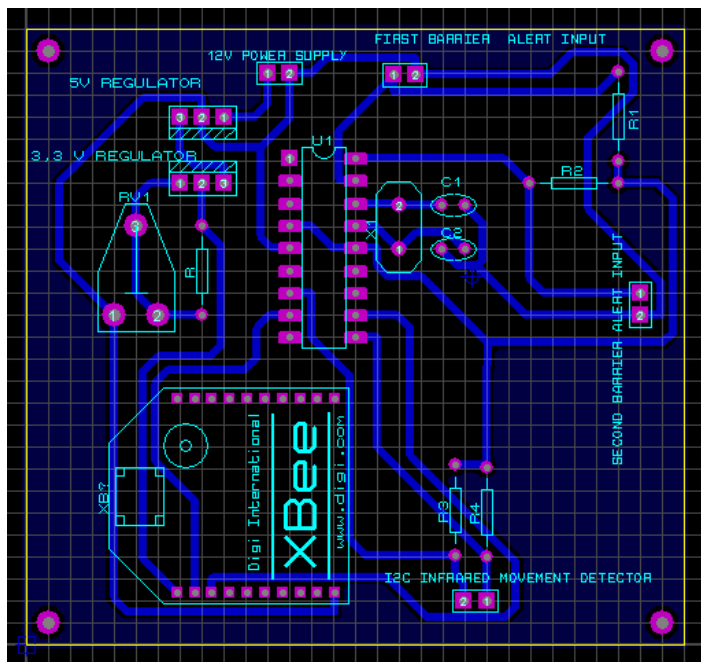

Fig -7 Main PCB circuit diagram

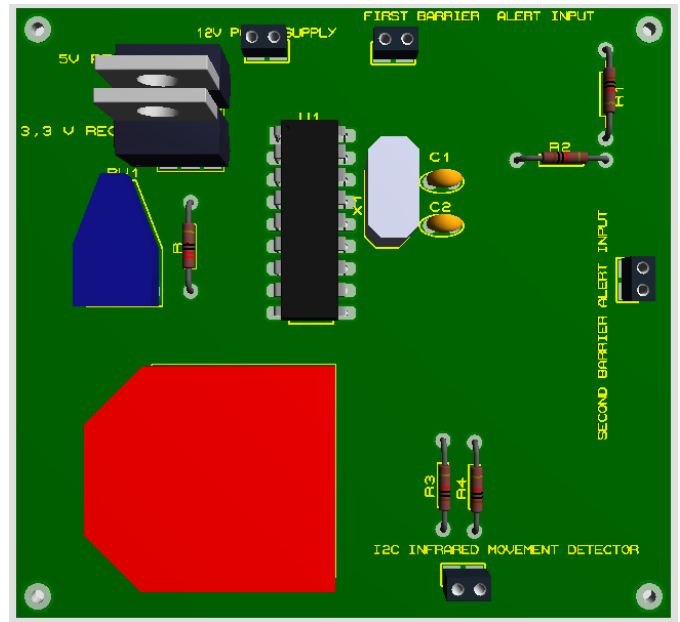

Fig -8 3D model of PCB prototype

5. TELECOMMUNICATION PART

The telecommunication part was realized by Xbee modules via ZigBee communication. The Xbee modules play the coordinator between the two parts, hardware and software through ZigBee protocol. The main duty of ZigBee is to transmit the wireless signal from the transmitter to the receiver. ZigBee, and Wi-Fi, which are corresponding to the IEEE 802.15.1, 802.15.3, 802.15.4, and 802.11a/bg standards, respectively. IEEE defines the physical (PHY) and MAC layers for wireless communications over an action range around 10-100 meters[8][9].

6. SOFTWARE PART

The software part receives the data via Xbee module through Xbee serial to USB adapter. It's the part responsible for saving the customer's number and employee data. This part is based on software interface installed on the manager's PC or laptop. The principal interface of the software presented in figure 9.

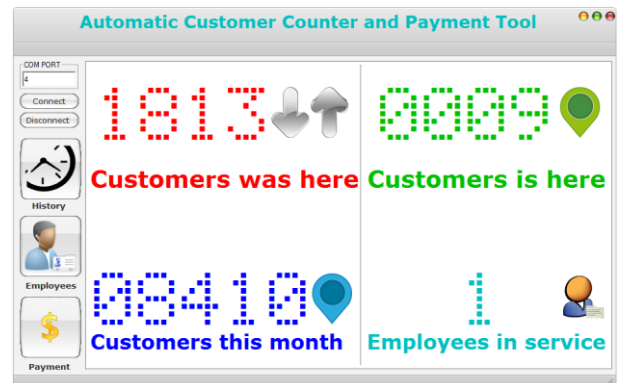

Fig -9 Main software Interface

The software interface displays the number of customers and save it with three modes:

- All customers of the day (presented by the red color in figure 9).
- Customers currently in the commercial space (presented by the green in figure 9).
- All customers of the month (presented by the blue color in figure 9).

Also the number of employees in service presented with the cyan color as shown in figure 9. The software also allow to review the history of all visitors (customers) and statistics every month, the software also permits to create, edit and expose employees profiles and calculate their salary.

7. OUTCOME RESULTS

After more than ten days testing this system in prominent scholar library, we get these results presented in Fig10.

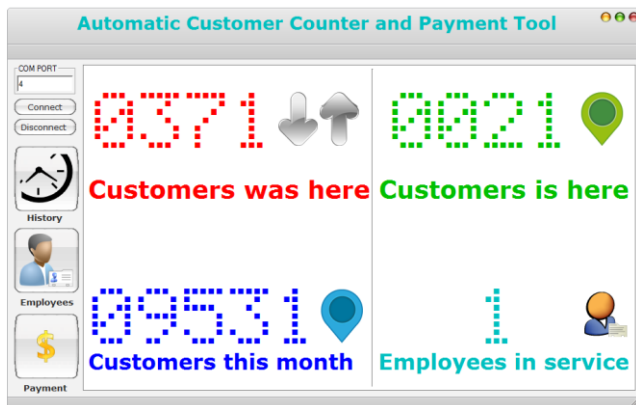

Fig -10 History of costumer window

The software displays the number of library’s customers with different modes (Customer of the day, Customers in and customer numbers of the current month...) as shown in figure 10. Moreover the history of currently month customers and all previous customers, the software permit to expose the statistic of current month as shown in figure 11.

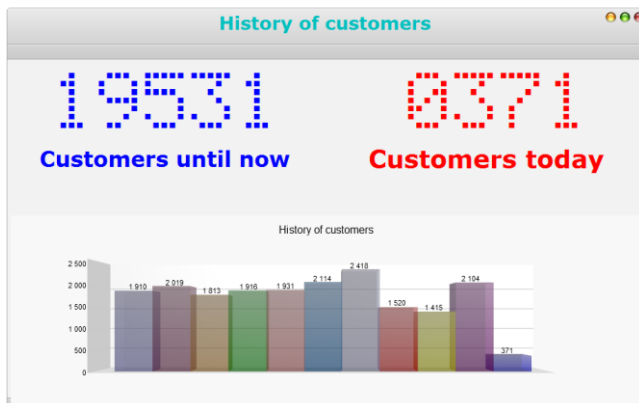

Fig -11 History and customers statistic

Furthermore, the software managed well the employees’ profiles, confirmed their presence or absence during service hours, and estimates their payment like shown in figure12 and figure 13.

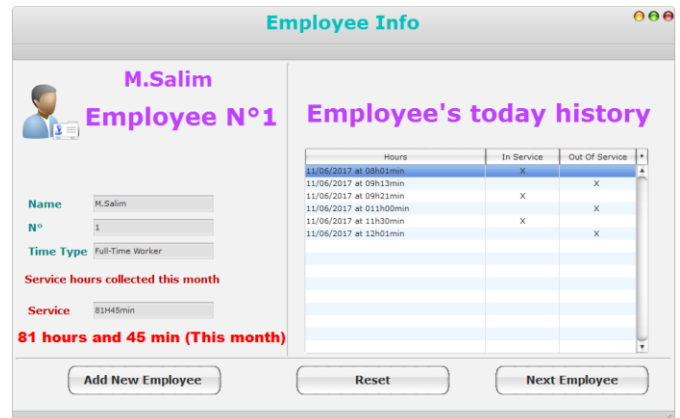

Fig -12 Employee info and presence

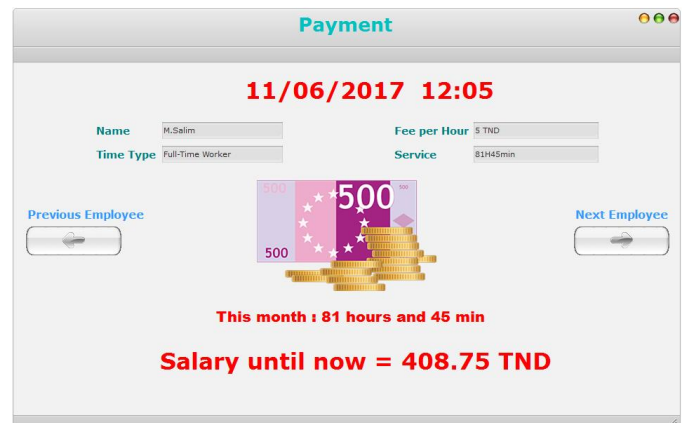

Fig -13 Employee salary window

The last day testing the system, we compared the automatic counting by a human being count for four hours and we get every fifteen-minute results presented in chart 1 below. To avoid any mistake the human counting was made twice (at the entrance and the exit of the customer) and we get 370 customers in total.

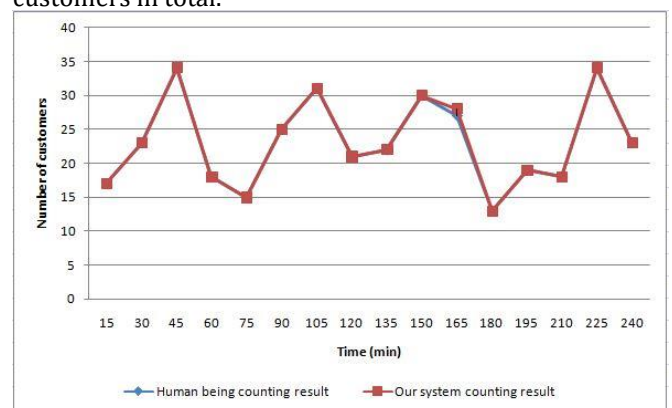

Chart -1: A comparative chart between the system's automatic counting and human being counts

The total of customers displayed by our system is 371; there is a slight difference as shown in the chart 1 at the minute 165 the system adds one customer. One customer per 370 (± 1 customer per 370) it's a difference of $\pm 0.27\%$, its small enough to be considered as a tolerance interval. Therefore, we can deduce that our system provides trustful and reliable counting results.

8. CONCLUSIONS

By the end of this study, the objective of this project has been achieved, the automatic customer counter and payment prototype has monitored the clients and employees efficiently without any perturbation or missing data. The employees access time and client number were well analyzed, transmitted, received, and displayed on PC screen. The whole system's components functioned so normally. Hence our system can be used as trusty customer counter and payment system without any doubt. As a future work the automatic customer counter and payment tool prototype can be modified to be smaller, able to detect customer's face. Therefore, we will integrate the main PCB in a FPGA or even integrate the circuit in a system on a chip (SoC).

REFERENCES

- [1] H. Ruser, "Object recognition with a smart low-cost active infrared sensor array," *Int. Conf. Sens. Technol.*, pp. 494-499, 2005.
- [2] Texas Instruments, "LM1117 800-mA Low-Dropout Linear Regulator," LM 1117 datasheet, no. 1, 2016.
- [3] Texas Instruments, " μ A7800 Series Positive-Voltage Regulators," LM7805 Datasheet, no. May, 2003.
- [4] Melexis, "MLX90614 Family Single and Dual Zone MLX90614 family," MLX90614 datasheet, pp. 1-51, 2015.
- [5] ARITECH, "Planning Instructions," *Act. Infrared Barriers Planning, Introd. Act. Infrared Technol.* August, vol. Edition 1, no. August, p. 5, 2000.
- [6] Guardall, "Barrières infrarouge actif double faisceaux Multi fréquences SBT 30F-60F-80F-100F-150F," *Install. Instr.*, vol. 1.5, no. 03042006 SAS, pp. 1-17.
- [7] Microchip, "PIC16F87/88," PIC16F87/88 Datasheet, 2005.
- [8] J. Lee, Y. Su, and C. Shen, "A Comparative Study of Wireless Protocols :," 33rd Annu. Conf. IEEE Ind. Electron. Soc., pp. 46-51, 2007.
- [9] A. Mapuskar, A. Kharade, K. Kedari, S. Shah, and K. Gaikwad, "Robot Controlled Using Hand Motion Recognition," *Int. Res. J. Eng. Technol.*, vol. 4, no. 4, pp. 424-427, 2017.

BIOGRAPHIES



Mr. SAID Ghaleb
Master Student in Embedded
Systems Dept of Electrical
Engineering
Higher Institute of Technological
Studies of Nabeul, Nabeul, Tunisia