

# Statistical Analysis of Wavelet Transform Based Features for Seizure Detection from EEG Signal

Geethu V<sup>1</sup>, Dr. Santhosh Kumar S<sup>2</sup>

<sup>1</sup>MTech scholar, Department of ECE, GECEI, Kerala, India

<sup>2</sup>Professor, Department of ECE, GECEI, Kerala, India

\*\*\*

**Abstract** -Abnormal electrical activity of a group of brain cells is known as seizure. Electroencephalogram (EEG) is most commonly used for the detection of seizure. This paper presents the study and analysis of statistical features for seizure detection from EEG signal. Discrete Wavelet Transform (DWT) is used for subband decomposition and from the selected subband features are extracted. Variance, standard deviation, maximum amplitude and skewness are the various features analyzed. There is significant difference in the feature values obtained from EEG database of patient and normal individual. Thus it is possible to detect seizure. The system is verified by Verilog in ISim simulator.

**Key Words:** Electroencephalography (EEG), Discrete Wavelet Transform (DWT), Feature Extraction, Seizure, Skewness, Variance, Standard Deviation

## 1.INTRODUCTION

Brain is one of the most important human organ that serves as the center of the nervous system for controlling the coordination of human muscles and nerves. Abnormal electrical activity of a group of brain cells is termed as seizure. Due to this seizure there may be temporary alternation in the brain functions which leads to a disease known as epilepsy. Around the world approximately 1% of the population suffers from epilepsy [1]. For 50% of people seizure can be eliminated by using antiepileptic medications. Thus exact seizure detection at exact time is essential. Electroencephalogram (EEG) which measures the electrical activities of the brain is very important in the diagnosis of seizure. Long term EEG recording is necessary in the case of infrequent epileptic seizure detection. The detection of seizure activity is therefore, a very demanding process that requires a detailed analysis of the entire EEG data. Detecting seizures that occur in daily life is important for the safety and well-being of those with seizures and those around them. But clinical systems are far too resource intensive for ambulatory settings. One of the many challenges in the automated detection of seizures is to distinguish between seizure activity and non-seizure activity. To accomplish this task, identification of the EEG features and there extraction plays a key role [2].

## 2. LITERATURE SURVEY

Hao Qu and Jean Gotman in 1997 proposed the First seizure warning system. It is a patient specific system and detects seizures similar to the template [3].

A new approach in features extraction for EEG signal detection was introduced by Carlos Guerrero-Mosquera and Angel Navia Vazquez. In this work features extraction was done using time-frequency distributions (TFDs). Three features included in the study are based on energy, frequency and the length of the principal track [4].

Adam Page *et.al* presented a low power, flexible, and multichannel electroencephalography (EEG) feature extractor and classifier for the purpose of personalized seizure detection. In this work the features include area under the wave, normalized decay, line length, average peak amplitude, and average valley amplitude [2].

Mohamed Bedeeuzzaman.V *et.al* presents a method for automatic seizure detection using higher order moments. In this higher order statistical features are calculated from each frame of predetermined length[5].

## 3. METHODOLOGY

EEG database of normal and seizure affected individuals are used. Before the feature extraction database is preprocessed. Features are extracted from the selected subband. The system can be simulated in Verilog ISim simulator. The method used can be summarized as the block diagram shown below.

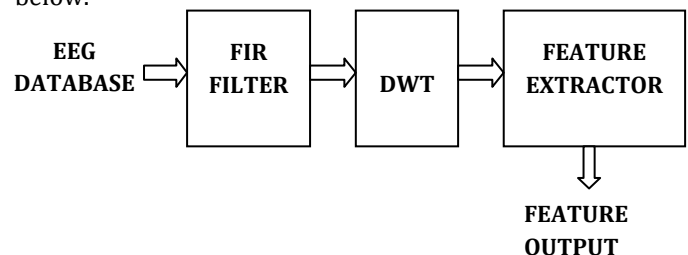

Fig -1: System Block Diagram

### 3.1 EEG Database

EEG database is given as input to the system. Publically available database from internet is used for this study [6],[7]. Five EEG database from normal and five from affected

individual is used. Sampling frequency of the data used is 256Hz. The Fig-2 shows a sample EEG database given to the system.

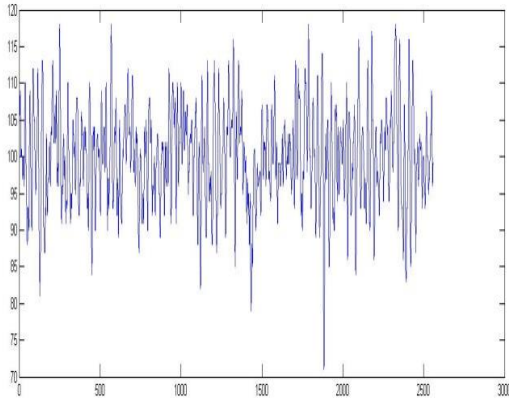

Fig -2: Sample EEG database input

### 3.2 Finite Impulse Response (FIR) Filter

FIR filter is used to remove the noise present in the EEG database. Electrocardiogram (ECG), Electrooculogram (EOG) and power line interference are examples of noise present in the EEG. Below Fig-3 shows the structure of FIR filter which consists of adder multiplier and delay elements.

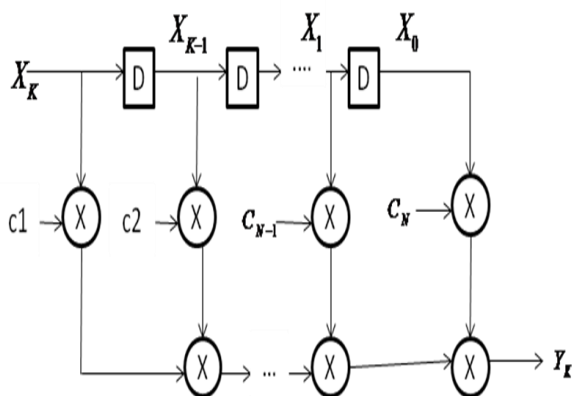

Fig -3: Structure of FIR filter

The output is given by the equation

$$Y_K = X_K C_1 + X_{K-1} C_2 + \dots + X_1 C_N$$

64 order FIR filter is used for this study. The filter is designed using FDA tool in MATLAB and the multiplier is realized using Baugh Wooley Multiplier. Baugh Wooley multiplier can be used efficiently for signed multiplication. Fig-4 shows the FIR filter design in MATLAB using FDA tool.

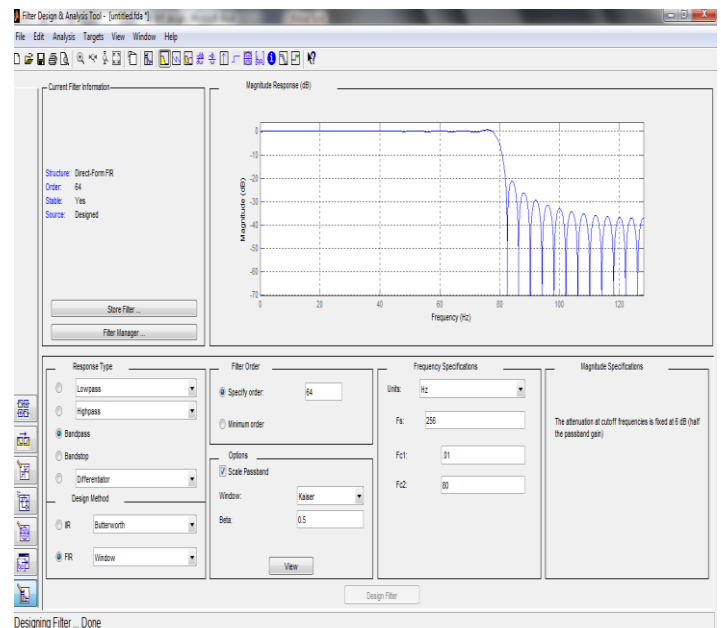

Fig -4: FIR filter design using MATLAB FDA tool

### 3.3 Discrete Wavelet Transform (DWT)

DWT is used for the decomposition of EEG signal into subbands. Delta (0.5 to 4Hz), theta (4 to 7 Hz), alpha (8 to 12 Hz) and beta (12 to 30 Hz) are the subbands in the brain waves. It is shown in Fig-5

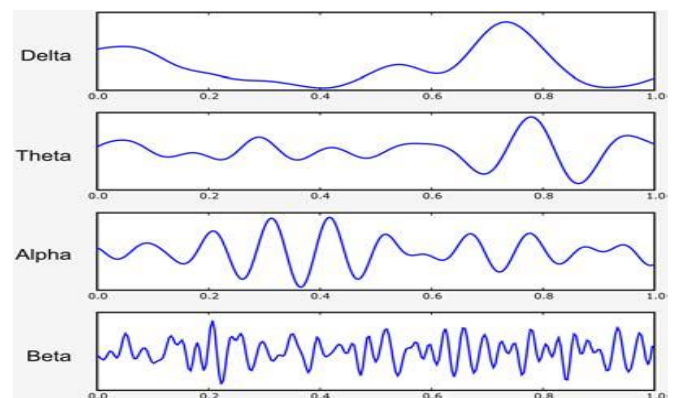

Fig -5: Brain Waves [8]

Since EEG signal is nonstationary in nature Fourier transform (FT) and Short Time Fourier Transform (STFT) are not suitable for subband decomposition. DWT consists of filter bank structure of low pass and high pass filters and down sampler by 2. Approximate and detailed coefficients are the down sampled output of low pass and high pass filters respectively. Approximate coefficient is decomposed in each stage to obtain next stage approximate and detailed coefficient. Fig-6 shows the four stage DWT. In the figure h(n) represents the low pass filter and g(n) represents the high pass filter.

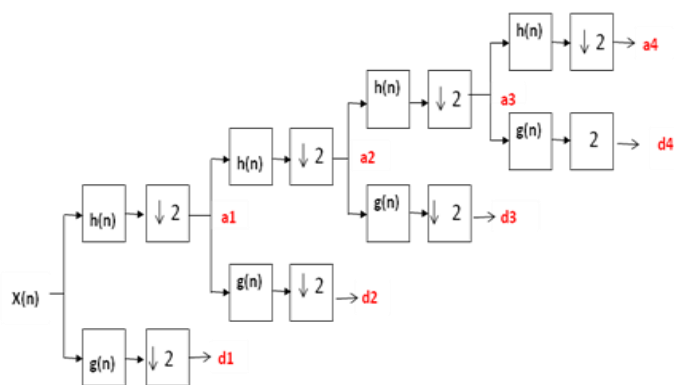

Fig -6: Four Stage DWT

Since the sampling frequency of the signal used is 256 Hz the fourth level detailed coefficient d4 is in the range of 8-16 Hz. This subband is used for feature extraction. Fig-7 shows the sample of fourth level detailed coefficient obtained from an EEG signal.

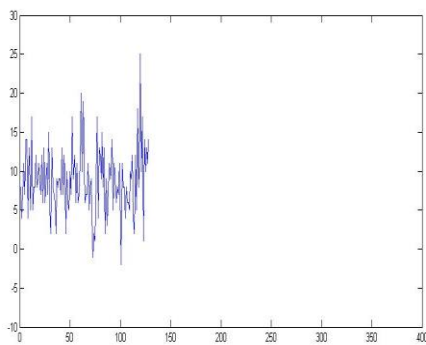

Fig -7: Sample of detailed coefficient at stage 4

### 3.4 Feature Extractor

The features variance, standard deviation, maximum amplitude and skewness are extracted from the selected subband. Five EEG database from the normal and five from the seizure affected individual is used in this study. The features are extracted from this 10 EEG database and analyzed.

#### 3.4.1 Variance

Variance is the measure of statistical dispersion of a random variable [5]. It is calculated by the equation

$$Variance = \frac{1}{N} \sum_{i=1}^N (X_i - \mu)^2$$

Where  $\mu$  is the mean of the signal

#### 3.4.2 Standard deviation (SD)

Dispersion of a set of data from its mean is measured by standard deviation. It is given by the equation

$$\sigma = \sqrt{\frac{1}{N} \sum_{i=1}^N (X_i - \mu)^2}$$

#### 3.4.3 Maximum amplitude

It gives the maximum value of amplitude in the data.

#### 3.4.4 Skewness

Skewness, the third order moment measures the symmetry or more precisely the lack of symmetry. It is given by the equation

$$Skewness = \frac{1}{N} \sum_{i=1}^N \left[ \frac{X_i - \mu}{\sigma} \right]^3$$

Where  $\mu$  is the mean of the signal and  $\sigma$  is the standard deviation of the signal.

## 4. RESULTS

By analyzing the feature values obtained it is seen that there is significant difference in the values of normal and seizure affected individual. Each of the feature values obtained from normal and patients are compared and the results obtained are represented as graphs shown below.

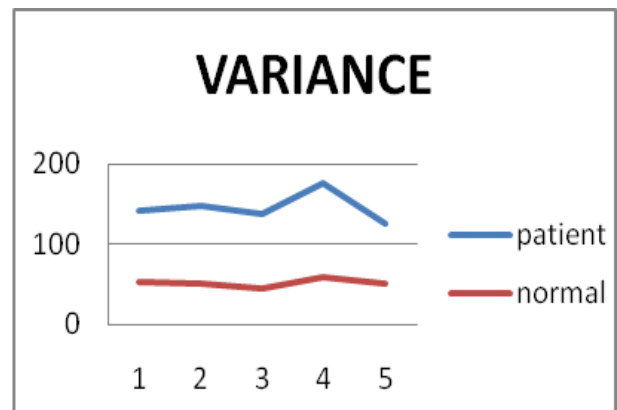

Chart -1: Analysis of Variance

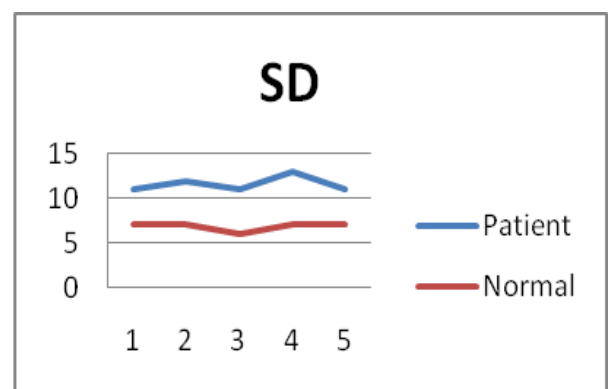

Chart -2: Analysis of Standard Deviation

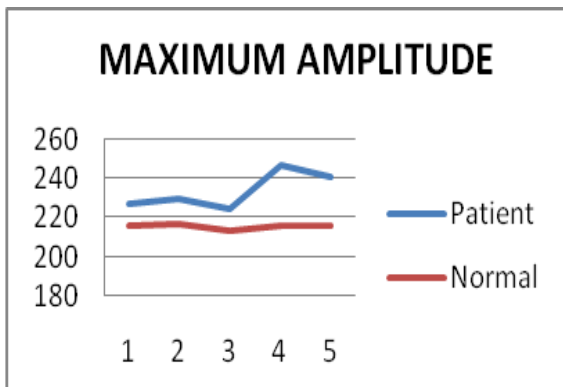

Chart -3: Analysis of Maximum Amplitude

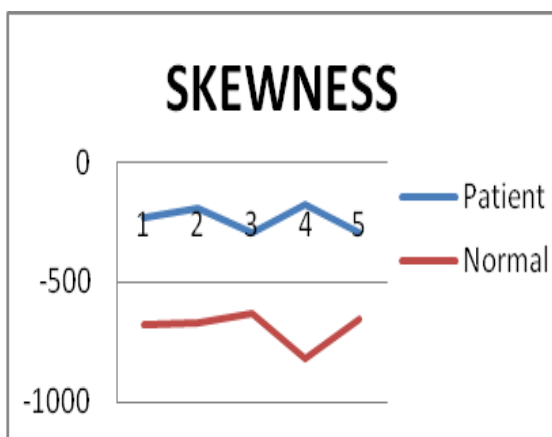

Chart 4: Analysis of Skewness

Simulation result of the system is shown in Fig-8.

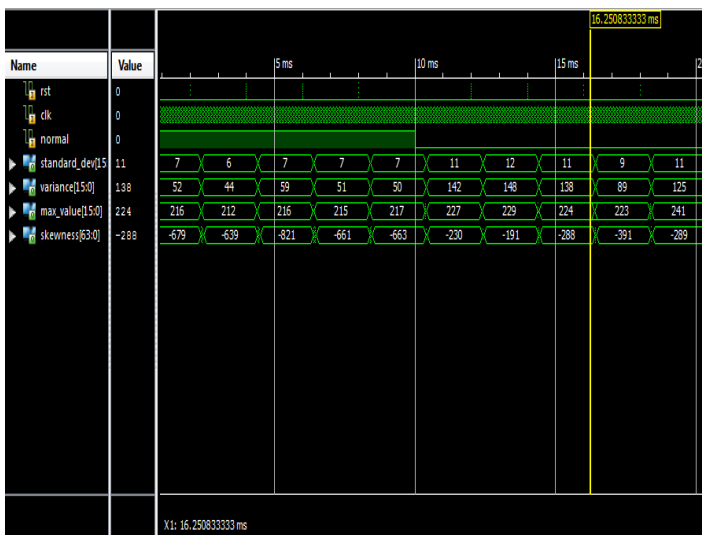

Fig-8: Simulation result of the system

When the signal normal=1 database of normal individual is given to the system and extracted the features from selected subband. When normal=0 EEG database of seizure affected

individual is given and obtained the features. It is shown in the simulation result.

### 5. CONCLUSIONS

Analyzed features variance, standard deviation, maximum amplitude and skewness of normal and seizure affected individuals from EEG signal. Before the feature extraction FIR filter is used to remove the noise from the signal and DWT is used to obtain the required subband. By analyzing the feature values obtained it is seen that there is significant difference in the values of normal and patient. The values obtained from the EEG database of normal and patient shows clear separation. Value of variance, standard deviation and maximum amplitude is higher in EEG signal of patient compared to normal. The variance value indicates that values are statistically dispersed more in EEG signal of patient. By comparing the values of standard deviation it can be seen that the data values are varied more in the EEG signal of patient. Skewness which measures the imbalance or asymmetry is higher in EEG signal of patient than in normal one. Because of this distinct nature of feature values for two classes it can be used for efficient seizure detection.

### REFERENCES

- [1] D. Alexandros T.Tzallas, Markos G.Tsipouras and Dimitrios I. Fotiadis, "Epileptic Seizure Detection in EEGs Using Time-Frequency Analysis", *IEEE transactions on information technology in biomedicine*, vol. 13, no. 5, September, 2009
- [2] Adam Page, Chris Sagedy, Emily Smith, Nasrin Attaran, Tim Oates and Tinoosh Mohsenin, "A Flexible Multichannel EEG Feature Extractor and Classifier for Seizure Detection", *IEEE Transactions On Circuits And Systems II: Express Briefs*, Vol. 62, no. 2, February, 2015
- [3] Hao Qu and Jean Gotman, "A Patient-Specific Algorithm for the Detection of Seizure Onset in Long-Term EEG Monitoring: Possible Use as a Warning Device", *IEEE transactions on biomedical engineering*, vol. 44, no. 2, February, 1997
- [4] Carlos Guerrero-Mosquera and Angel Navia Vazquez, "New approach in features extraction for EEG signal detection", *31st Annual International Conference of the IEEE EMBS Minneapolis, Minnesota, USA, September, 2009*
- [5] Mohamed Bedeuzzaman.V, Omar Farooq, Yusuf Uzzaman Khan, "Automatic Seizure Detection Using Higher Order Moments", *International Conference on Recent Trends in Information, Telecommunication and Computing*, 2010
- [6] [http://www.karunya.edu/research/EEGdatabase/public/view\\_all.php](http://www.karunya.edu/research/EEGdatabase/public/view_all.php)
- [7] <http://physionet.org/physiobank/database/chbmit>
- [8] <http://www.sleepwarrior.com/brain-waves-brain>