

“OPERATION OF SENSOR NODES FOR SMART FARMING AND DATA NETWORKING USING WIRELESS SENSOR NETWORK”

¹Priyanka A B, ²Vidya Honguntikar

Telecommunication Department, Dr. Ambedkar Institute of Technology, Bangalore, India

Abstract— Wireless Sensor Networks due to their enormous vicinity of appliance being worn in contemporary delve into areas. In farming turf resembling Greenhouses, various Climatic Condition Parameters are indispensable to monitored for instruction of reap fabrication. This paper is obtainable to formulate the computerization structure to mark out the confined climatic stipulation parameters (like CO₂, Temperature, and Humidity) at singular locations. Wireless Sensor Networks (WSN) does this occupation to mechanize and scrutinize the consequent parameters. The future scope is to develop the Web Application, Smartphone Application and Sensor Network by means of Zigbee Devices, Beagle Bone Controller and an assortment of Sensors. Wireless monitoring of turf not just allows client to condense the human supremacy, but it also allows user to perceive precise changes in it. It focuses on emergent devices and apparatus to deal with display and alert the users by means of the recompense of a wireless sensor network system. A smart structure based on meticulousness agriculture would overlay the line of attack to an innovative insurrection in agriculture. The client can scrutinize the agriculture atmosphere from a secluded location, thus providing a greenhouse condition for the vegetation.

Keywords —Arduino board, sensor nodes, sink node, soil moisture sensor, temperature sensor, humidity sensor, pump drivers, light sensor.

1. INTRODUCTION

Wireless Sensor Network (WSN) is nowadays used inboard locale of applications such as industrial monitoring, healthcare application, home automation and traffic control. The accomplishment of wireless sensor network does not only concentrate on the applications mentioned. Farmers can take advantage of the development of technology. Intellectual farming is now implemented to monitor the grade of the pasture environment. The parameters that are monitored in the greenhouse are temperature, relative humidity, light intensity and others that have effecting the quality of produce. One feature that affect the excellence of crops is the content of water in the soil, also called soil moisture. It is a foremost components of the soil comparative to plant growth. If the soil moisture is most advantageous for plant growth, plants can willingly suck up water. Irrigation schedule is considered necessary to meet the ever-increasing the insist of food. Soil moisture can be categorized based on the volumetric water content. This will

settle on the saturation on level of the soil. Contemporary intelligent agriculture uses wireless transmission. One crucial apprehension on wireless transmission is the power expenditure. The difficulty with other wireless transceiver like Zigbee and Bluetooth is the power consumption.

As the range of the transmission becomes longer, the element desires more power to transmit the data. Another deliberation is also the cost of the system. This equipment will apparatus a low power 2.4 GHz wireless transceiver for soil moisture monitoring and irrigation scheduling in agricultural greenhouse. The WSN is build of "nodes" - from a few to numerous hundreds or even thousands, where apiece node is associated to one (or sometimes several) sensors. The more modern networks are bi-directional, also enabling control of sensor activity. The development of wireless sensor networks was motivated by military applications such as battlefield surveillance; today such networks are used in many industrial and consumer applications, such as industrial process monitoring and control, machine health monitoring, and so on.

Each such sensor network node has typically several parts: a radio transceiver with an internal antenna or connection to an external antenna, a microcontroller, an electronic circuit for interfacing with the sensors and an energy source, usually a battery or an embedded form of energy harvesting. A sensor node might vary in size from that of a shoebox down to the size of a grain of dust, although functioning "motes" of unadulterated microscopic dimensions have yet to be produced .

2. Related Work

a. Agriculture Field Monitoring

Instead of observing the productivity and quality of faming all the time, this paper proposes the design to monitor the same attributes using wireless sensor network. For the growth, quality and productivity of crops in agriculture temperature, humidity and carbon dioxide levels are the most important climatic parameters. Moreover, when a critical change in one of the measurements occurs, then the farmer will be acknowledged via SMS and e-mail by an agriculture expert.

b. Environment Monitoring System

There are various problems in the traditional agriculture like weak real-time data acquisition, limitations in monitoring area, excessive manpower etc., The system collects various

climatic parameters like temperature, humidity, illumination, voltage etc. from greenhouse and from there it transmits the data to nearest server via GPRS. The system includes a web application which is using Google Maps to show the greenhouse status and provide regular voice and SMS alarm service. Since, it requires lots of power so it is powered by solar and storage batteries. This results that low power system has better scalability and can provide better service. [3]

c. Extending Automation to the Farm

Automation can be used to reduce amount of manual labor and make farming precise also leading to more agricultural growth. Number of operations of farm can be automated like irrigation system, temperature controlled system for livestock and farm product.[4]In this work they implemented automatic lighting system, automatic sprinkler system, house temperature control and security in farm houses. System is energy efficient because temperature and motion sensitive devices will work only when required. Energy efficient system is important factor for agro-based economy. [5]

d. Development of Precision Agriculture System

In this system temperature and moisture sensors are deployed at suitable location to monitor the crop. Sensing system uses feedback control mechanism with control unit which controls flow of water depending on temperature and moisture value. Control unit collects data from sensor analyze it and take action. [6] International Journal of Computer Applications (0975 – 8887) National Conference on Advances in Computing (NCAC 2015) 9

e. Irrigation Control by using WSN

Paper elaborates the application of WSN for Wireless Controlled and monitoring irrigation solution. The implemented irrigation method removes the somewhat need of farmer for flooding irrigation. In agricultural cropping system the efficient water management important factor.

f. Remote Wireless Automation and Monitoring of Large Farm

Application describes Designing and programming the controller to monitor and control the network using LabView Software. It shows changes in values of farm as well as real values required for controlling sensing sectors. RF link is built to connect farmer’s house and the sensing and control unit. Controller sends signal to farmer’s house from 10 KM.

g. Wireless Application of Drip Irrigation Automation

The crucial problem which is faced in agricultural areas is the irrigation by fresh water resources. The high demand of freshwater is highly increased, the optimal use of water resources has been provided by automation technology at a greater extent and its apparatus such as solar power sensors,

remote control and drip irrigation. There a difficulties on measuring & control systems over large geographical areas. The traditional instrumentations are based on discrete and connected network solution. The system was applied for drip irrigation of dwarf cherry trees on an area of 8 acres in the venue which is located in Central Anatolia.

3.Proposed model

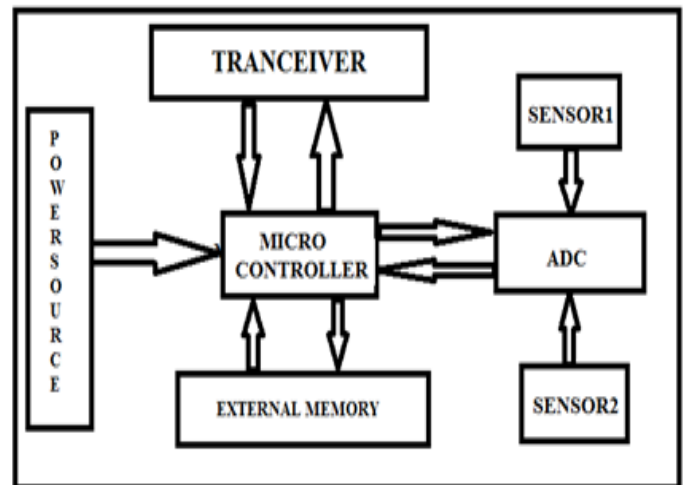

FIG 3:Block diagram of Sensor Node

The figure 3 shows the block diagram of sensor node includes components of sensor node data networking will place the main important role to transmit the data using wifi module we can find two main concepts with the both hardware and software simulation where in the hardware part with the several sensors nodes likes temperature, pressure and soil moisture sensor. The sensor nodes consisting of several parts namely transceiver, sensors with the ADC part PIC microcontroller, external memory and power resource. The few number of nodes are placed with the many of the components this transceiver part takes place in the physical layer in the OSI model. The many of the topologies are used since in this paper we will prefer Multihop and two hierarchical topology since it forms a clustered head where large number of nodes are connected the sink node this nodes has the capable connecting all the nodes to transmit the data to the observer part through the gateway which has the capable of converting Zigbee protocol which has IEEE standard of 802.15.4 gets converted into wifi module that is 802.11 with the internet access this can displayed in the terminal part of the observer. The important aspect of this WSN technology when the sensors

Will be in the analog form gets converted into digital form with the large number of nodes the data transmission is very easy.IOT concept place a vital role in implementing WSN technology since creating a network and connecting the embedded devices to the internet is an IOT the readings will be displayed in the terminal end of the observer.

4. IMPLIMENTATION OF SMART AGRICULTURE USING SENSOR NODE

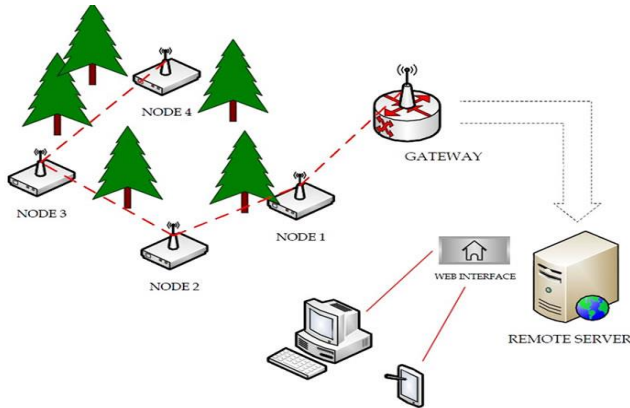

FIG 4: Proposed system of smart agriculture using WSN technology

The Figure 4 shows the performance of various nodes with the gateway wirelessly connected to the web server.

a. Sensing Node

The capacity of the sensor nodes is use to collect the information, processing the data and communicating with other networks. For every particular time interval the readings of the sensors then it forwarded o the routers. As in the case of Zigbee similarly Xbee protocols are used for the solar power as well as the storage batteries which is more configurable

b.Routers

A router is a networking device that forwards data packets between computer networks. Routers perform the traffic directing functions on the Internet. A data packet is typically forwarded from one router to another through the networks that constitute the internet work until it reaches its destination node. A router is connected to two or more data lines from different networks. When a data packet comes in on one of the lines, the router reads the address information in the packet to determine the ultimate destination. Then, using information in its routing table or routing policy, it directs the packet to the next network on its journey. This creates an overlay internetwork. Routers are the XBee devices which work independently, accept the various reading from sensor nodes and forward the values to coordinator. This is also capable to operate on solar power and storage batteries. Even though routers are optional part in the network because sensing node can directly send the values to coordinator / gateway.

c. Coordinator (Gateway)

In a communication network, a network node equipped for interfacing with another network that uses different protocols. Gateways, also called protocol converters, can operate at any network layer. The activities of a gateway are more complex than that of the router or switch as it communicates using more than

one protocol. Both the computers of Internet users and the computers that serve pages to users are host nodes, while the nodes that connect the networks in between are gateways. Coordinator is XBee device which accept values from various routers and sensing nodes.

d.Access points

Access points (also called base stations) provide wireless access to a wired Ethernet network. An access point plugs into a hub, switch, or wired router and sends out wireless signals. This enables computers and devices to connect to a wired network wirelessly.

e.Web server

Web server are the computers that delivers web pages. Every web server as an IP address and possibly an domain name.[3]

5.Working principle

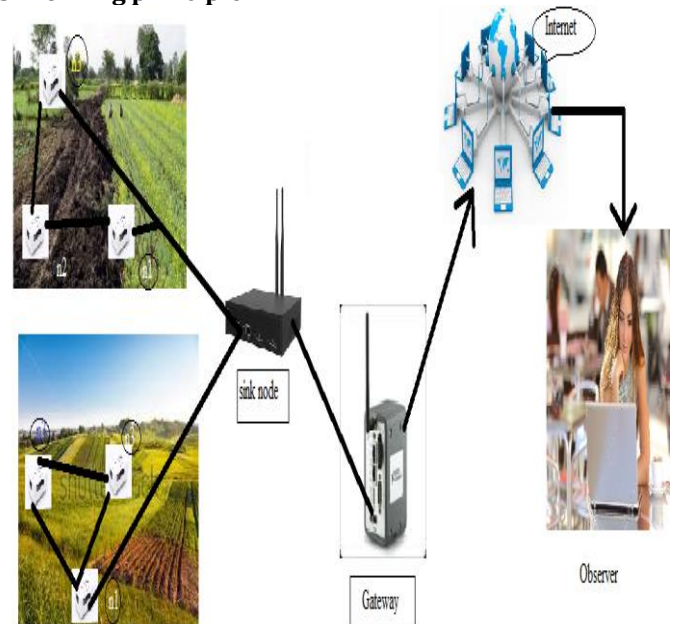

FIG 5:Working principle of smart farming using real time

The Figure 5 shows the overview of smart forming using WSN technology.WSN place a vital role in the agriculture field. As mentioned above soil temperature sensor, humidity sensor, atmospheric temperature sensor readings are taken in the plantation area if the value exceed beyond atmospheric temperature and pressure then certain WSN technology taken over their with pump drivers and motors. The values of these sensors can be displayed in LCD.Other way of getting a message is through GSM technology and getting a message for the observer then the observer can operate through IOT technology. Finally by using the motors and pump drivers the sprinkler or drip irrigation can be followed to get a good crop forming.

This web based technology has been developed to get the exact result to the observer through wifi module technology. we can WSN technology is trustworthy when we placed nodes between the gateway, when gateway will convert the zigbee protocol to wifi module i.e 802.15.11 gets converted into 802.11 IEEE standard and then the readings of all the sensors get displayed int terminal end of the system.

6.Flow chart

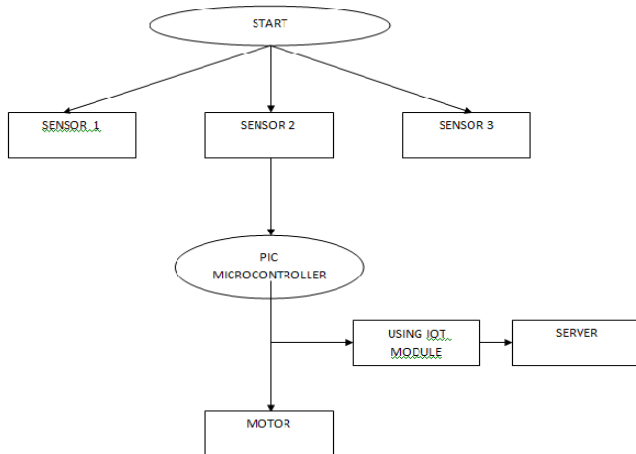

FIG 6:Flow chart of sensor node with IOT

The above flow chart gives the overview of the WSN technology for smart farming technology in an algorithm while starting the program with the coding with multiple sensors each values of the particular temperature sensor and soil moisture sensor value will be displayed in the LCD and even more the values are send to the observer if the values get exceeded motor runs as is soil moisture content is less drip ir sprinkler irrigation will be done elsewhere when the water content is more then automatically motor gets switched off. Since this technology is trustworthy helps to increase the Indian economy.

7.RESULTS

The following monitoring results are obtained using temperature, humidity and moisture sensor. These real times monitoring results are recorded on server. The graphs can be plotted. The monitoring of temperature, moisture humidity and soil moisture sensor.

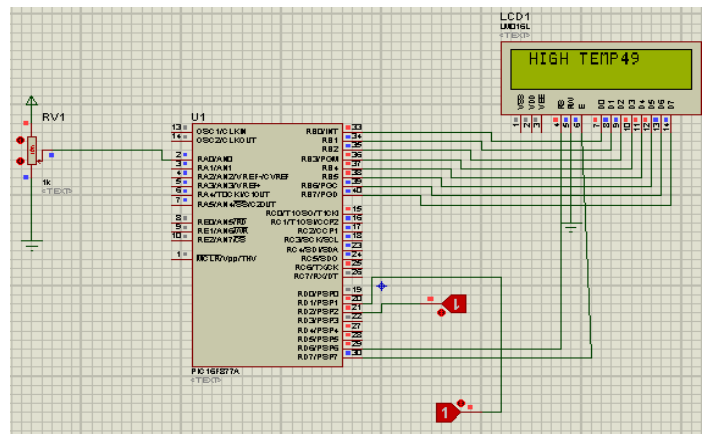

FIG 7:Temperature monitoring in Celsius

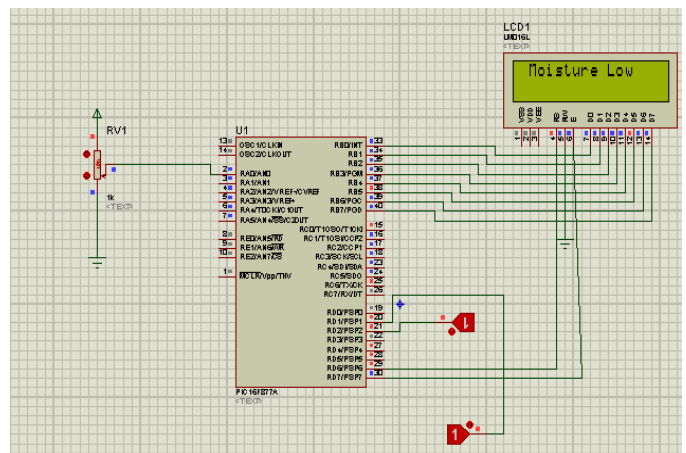

FIG 8: Soil moisture monitoring

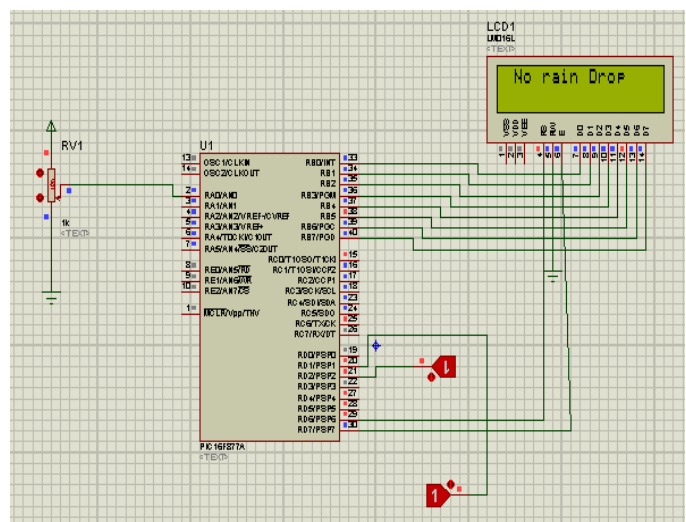

FIG 9:Rainfall sensor

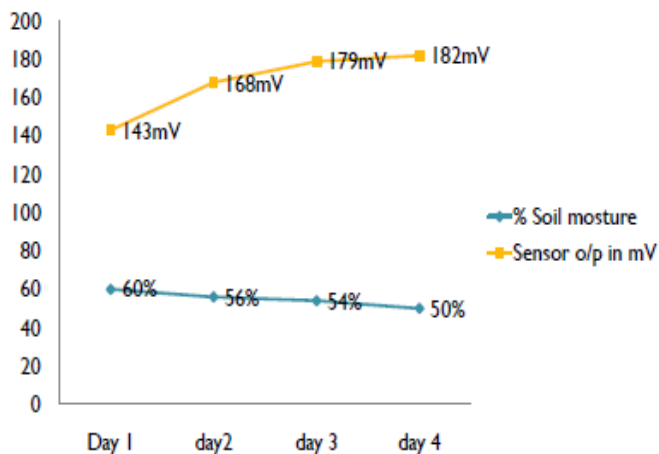

FIG 10:Soil moisture v/s sensor output

Obtained graph shows the pictorial representation of soil moisture per day.observer can easily get the information whether the soil moisture sensor is in working conditions.

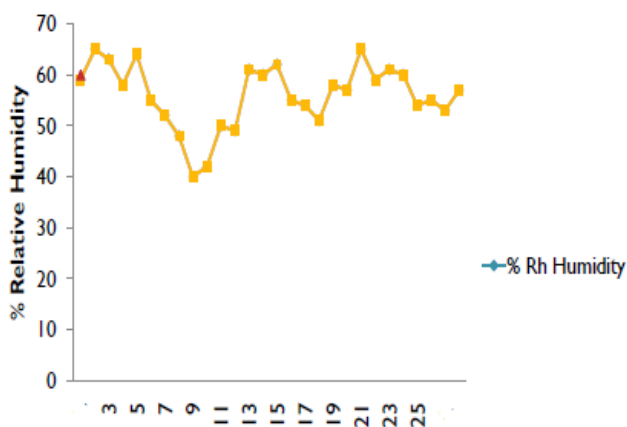

FIG 11:RH humidity sensor



FIG 12:Readings displayed in the pc using IOT

8. CONCLUSION

Wireless sensor networks use to facilitate fetching with reference to upheaval in automating agriculture. This paper would abridge plant monitoring progression and condensed human effort significantly. Client can generate bespoke environment for the plants, as a consequence providing them with most advantageous augmentation conditions. The compass for the paper can be auxiliary widened by the use of additional sensors and then storing the sensor data in the cloud enabling right to use from anywhere in the world. Also, an analog output as a replacement for of a digital one would facilitate to settle on precise sensed values.

Furthermore, interfacing the software with WSN technology would amplify its scope. The sensor values can also be rehabilitated into analog outputs. This would be of assistance receiving a comprehensible design of the environmental condition all the way through earlier period records.IOT helps to transmit the information to the observer using cloud.

9. FUTURE SCOPE

Smart unindustrialized is a perception quickly transmittable in the agricultural commerce. Offering high-precision crop control, useful data assortment and automated farming techniques This allows users organizing to documentation, carve up or restructure a unambiguous environment for growing and removes the element of pitiable weather conditions and human inaccuracy. It could also potentially allow farmers to induce drought or other abnormal conditions producing desirable persona in specific crops that wouldn't characteristically crop up in temperament.

REFERENCES

[1] Design & Implementation of Wireless Transceiver for Data Acquisition in Wireless Sensor Network Dr. R. K. Prasad , Mr. S. R. Madkar Volume 3, Issue 7, July 2013 ISSN: 2277 128X International Journal of Advanced Research in Computer Science and Software Engineering

[2] Haefke.M, Mukhopadhyay S.C and Ewald.H "A Zigbee Based Smart Sensing Platform for Monitoring Environmental Parameters "Proceedings of IEEE International Conference on Instrumentation and Measurement Technology pp1-8 May 2011.

[3] HoSeong Cho, DaeHeon Park, Chul-Young Park, Hong-Geun Kim, Chang-Sun Shin, Yong-Yun Cho, and Jang-Woo Park "A study on localization based Zigbee and Monitoring system in Greenhouse environment" Proceedings of IEEE 3rd International Conference on Data Mining and Intelligent Information Technology Applications PP190-195 oct 2011.

[4] Jeong-hwan Hwang and Hyun Yoe "Paprika Greenhouse Management System for Ubiquitous Agriculture";

Proceedings of IEEE International Conference on Information and Communication Technology Convergence pp555-556 Nov 2010.

[5] Na Pang “Zigbee Mesh Network for Greenhouse Monitoring”; Proceedings of IEEE International Conference on Mechatronic Science, Electric Engineering and Computer PP266-269 Aug 2011.

[6] A Review on data collection method with sink node in wireless sensor network. International Journal of Distributed and Parallel Systems (IJDPS) Vol.4, No.1, January 2013 DOI: 10.5121/ijdps.2013.4106 67

[7]Application based Study on Wireless Sensor Network. International Journal of Computer Applications (0975 – 8887) Volume 21– No.8, May 2011.

[8] Wireless Sensor Networks: Architecture, Protocols. International Journal of Advanced Research in 2013, IJARCSSE All Rights Reserved Page | 303 ISSN: 2277 128X. Volume 3, Issue 1, January 2013.