

# Islanding Detection and Controlled Islanding In Emerging Power Systems Key issues and challenges

Srinu Babu Matta<sup>1</sup>, Seethalekshmi K<sup>2</sup>

<sup>1</sup> Research Scholar, Electrical Engineering Department, Babu Banarasi Das University, Lucknow, Uttar Pradesh, India

<sup>2</sup> Professor, Electrical Engineering Department, Babu Banarasi Das University, Lucknow, Uttar Pradesh, India

\*\*\*

**Abstract** - Power system is continuously growing and becoming a system that is more complex day-by-day and throwing a different challenge every day. With the evolution of interconnected large and complex power grid, addition of large number of micro grids and with the ever-increasing diversity of power transmission systems due to changing power market competition, ageing infrastructure, the stability and safe operation of such power systems are stretched to their limits. This calls for an effective islanding technique of a power system to prevent the occurrence of a bulk-area blackout and/or a cascading failure. An Islanding detection of the power system, its controlled and adaptive islanding with a minimum power mismatch between separated islands are of utmost importance for reliable power system operation and its control.

This paper describes the various aspects of power system islanding, islanding detection techniques (IDT) and controlled islanding schemes (CIS). This report also describes several test methods, key issues and challenges of IDT and CIS.

**Key Words:** Controlled Islanding, Smart Grid, WAM systems, Islanding Detection, Adaptive Islanding, and Emergency Control.

## 1. INTRODUCTION

Power system, in today's scenario, includes large power plants operating in the synchronized mode and the transmission of power through long transmission and distribution network. With the evolution of interconnected large and complex power grid, addition of large number of micro grids and with the ever-increasing diversity of power transmission systems due to changing power market competition, ageing infrastructure, the stability and safe operation of such power systems are stretched to their limits and is facing major challenges. Specially, natural calamities or severe disturbances, like earthquakes, tsunamis, hurricanes, human operational errors, ransom ware, ageing infrastructure and spam ware attacks, tend to unstabilize the power system and can even trigger cascading power outages. Such cascading outages collapses the power system rapidly, resulting into a significant disruption to people, industries, institutions,

emergency services and other users at large. India witnessed two back-to-back severe blackouts on 30<sup>th</sup> and 31<sup>st</sup> July 2012, which affected the largest number of people in the history of power systems across the world. These blackouts were caused by the tripping of a certain transmission line between the northern and western power system networks of India and led to the breakdown of most of the Indian power system. [38]

The application of decentralized approach, distributed Energy Resources (DER) i.e. small or medium capacity power plants, micro grids, multiple Distributed Generators (DG) etc., in the transmission and distribution system is becoming a common practice with the increase in size of power system. The basic advantages of DER's is environmental benefits, increased efficiency, avoiding upgrading of transmission and distribution (T&D) capacity, good power quality, effective protection and control and reduced T&D line losses. However, several problems should be tackled prior to the application of DER units to the networks. These problems include frequency stabilization, voltage stabilization, intermittency of the renewable resources and micro grids and power quality issues.

A thorough review of detection of various out-of-step condition (OOS) in power transmission system is dealt with in detail in [39]. This review paper covers,

- Basic understanding of power system islanding, its associated hazards and benefits
- Islanding detection techniques. Key challenges and advantages
- Controlled Islanding schemes

The micro grid (MG), which is caused by the disconnection from the main grid without stopping the energy generation from the DG sources. This kind of disconnection from main source is called islanding, which can be either intentional or unintentional. The very need of intentional islanding is to create a "power island" in the event of a fault. To localize fault to the possible extent. However, the active part of the remaining main source would stabilize at a new operating point.

The “Unintentional islanding” is caused due to heavy power swings or unstable faults in the system. This paper highlights various techniques to identify these kind of unintentional islands and various schemes for controlled and adaptive islanding to keep the mismatch in active power between the separated islands and the main grid and the to the reasonable and optimal level. The gist of the literature survey of last two decades on the IDT and CIS are presented in this paper.

### 1.1 What is Islanding?

A fault in the power system is sensed and cleared by the protective relays and switchgear that are located nearest to the fault. In case of a fault, a DG supplies its power to the separated part of the distribution system. Mostly, DG experiences an overloaded condition, under or over voltage or frequency condition and it finally leads to stoppage, in turn, causing brown out or black out of the system. However, it is a rare case. A DG feeding this islanded system has a generating capacity that is adequate to cater to the loads connected to the islanded system. The situation in which the power to the loads is fed only from the DGs even after isolation of supply from the main power source is called an "islanded operation" or "islanding".

Controlled islanding is a process of dividing an interconnected power grid into smaller electrically independent systems having fair balance between generation and load. It is the last-resort to cope up with many technical disturbances including unstable systems, undamped oscillations, voltage collapse, cascading trips, etc. [41, 42]. The rationale behind the process of controlled islanding is that a smaller power system is easy to control and stabilize islands. Also, the islanding operation can isolate faulty part of the system from healthy part of the system.

### 1.2 Hazards of Islanding

There are potential hazards associated with Islanding in power systems.

- The voltage and frequency may not remain within a permissible range due to sudden mismatch in active power between the main power source and islanded network.
- If proper LOTO (Lock out and Tag out) system is not followed, the safety of line workers can be compromised by the availability of DG power supply after opening and tagging out of primary sources.
- The islanded system may be inadequately grounded with the new network and the associated DG interconnections.
- If Islanding is not controlled properly and instantaneous reclosing is opted out, it could result in out of phase reclosing of DG, which may cause damage to the generators due to the development of excess mechanical torques and currents.

If a condition of islanding operation is initiated because of some fault in the system then actually it is supposed to be isolated from any power supply to attend the fault. But, the fault could get continuously powered and ultimately lead to aggravating the fault, equipment failure, unsafe situation or some cascading effects because of auto islanding or MG power availability to the islanded network.

The Islanding system should be smart enough to trip further if the power quality and power condition within the islanding system is not as per acceptable limits. Early detection of islanding condition helps in deriving better control measures and, in turn, reduce and mitigate the hazards associated with islanding,

## 2. ISLANDING DETECTION METHODS

The main philosophy behind detecting an islanding condition is to determine the occurrence of an islanding situation by monitoring the DG output parameters, transmission line’s system parameters and their changes.

In the literature, various techniques been presented to detect islanding situation. All these techniques are systematically organized for better understanding in this review paper. These IDT is broadly classified into central or remote and local methods. Figure. 1 shows the classification of the IDT. The details of all techniques are explained in subsequent subsections in detail.

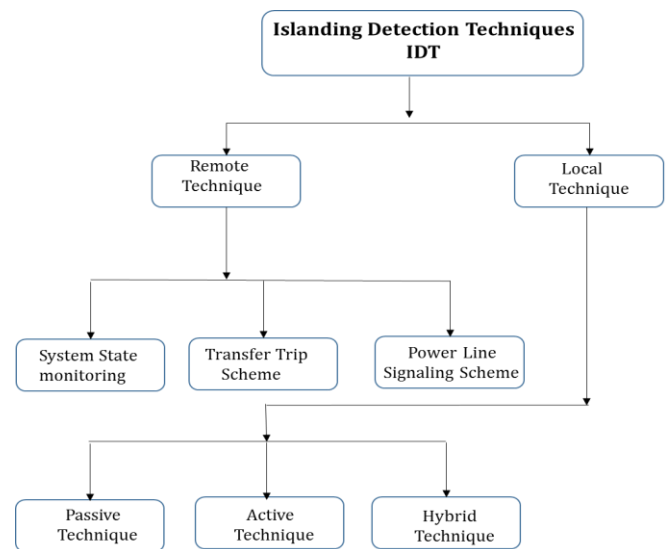

Figure. 1 : The classification of the IDT

### 2.1 Remote or Central Islanding Detection Techniques

#### 2.1.1 System State Monitoring

The method of determining system states through monitoring of the system state by modelling the power system network having lesser number of state

measurements is called System State Monitoring. Unintentional islanding can also be detected effectively through this method by devising proper instrumentation, measurement and controlling systems [1]. Once the parameters such as voltage, current and frequency are detected from the disconnected area, the islanding situation is detected. This method is derived from a complementary of the supervisory control and data acquisition (SCADA) systems, called Distribution Management System (DMS).

This technique was applied and tested in bulk power system networks, Micro grids, PV system etc. The requirement of separate instrumentation and communication equipment for each of the strategic power system equipment makes this method expensive. The problem of the high implementation cost, especially for small systems, calls for using other techniques. As the number of DGs connected the distribution network increases, the real-time monitoring of voltage of each generator becomes difficult [2]. SCADA is also used to monitor system state parameter and is used for controlling either through manual intervention or automatically.

### 2.1.2 Transfer Trip Scheme

The transfer trip scheme requires monitoring of the status of the circuit breakers and recloses that are involved in islanding a distribution system. SCADA systems can be used for such an application [3]. An effective communication system between the power system grid and DGs is required in this method. Therefore, the cost of implementing this system is, often, high. However, the method has a complexity cost because of the growth of the system complexity, where the transfer trip becomes outdated and requires relocation or updates.

### 2.1.3 Intertripping

The method comprises of transmitting of the signal of opening of a contact at the points of disconnection to the generating units supporting the respective islanded zones. Intertripping also requires communication between the measurement system and generating units. The reliability of the system is high because it provides accurate solutions but it is, as such, uneconomical [4, 5].

**Table 1 : Remote or Central Islanding Detection Techniques – Key issues and challenges**

Methods	Advantages	Disadvantages	Improvements
SCADA system (System State Monitoring)	<ul style="list-style-type: none"> <li>Communicate with all DG</li> </ul>	<ul style="list-style-type: none"> <li>Cost implementation high.</li> <li>2.Difficult to fix</li> </ul>	--
Transfer Trip Scheme	<ul style="list-style-type: none"> <li>System Concept</li> <li>Avoid NDZ</li> </ul>	<ul style="list-style-type: none"> <li>Expensive</li> <li>Complicated</li> </ul>	<ul style="list-style-type: none"> <li>Direct transfer trip can avoid islanding</li> </ul>
Wired cable or Non wired	<ul style="list-style-type: none"> <li>Easy to implement</li> </ul>	<ul style="list-style-type: none"> <li>Cost concern for DG below 2 MW (Cost impact can goes up to 50% of total connection cost.</li> </ul>	<ul style="list-style-type: none"> <li>Needs any possible media to transfer the signals</li> <li>Concerns in remote inter trip signals, where the communication media is outside the control of user.</li> </ul>

## 2.2 Local detection techniques

Local techniques use measurement of the system parameters taken from the local power system or DG site to detect islanding. The required system parameters are,

- Voltage
- Frequency
- Current
- Harmonics

Lot of research work done using local parameters is reported in the literature. An overview on local islanding

techniques is detailed in this subsection. The statistics reveals that active and passive techniques have rapidly increased their practical implementation over the years.

### 2.2.1 Passive Detection Techniques

Passive techniques involve monitoring of the system parameters such as voltage, frequency, harmonic distortion, and current on the DG end at the point of common coupling (PCC) with the main power grid or with the strategic locations of the main power grid. These parameters undergo significant change during islanding. Generally, the parameters like frequency, voltage, and its rate of change [6-12] are used to detect islanding

conditions. Various conventional and popular passive islanding detection techniques are mentioned in Figure 2.

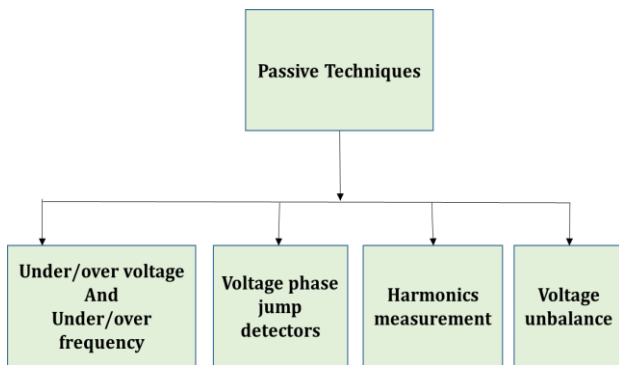

Figure 2 : Classification of Passive Techniques of IDT

### 2.2.1.1 Under/Over voltage and Under/Over Frequency:

The under/ over voltage (UVP/OVP) and under/over frequency (UFP/OF) protection relays used in this method are installed on a distribution feeder to determine the abnormalities in these parameters. These relays are used to monitor the deviation of the grid voltage/frequency beyond the permissible limits [13]. This technique is usually used at all grid connected DGs and critical nodes of power system network. These protection methods are dependent on the power flow between the main power grid and the DGs or strategic nodes of power system, which refers to active power and reactive power.

**Strengths:** The OVP/UVP and OFP/UFP relays are, in any case, required otherwise also for power system protection apart from islanding detection. This is a low-cost technique. Also, this method prevents damage to the equipment from out of operational specification conditions [39].

**Weakness:** The primary weakness of this method is its comparatively large no detection zone (NDZ), as discussed below. Also, this method has the drawback of variable or unpredictable reaction times of these protective devices.

$$\text{NDZ: If } \Delta P = \Delta Q = 0 \tag{1}$$

The change in the amplitude or frequency, in the event of disconnection of the main power grid, is not sufficient to actuate any of the standard over/under voltage or frequency relays. In such a case, the DG power generation matches the load power requirement, and the load has a unity power factor at the line frequency, P and Q being the active and reactive power of the load, respectively.

There is high probability that  $\Delta P$  and  $\Delta Q$  will fall into the NDZ of the OVP/UVP and OFP/UFP. The normal over/under voltage and frequency relays alone will be ineffective for anti-islanding protection.  $\Delta P - \Delta Q$  space can be found in the literature. As an example, this literature explains the NDZ of the over/under frequency protective devices in the RLC load space, which is shown in the figure below.  $\Delta Q$  can be calculated using the equation for reactive load and resonant frequency:

$$\Delta Q = V^2 \left\{ \frac{1}{X_C} - \frac{1}{X_L} \right\} \tag{2}$$

The fundamental frequency is given as:

$$F = \frac{1}{2\pi\sqrt{LC}} \tag{3}$$

The NDZ for changes in voltage and frequency is shown in Figure 3.

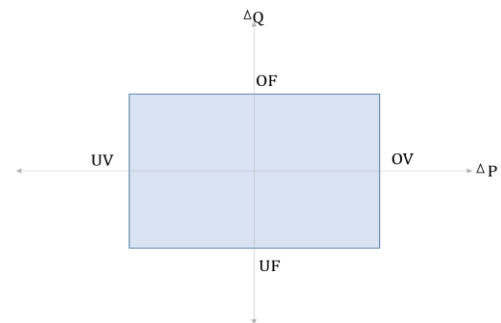

Figure 3 : NDZ for changes of voltage and frequency.

The NDZ is mapped in  $\Delta P$  versus  $\Delta Q$  Space as,

$$\Delta P = P_{load} - P_{PV} \tag{4}$$

$$\Delta Q = Q_{load} - Q_{PV} \tag{5}$$

### 2.2.1.2 Voltage Phase Jump detection

In Phase jump detection (PJD) method, the phase difference between the terminal voltage and output current of the DGs, PV systems etc. for a sudden “jump” [1] is monitored. If islanding occurs, the inverter and local load gets disconnected from the main system. The PJD technique detects islanding through a rapid change in phase angle. This method has easy implementation in case of PV, Wind turbine based DERs because only modifying the phase locked loop (PLL) used in the inverters for main power grid synchronization is needed. The capability to deactivate the inverter is only required when the phase errors exceed some threshold set value set wrt the system conditions. The power quality of the inverter remains unaffected in this method and it can be used in DER’s based on PV (Photo Voltaic), Wind turbines (WT) systems, etc. [14].



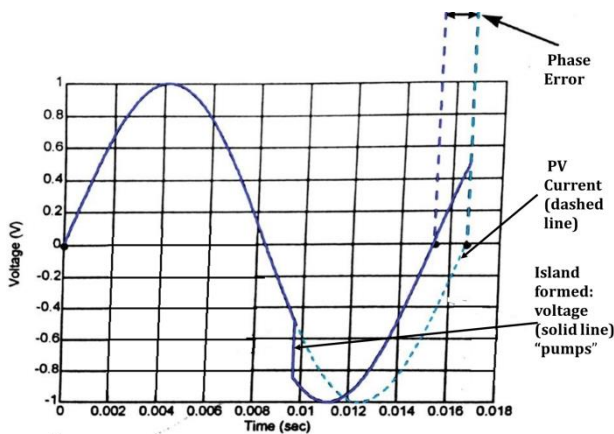

**Figure 4 : Basic operation of Phase Jump Detection**

**Strength:** A major strength of PJD is its ease of implementation. The effectiveness of PJD is effective in case of multiple inverter based DGs connected to the island.

**Weakness:** The thresholds that provide effective islanding detection are difficult to determine. The starting of certain highly inductive and dynamic loads like heavy motors, may cause significant transient phase jumps, and may lead to nuisance tripping of the PV, WT based DGs if the thresholds are set too low

**NDZ:** When the utility is disconnected, a phase error will not be generated in case of a load with a zero phase angle at the main power grid frequency. Thus, PJD has an NDZ within the passive standard of main power system over/under protection devices.

### 2.2.1.3 Harmonic Measurement

The detection of harmonics requires measurement of the harmonics (line voltages and currents) [15, 16]. The change of total harmonic distortion (THD) at the Point of coupling of the DGs and strategic points in the main power system [17] is monitored in this method. If the THD exceeds a defined threshold, the protection system will

disconnect the DGs from the main power grid. However, selecting a trip threshold, which does prevents nuisance tripping of the DGs, is easy because the distortion level rapidly changes as the nonlinear load switches on and off particularly in case of DGs based on PV, WT etc.[18].

**Strength:** Islanding can be detected effectively under a wide range of conditions [19] through this method. This method works well in case of multiple-DGs in the system.

**Weakness:** The thresholds that provide effective islanding detection are difficult to determine. It is clear that a threshold must be adaptive and selective that is

- (a) Higher than the THD, that may exist in the grid voltage.
- (b) Lower than the THD that may be developed during islanding by either of two mechanism described above.

**NDZ:** This method fails in case of loads having strong low-pass characteristics, i.e., loads with a high quality factor Q, and for loads that may occur with a service entrance disconnect that do not include a transformer inside the island.

### 2.2.1.4 Voltage Unbalance

The voltage unbalance (VU) generally varies because of the topographical changes of the networks and the load despite the small changes in the DG loading [21-23]. Therefore, effectively detecting the islanding operation is possible if the unbalance of the three-phase output voltages of the DG and strategic node of main power grid are continuously monitored. This technique is useful in the situation where disturbances occurs in the main power grid [24].

**Table 2: Islanding Detection – Passive Techniques: Key issues and challenges**

Method	Implementation Speed	Advantage	Weakness	Improvement
UFP/OFP UVP/OVP	Easy but reaction time unpredictable and variable	Used for deactivating inverter in several abnormal condition.	Large NDZ	Compared with P-V and P-Q for constant current controlled inverter
PJD	Difficult in implementation and hard to choose threshold	Does not affect output power quality of inverter and does not affect system transient response.	Failed to detect islanding when DG power generation matches the power demand of local load	Controlled by using a PLL.
THD	Easy but hard to choose threshold	Its effectiveness does not change with multiple inverter case.	Failed to detect islanded in case of low distortion of voltage and current output of inverter or high quality load.	---
Voltage unbalance	----	Effectively detecting the islanding operation is possible.	Not applicable to signal phase system.	Combine two or more methods

### 2.2.2 Active Detection Techniques

These techniques are mostly preferred these days because of their real time based approach. Various active islanding detection techniques with non-artificial intelligent techniques exist, some of the popular techniques are discussed in this subsection. [21, 22, 25].

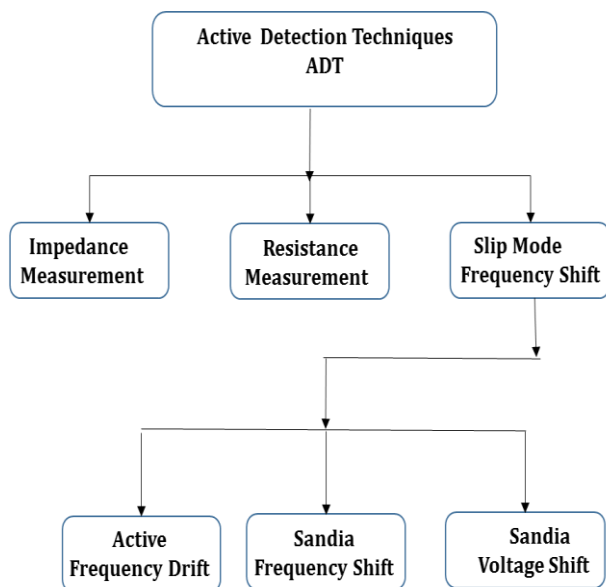

**Figure 5: Classification of Active Techniques of IDT**

#### 2.2.2.1 Impedance Measurement

In the impedance measurement based technique, it measures the system impedance changes caused by islanding. An active direct method, however, involves connecting a shunt inductor across the supply voltage, intermittently, and the power system source impedance, detailed in [21, 22] is calculated from the short circuit current and supply voltage reduction. A large number of impedance detection methods been proposed because of the belief that this method has no NDZ in the single PV or WT based DG case.

$$\Delta V = \frac{\Delta P}{2} \sqrt{\frac{R}{P}} \tag{6}$$

Given the parallel RLC load, however, the major trouble for impedance detection is caused by high-Q loads. Rate of change of Impedance and difference in rate of change of impedance at sending end and receiving end of the transmission line is used as a basis for deciding upon the islanding situation. [40].

#### 2.2.2.2 Resistance Measurement

In this technique, swing detection algorithm is used to detect the islanding situation [40]. The Figure 6 depicts the working flow chart of the Resistance measurement based technique.

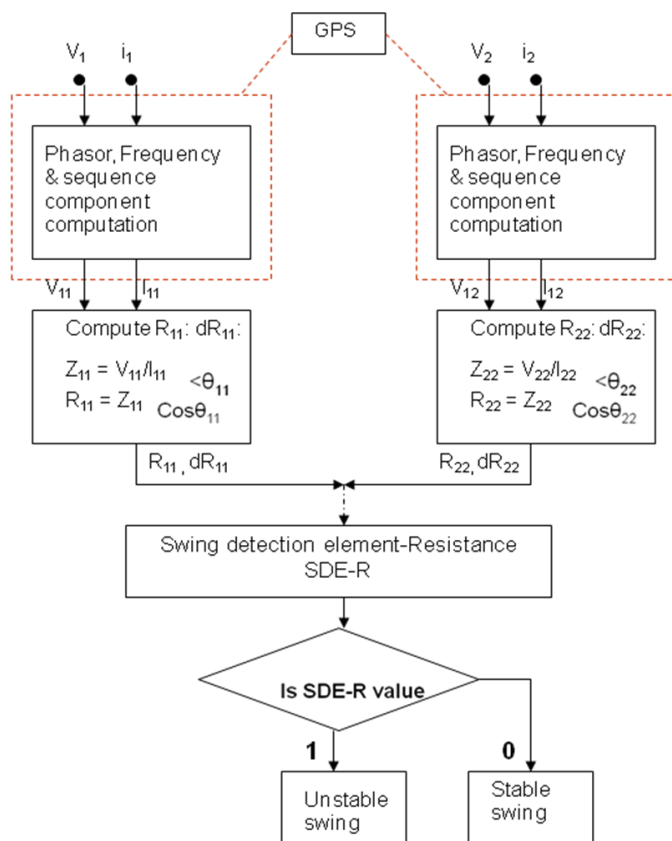

**Figure 6. Flowchart for the resistance measurement based IDT**

This Swing detection element, checking criteria to ascertain the out of step condition during stable or unstable power swings. The algorithm comprises of four types of sub-elements as shown here, namely “Magnitude of change detection element”, “Rate of change detection element”, “differential magnitude of change detection element” and “Differential rate of change detection element”.

All the parameters like T1 to T4, K1 to K4, R1set, R2set, ΔTmax and ΔT are precisely set after conducting thorough study of the system configuration & its transient analysis. If either of the “Magnitude of change detection element” and “Rate of change detection element” sets along with either of the “differential magnitude of change detection element” and “Differential rate of change detection element”, then only the Swing Detection Element gives a positive output, this signal can be used for controlled tripping or for any power shedding application etc.

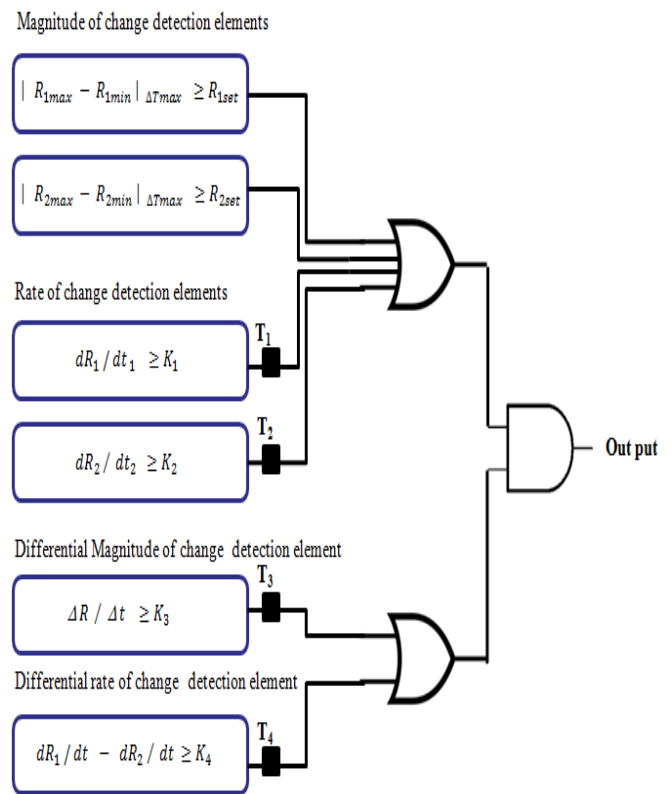

**Figure 7. Algorithm of Swing Detection Element**

The response of this technique is very fast and reliable. However, the arriving on a certain threshold values and timer setting is challenging with the changing power system conditions.

### 2.2.2.3 Slip Mode Frequency shift (SMS)

SMS uses positive feedback for islanding detection, namely, amplitude, frequency and phase. The method comprises of shifting the phase and the short-term frequency by applying a positive feedback to the phase of the voltage. The SMS is used to detect the islanding condition because of the easy implementation of the method caused by the involvement of only a slight modification of a required component. SMS also prevents islanding effectively and it is having small NDZ compared with other active techniques [26].

#### 2.2.2.3.1 Active Frequency Drift (AFD):

The principle of the active frequency drift (AFD) or frequency bias method is used in PV, WT based DG system. In this method, the frequency of the inverter current is accelerated [2, 27] by forcing variations in the inverter output using positive feedback. The AFD uses the waveform of the inverter current, which is injected into the PCC with the main power grid. The waveform drifts of the grid is not present as a stabilizing influence. The advantage of AFD is the ease of implementation in PV or

WT based DGs. However, all inverters of the PV based micro grid should possess identical AFD, otherwise, it would fail to detect islanding conditions in the multiple inverter case [6].

### 2.2.2.3.2 Sandia Frequency Shift (SFS)

The SFS method, normally termed as AFDPF, is derived from the AFD and it uses positive feedback for islanding detection [17]. SFS is also used to detect the deterioration of the islanding condition. This method’s performance of the SFS method is notably dependent on the optimal design of its parameter. The optimal setting of the SFS islanding detection parameters with a multi DG system is vital to eliminate the NDZ condition.

### 2.2.2.3.3 Sandia Voltage Shift (SVS):

The SVS, based on positive feedback, is a method of islanding detection, which applies positive feedback to the amplitude of the voltage. SVS is most effective in islanding prevention among AFD and SFS methods. However, SVS may produce minimal effects on the main power grid system’s transient response and power quality. An active technique was used by adding the disturbance current through the voltage-source control (VSC) to detect the islanding condition effectively. The variation of the time-varying amplitude of the PCC voltage is also determined when the disturbance remains constantly unchanged [10]. This method is faster in detecting islanding and has a smaller NDZ than the normal technique if the suitable accelerating factor is selected, the only gap with this technique is selection of rightful accelerating factor under dynamic power system conditions.

**Table 3: Islanding Detection – Active Techniques: Key issues and challenges**

Method	Implementation and Speed	Advantage	Weakness	NDZ
<b>Impedance Measurement</b>	Easy and fast	Extremely small NDZ for a DG of PV or WT based system	--	Large for high Q load
<b>Resistance Measurement</b>	Easy and fast	Extremely small NDZ	--	Large for high Q load
<b>SMS</b>	Medium and slow	SMS is also highly effective in islanding prevention (small NDZ)	Ineffective under certain load e.g. RLC resonant load	Large for high Q load
<b>AFD</b>	Easy and medium	Ease of implementation in microcontroller-based inverters	--	Large for high Q load
<b>SFS</b>	Difficult and relatively fast	Extremely effective in combination with SVS.	Problem in power quality, system stability	Exist for high Q load but less compared to others
<b>SVS</b>	Medium and fast	Applies positive feedback to the amplitude of the voltage. So highly affective.	Increased harmonic distortions	Very less

### 2.2.3 Hybrid Techniques

The hybrid technique is a combination of the active and passive IDT’s. Various Hybrid techniques are discussed in this subsection.

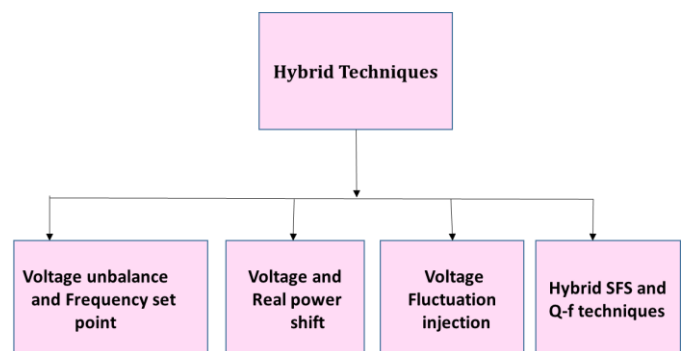

**Figure 8. Classification of Hybrid Techniques**



### 2.2.3.1 Voltage unbalance and frequency set point

Hybrid method is based on the positive feedback (PF) and the voltage unbalance and total harmonic distortion (VU/THD) techniques, wherein, the drawback of both techniques are cancelling each other when simultaneously applied [28]. The calculation of the VU for each of the DG is used instead of the THD, because the VU is more sensitive to disturbance than THD. Therefore, any disturbance applied to DGs could produce a spike in the VU. This technique also efficiently discriminates between the islanding condition and the event of switching of load.

### 2.2.3.2 Technique based on voltage and real power shift

This technique uses an average rate of the voltage change ROCOV (passive technique) and a real power shift (active technique) to overcome the limitations of the active and passive techniques in islanding detection [29]. The technique can detect the islanding condition with multiple DG units operating at unity power factor.

However, the real power shift (RPS) is applied to the system if islanding condition is not detected by the passive technique. RPS can eliminate the injecting disturbance from time to time to detect islanding similar to other active techniques. However, RPS only can change the real power of the DG at the unity power factor. In the proposed method, only one DG changes the real power compared with the positive feedback technique, where all the DGs work together to inject perturbation in the system [29].

### 2.2.3.3 Voltage Fluctuation Injection

As the name of this technique goes, it is based on the voltage fluctuation injection, using a high impedance load. The islanding detection correlation factor (CF) is proposed for small-scale DGs. The two-stage method, which is the passive technique (rate of change of frequency (ROCOF)/rate of change of voltage (ROCOV)) for the protection scheme, and the active technique (CF) as a backup is applied to attain higher effectiveness of the CF of the distribution synchronous generator and to accurately decide between islanding and non-island disturbances [30].

### 2.2.3.4. Hybrid SFS and Q-f islanding technique:

The SFS and Q-f curves are proposed based on islanding detection to improve the SFS and reduce the NDZ [31].

The optimum SFS is calculated using the analytic formula, where the bacterial foraging algorithm is being used to search the optimal gain of the SFS to eliminate NDZ. The Q-f droop curve technique is then added to increase the effectiveness and the responsiveness of the SFS- based islanding detection.

Key issues and advantages with various Islanding detection techniques tabulated in Table 4.

## 2.3 SIGNAL PROCESSING METHODS

It is used for identification of islanding situation. Quick and accurate detection of the islanding condition is of utmost importance. The implementation of the signal processing technique assists in detecting the islanding condition. The hidden features extracted through signal processing can then serve as inputs to the artificial intelligent (AI) classifier, which helps in detecting the islanding and non-islanding conditions.

Common AI classifiers or machine learning based classifiers used in islanding detection include the decision tree (DT), rule based techniques, artificial neural network (ANN), probabilistic neural network (PNN), fuzzy logic (FL), and support vector machines (SVM). The signal processing methods present various features, such as time-frequency distribution (TFD) of a time series, which eases the analysis and quantification of the signals regardless of the succeeding classification technique. The linear TFD techniques are popularly implemented in determining the islanding condition because such implementation is faster than those of non-linear methods. Some of the SP tools used in islanding detection are described in the following sections. The islanding detection techniques that use signal processing and the succeeding AI classifiers or machine learning classifiers are discussed further in the following subsections.

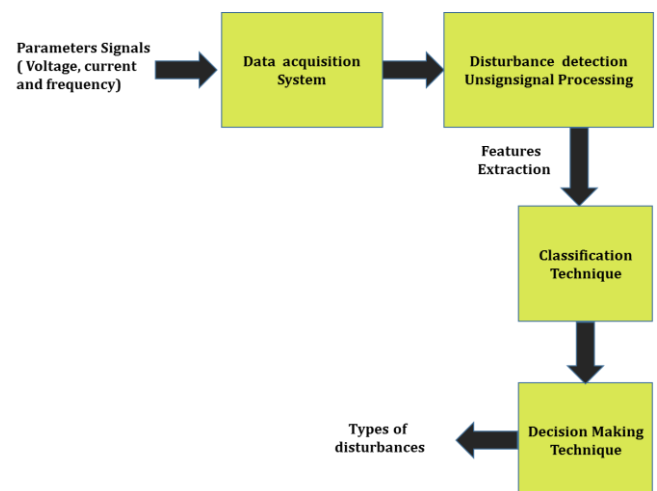

Figure 9. Classification of Signal Processing Methods

**Table 4: Islanding Detection techniques: Key issues and challenges**

Islanding Detection Techniques	Advantages	Disadvantages	Examples
Remote Techniques	Highly reliable	Expensive to implement especially for small systems.	Transfer trip scheme Power line signaling scheme
Local Techniques			
Passive technique	<ul style="list-style-type: none"> <li>- Short detection time</li> <li>- Do not perturb the system</li> <li>- Accurate when there is a large mismatch in generation and demand in the islanded system</li> </ul>	<ul style="list-style-type: none"> <li>- Difficult to detect islanding when the load and generation in the islanded system closely match</li> <li>- Special care has to be taken while setting the thresholds</li> <li>- If the setting is too aggressive then it could result in nuisance tripping</li> </ul>	<ul style="list-style-type: none"> <li>- Rate of change of output power scheme</li> <li>- Rate of change of frequency scheme</li> <li>- Rate of change of frequency over power scheme</li> <li>- Change of impedance scheme</li> <li>- Voltage unbalance scheme</li> <li>- Harmonic distortion scheme</li> </ul>
Active Techniques	<ul style="list-style-type: none"> <li>- Can detect islanding even in a perfect match between generation and demand in the islanded system (Small NDZ)</li> </ul>	<ul style="list-style-type: none"> <li>- Introduce perturbation in the system</li> <li>- Detection time is slow as a result of extra time needed to see the system response for perturbation</li> <li>- Perturbation often degrades the power quantity and if significant enough, it may degrade the system stability even when connected to the grid.</li> </ul>	<ul style="list-style-type: none"> <li>- Reactive power export error detection</li> <li>- Impedance measurement scheme</li> <li>- Phase (or frequency) shift schemes (like SMS, AFD, AFDPF and ALPS)</li> </ul>
Hybrid Techniques	<ul style="list-style-type: none"> <li>- Have small NDZ.</li> <li>- Perturbation is introduced only when islanding is suspected</li> </ul>	<ul style="list-style-type: none"> <li>- Islanding detection time is prolonged as both passive and active technique is implemented</li> </ul>	<ul style="list-style-type: none"> <li>- Technique based on positive feedback and voltage imbalance</li> <li>-</li> </ul>

### 2.3.1. Wavelet-transform (WT)

The wavelet theory is the mathematical model for non-stationary signals with a set of components in the form of small waves called wavelets or Burst mode transform [32]. The wavelets are generated from one original wavelet called the mother wavelet, which is then further extended to allow the wavelet to analyze the non-stationary signals in the frequency band. WT can be either continuous (CWT) or discrete (DWT). Using a wavelet is advantageous because the wavelet does not need to assume the stationary or periodicity of signal. The WT carries information about time and frequency simultaneously is

capable of simultaneously comprehending time and frequency information because wavelet has long windows at low frequencies and short windows in high frequencies. Therefore, WT can be used for islanding detection by analyzing the discontinuities and transients in time-varying signals. CWT is applied using an online measuring technique for the voltage in DG units and strategic nodes of the main power grid [33].

### 2.3.2. S-transform (ST)

WT suffers from the problem that it is unable to detect islanding conditions under a noisy condition. [34-36]. In S-transform, which is a modified form of WT, the real and imaginary spectra of a frequency-dependent resolution are localized by producing a time-frequency representation of a time series. S-transform eliminates the presence of noise by providing multi-resolution but the absolute phase of each frequency component is retained.

The S-transform was used to extract the negative sequence voltage during an islanding event. The energy content and standard deviation of the S-transform contour was clearly shown in detecting islanding events and disturbance because of load rejection in [37]. Calculation of the negative sequence voltage and current through the S-transform and spectral energy content was done. S-transform requires more computation time and memory for signal processing, which is a drawback [35-36]

## 3. CONTROLLED ISLANDING

Controlled islanding of power system prevents wide-area blackouts and/or cascading failures, this helps in maintaining the stability of power systems under contingencies. Its main purpose is to localise the faulty zones, avoid cascading failures and reduce the impact of disturbances by limiting out-of-step conditions. WAMS in power networks provide time stamped measurements and which can be used for faster and reliable controlled islanding.

Several approaches proposed for controlled islanding in the literature.

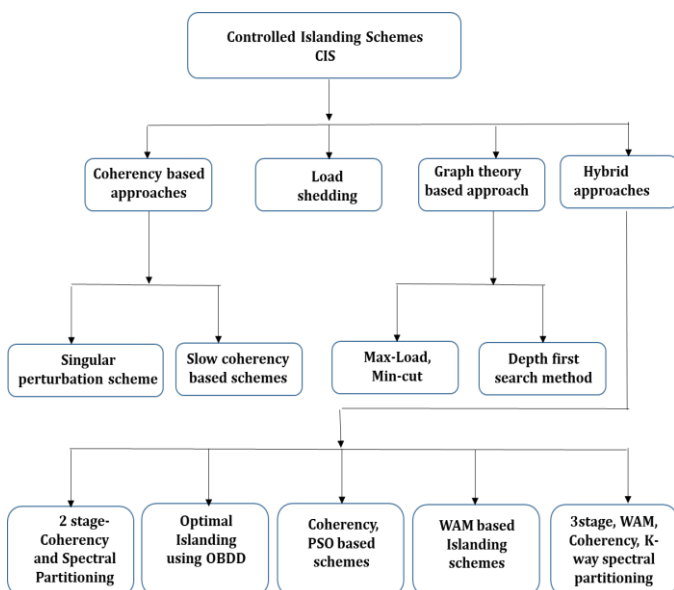

Figure 10. Classification of Controlled Islanding schemes (CIS)

The system is split into self-sufficient islands through a slow coherency approach [43-45]. The rate of change of frequency (ROCOF) is monitored to arrive upon a load-shedding scheme, thus preventing frequency fluctuation in heavily loaded islands..

Peponides et al. [46] proposed to identify slow coherence in the power system through the singular perturbation technique. The system's working mode can be classified broadly into slow mode and fast mode. When a disturbance occurs, the dynamic system is in the fast mode, which gradually gives way to the slow mode.

Incorporating external constraints like limited island zone or constructing some simpler criteria like degree of generators' coherency or dynamic coupling in the pre-islanding system state are detailed in [47-49]. In [50-51] papers, stability constraints and other key parameters were not considered and mostly focused on minimization of side effects of the islanding process and only a single aspect like load shedding or combination of other system aspects.

In [52], an improved slow coherence method was described and used to obtain an islanding strategy and in [53-54], the problem of controlled islanding was resolved through the graph-theoretic method. This type of method involves identification of the minimal cut-set and the weak link with graph simplification approaches [55-56] and depth-first searching methods.

a two-step controlled islanding algorithm was proposed in [47], where spectral clustering was used to find a favourable islanding solution, but the generator coherency after disturbances is not considered, as the coherency changes before and after a major disturbance. Here, the drawback is that, it only considers the absolute value of active power, ignoring the direction of power flows and the influence of electrical distances between generators, whereas these are important parameters for optimal controlled islanding.

There are several research papers on different methods for determination of the optimal islanding boundaries on real-time basis apart from the slow coherency-based islanding strategy. Sun et al. [43, 57] introduced and extended the ordered binary decision diagram (OBDD) method using power system transient simulation to split the power system into stable islands to identify the islanding cut-set and analyse the minimum power mismatch. In [58-60], researchers used intelligent optimization algorithms, such as the ant searching mechanism and particle swarm optimization to search for proper islanding solutions with a minimum mismatch of power flow. In [62], Trajectory similarity based coherency approach is dealt with along with entropy weight and used in controlled islanding. In [61], WAM based controlled islanding has been proposed, which has Variable Neighbourhood. Heuristic approaches are used additionally for optimised power mismatch. Proposed

approach has been compared with this approach and it was found that the power mismatch in the proposed approach is lower and faster in response time.

The advent of Phasor Measurement Unit (PMU) with time stamped Global Positioning System (GPS) enabled Wide Area Measurement System (WAM) eliminated challenges from the geographic spread, separation of power systems and also measurements are able to give real time power system phasors at a rate of 20-60 phasors / second [63-64]. WAM has been broadly deployed in power systems worldwide these days. WAM enables the dynamic measurements of current's, voltages, parameters of generators etc. and helps developing faster and reliable solution for controlled islanding problem.

A new Adaptive and WAMS-based three stage controlled islanding strategy for large interconnected power systems is proposed in [65]. In the First stage, signal-characteristic-analysis is undertaken to discriminate a power fault condition from other power quality issues. Four similarity indexes associated with the generators' trajectories were used to find out coherent Generators. In the second stage, an improved-Laplacian-Eigen-map algorithm (ILEA) to identify the distance measured in kernel space between generators has been used. Hierarchical clustering used for easy representation of Generators coherency. In the third stage, utilized k-way-partitioning (KWP) and Graphical-Spectral-Partitioning algorithms to obtain separation surfaces and least power-mismatching islanding lines. This scheme was tested on IEEE 39-bus system, its results are better than OBDD and WAM based coherency-based scheme and it is automatically adapting to different fault modes and giving optimum islanding.

#### 4. CONCLUSIONS

In this paper, an extensive analysis and review of literature (more than 110 papers) of last two decades on the Power system islanding, Islanding detection and controlled islanding are presented in a comprehensive and easily understandable manner. The various systems of islanding detection techniques including centralised or remote and local, conventional and modern techniques in a power system transmission and distribution system are presented in detail. Various intelligent system applications in islanding detection have also been discussed along with their key challenges and advantages. An overview of controlled islanding schemes (CIS) is also presented.

This paper provides an unbiased description of each of the islanding detection techniques (IDT) and controlled islanding schemes (CIS) along with discussions of the strengths, weaknesses and non-detection zone characteristics for the convenience of readers and also to create a broader spectrum of understanding.

#### REFERENCES

- [1] Balaguer-álvarez I and Ortiz-rivera E., "Survey of distributed generation islanding detection methods", IEEE Latin America Transactions 2010, vol. 8, pp.565-570.
- [2] Yin, J, Chang, L and Diduch, C., "Recent developments in islanding detection for distributed power generation", Power engineering, 2004, pp. 124-128.
- [3] M. A. Refern, O. Usta, and G. Fielding, "Protection against loss of utility grid supply for a dispersed storage and generation unit," IEEE Transaction on Power Delivery, vol. 8, no. 3, pp. 948-954, July 1993.
- [4] Chowdhury S, Chowdhury S and Crossley P., "Islanding protection of active distribution networks with renewable distributed generators: a comprehensive survey", Electric Power Systems Research, 2009, pp. 984-92.
- [5] Ecconnect, "Assessment of islanded operation of distribution networks and measures for protection", Polymercontents, vol.18, 2001, pp.830-877.
- [6] Kunte, R, and Gao, W, "Comparison and review of islanding detection techniques for distributed energy resources", 40<sup>th</sup> North American power symposium, 2008, pp.1-8.
- [7] Moradzadeh, M, Rajabzadeh, and M, Bathaee, M, "A novel Hybrid islanding detection method for distributed generations", Third international conference on electric utility deregulation and restructuring and power technologies, 2008, pp.2290-2295.
- [8] Zeineldin H., and Salma M., "Impact of load frequency dependence on the NDZ and performance of the SFS islanding detection method", IEEE Transaction on Industrial Electronics 2011, pp.139-46.
- [9] Yoo, C, Jang, D, Han, S, Oh, D and Hong, S., "A new phase drift anti-islanding method for grid-connected inverter system", Eighth international conference on power electronics—ECCE Asia, 2011, pp.902-906.
- [10] Li P, Sheng Y, Zhang L, Yang X and Zhao Y., "A novel active islanding detection method based on current disturbing", Electrical Machines and Systems 2009, vol.1, pp.1-5.
- [11] Lee S., and Park J., "New islanding detection method for inverter-based distributed generation considering its switching frequency", IEEE Transaction on Industry Applications 2010, 46, pp.2089-2098.
- [12] Yu B, Matsui M, and Yu G., " A correlation based islanding detection method using current magnitude disturbance for PV system", IEEE Transaction on Industrial Electronics 2010,58, pp.2935-43.
- [13] Timbus, A, Oudalov, A, and Ho, C., "Islanding detection in smart grids", Energy conversion congress and exposition (ECCE), 2010, pp.3631-3637.
- [14] Hu W, and Sun Y., "A compound scheme of islanding detection according to inverter", Asia-Pacific



- power and energy engineering conference, 2009, pp.1-4.
- [15] Khamis A, Armstrong M, Sulaiman M, and Rahman A., "Location of embedded generation installation at long distribution line feeder due to harmonic performances", IJSSST, 2009, Vol. 10.,pp.26-33.
- [16] Khamis, A, Armstrong, M., and Sulaiman, M., "The impact of embedded generation due to harmonic performance", Third Asia international conference on modelling and simulation, 2009, pp.514-519.
- [17] Teoh W., and Tan C., "An overview of islanding detection methods In photovoltaic systems", World Academy of Science Engineering and Technology, 2011, pp.674-82
- [18] Yin, GA, "Distributed generation islanding detection method based on artificial immune system", IEEE/PES transmission & distribution conference & exposition -Asia and Pacific, 2005, pp.1-4.
- [19] Kobayashi, H., Takigawa, K., and Hashimoto, E., "Method for Preventing Islanding Phenomenon on Utility Grid with a Number of Small Scale PV Systems", Proceedings of the 21st IEEE Photovoltaic Specialists Conference, 1991, pp.695-700.
- [20] Ropp, M., "Design Issues for Grid-Connected Photovoltaic Systems", Ph.D. dissertation, Georgia Institute of Technology, Atlanta, GA, 1998.
- [21] Mahat P., and Bak-Jensen B., "Review of islanding detection methods for distributed generation", Third international conference on electric utility deregulation and restructuring and power technologies, 2008, pp.2743-2748.
- [22] Mahat P, Chen Z., and Bak-jensen B., "Review on islanding operation of distribution system with distributed generation", Power and energy society general meeting, 2011, pp.1-8.
- [23] Jang S, and Kim K., "An islanding detection method for distributed generations using voltage unbalance and total harmonic distortion of current", IEEE Transaction on Power Delivery, 2004, 19, pp.745-752.
- [24] Thomas M, and Terang P., "Islanding detection using decision tree approach", Power Electronics, Drives and Energy Systems (PEDES), 2010, pp.1-6.
- [25] Bae B, Jeong J, Lee J, and Han B., "Islanding detection method for inverter-based distributed generation systems using a signal cross-correlation scheme", Journal of Power Electronics 2010, 10, pp.762-768.
- [26] Zeineldin H, El-Saadany E, and Salama M., "Impact of DG interface control on islanding detection and non detection zones", IEEE Transactions on Power Delivery, 2006, 21, pp.1515-1523.
- [27] Hanif M, Street K, and Gaughan K., " A discussion of anti-islanding protection schemes in corporate in a inverter based DG", Environment and Electrical Engineering (EEEIC), 2011, pp.1-5.
- [28] Menon V, and Nehrir M., "A hybrid islanding detection technique using voltage unbalance and frequency set point", IEEE Transactions on Power Systems, 2007, 22, pp.442-448.
- [29] Mahat P, Chen Z, and Bak-jensen B., "A hybrid islanding detection technique using average rate of voltage change and real power shift", IEEE Transactions on Power Delivery, 2009, 24, pp.764-771.
- [30] Chang WA., "Hybrid islanding detection method for distributed synchronous generators", The International power electronics conference, 2010, pp.1326-1330.
- [31] Vahedi H, Noroozian R, Jalilvand A, and Gharehpetian G., "Hybrid SFS and Q-f islanding detection method for inverter-based DG", IEEE international conference on power and energy (PECon2010), 2010, pp.672-676.
- [32] Polikar R., "The story of wavelets", IMACS/IEEE CSCC'99 Proceedings, 1999, pp.5481-5486
- [33] Zhu Y, Yang Q, Wu J, Zheng D, and Tian Y., "A novel islanding detection method of distributed generator based on wavelet transform", Electrical Machines and Systems-ICEMS2008, 2008, pp.2686-2688.
- [34] Ray P, Mohanty S, Kishor S, and Dubey H., "Coherency determination in grid-connected distributed generation based hybrid system under islanding scenarios", IEEE international conference on power and energy- PECon2010, 2010, pp.85-88.
- [35] Ray P, Kishor N, and Mohanty S., "S-Transform based islanding detection in grid-connected distributed generation based power system", IEEE international energy conference, 2010, pp.612-617.
- [36] Ray P, Mohanty S, and Kishor N., " Disturbance detection in grid-connected distributed generation system using wavelet and S-Transform", Electric Power Systems Research, 2011, pp.800-805
- [37] Samantaray S, Samui A, and Babu B., "S-Transform based cumulative sum detector (CUSUM) for islanding detection in distributed generations", Power Electronics, Drives and Energy Systems-PEDES, 2010, pp.1-6.
- [38] Report on the Grid Disturbances on 30th July and 31st July 2012, Ministry of Power, Government of India
- [39] Srinu Babu Matta and Seethalekshmi K, "Out-of-step detection in emerging power systems - key issues and challenges", The Journal of CPRI (Central Power Research Institute ), India, Vol. 10, No. 3, September 2014, pp. 427-440.
- [40] Srinu Babu Matta and K. Seethalekshmi, "Out-of-step detection using Wide Area Measurements", CIGRE International conference, Global Learning Centre-Infosys, Mysore, India, 13<sup>th</sup>-15<sup>th</sup> November 2013.
- [41] Ahmed, S.S., Sarker, N.C., Khairuddin, A.B et al., (2003), A scheme for controlled islanding to prevent subsequent blackout. Power Systems, IEEE Transactions on 18(1), 136-143.



- [42] Sun, K., Zheng, D.Z. and Lu, Q. (2003), Splitting strategies for islanding operation of large-scale power systems using OBDD-based methods. *Power Systems, IEEE Transactions on* 18(2), 912-923.
- [43] X. Wang and V. Vittal, (2004), System Islanding Using Minimal Cut sets with Minimum Net Flow, *Proceedings of the 2004 IEEE PES Power System Conference and Exposition, New York.*
- [44] You, H., V. Vittal, and Z. Yang, (2003), Self-Healing in Power Systems, An Approach using Islanding and Rate of Frequency Decline-Based Load Shedding, *IEEE Trans. on Power Systems*, vol.18, No.1, pp 174-181.
- [45] You, H., V. Vittal, and X. Wang, (2004), Slow Coherency-Based Islanding, *IEEE Trans. on Power Systems*, vol. 19, No. 1, pp 483-491.
- [46] Peponides, G., Kokotovic, P.V and Chow, J.H. (1982), Singular perturbations and time scales in nonlinear models of power systems. *IEEE Trans. Circuits Systems*, 29, 758-767.
- [47] Ding, L., Gonzalez-Longatt and F.M., Wall et al., (2013). Two-step spectral clustering controlled islanding algorithm. *Power Systems, IEEE Transactions on* 28(1), 75-84.
- [48] Quirós-Tortós, J., Wall, P. and Ding, L. et al., (2014), Determination of sectionalising strategies for parallel power system restoration: A spectral clustering-based methodology. *Electric Power Systems Research* 116, 381-390
- [49] Trodden, P.A., Bukhsh, W.A. and Grothey, A. et al. (2014), Optimization-based islanding of power networks using piecewise linear ac power ow. *Power Systems, IEEE Transactions on* 29(3), 1212-1220.
- [50] Pahwa, S., Youssef, M. and Schumm, P., (2013), Optimal intentional islanding to enhance the robustness of power grid networks. *Physica A: Statistical Mechanics and its Applications* 392(17), 3741-3754
- [51] You, H., V. Vittal, and Z. Yang, (2003), Self-Healing in Power Systems, An Approach using Islanding and Rate of Frequency Decline-Based Load Shedding, *IEEE Trans. on Power Systems*, vol.18, No.1, pp 174-181.
- [52] Wang, X. (2005), Slow Coherency Grouping Based Islanding Using Minimal Cut-Sets and Generator Coherency Index Tracing Using the Continuation Method. Ph.D. Thesis, Iowa State University, Ames, IA, USA
- [53] Kumar, M.M. and Swarup, K.S., (2010), Graph theoretic approach for preventive control of power system. *International Journal of Electrical Power Energy Systems*, 32, 254-261.
- [54] Sen, A., Ghosh, P. and Vittal, V., (2009), A new min-cut problem with application to electric power network partitioning. *European Transmission Electrical Power*, 19, 778-797.
- [55] Quirós-Tortós, J., Wall, P. and Ding, L. et al., (2014), Determination of sectionalising strategies for parallel power system restoration: A spectral clustering-based methodology. *Electric Power Systems Research* 116, 381-390
- [56] Report on the Grid Disturbances on 30th July and 31st July 2012,(2012), Ministry of Power, Government of India
- [57] Sun, K., Zheng, D.Z. and Lu, Q., (2005), A simulation study of OBDD-based proper splitting strategies for power systems under consideration of transient stability. *IEEE Trans. Power Syst.*, 20, 389-399.
- [58] El-Zonkolym, A., Saad, M. and Khalil, R., (2013), New algorithm based on clpso for controlled islanding of distribution systems. *Int. J. Electrical Power Energy Systems*, 45, 391-403.
- [59] Aghamohammadi, M.R. and Shahmohammadi, (2012), A. Intentional islanding using a new algorithm based on ant search mechanism. *International Journal of Electrical Power Energy Systems*, 35, 138-147.
- [60] Li Liu a, Wenxin Liu and David A. Cartes., (2009), Slow coherency and Angle Modulated Particle Swarm Optimization based islanding of large-scale power systems, *Advanced Engineering Informatics* 23 45-56
- [61] Honglei, S., Junyong, W. and Kui, W. (2014), A Wide-Area Measurement Systems-Based Adaptive Strategy for Controlled Islanding in Bulk Power Systems, *Energies* 2014, 7, 2631-2657.
- [62] Zhenzhi, L., Fushuan, W. and Junhua, Z., et al. (2016), Controlled islanding schemes for interconnected power systems based on coherent generator group identification and wide-area measurements, *Journal of Modern Power Systems and Clean Energy* 4(3), 440-453
- [63] Nourizadeh, S., Sarmadi, S.A. and Karimi, M.J. (2012), Power system restoration planning based on wide area measurement system. *International Journal of Electrical Power Energy Systems*, 43, 526-530.
- [64] Sun, K, Hur, K. and Zhang, P., (2011), A new unified scheme for controlled power system separation using synchronized phasor measurements. *IEEE Trans. Power Syst.*, 26, 1544-1554.
- [65] Srinu Babu Matta and Seethalekshmi K, "An Adaptive Islanding - Three Step Controlled Islanding Strategy", *International Journal of Engineering Science and Technology (IJEST)*, Vol. 9, Issue 05, May 2017, pp. 516-527.

**BIOGRAPHIES**

Srinu Babu Matta, Research Scholar in Electrical Engineering Department, BBD University, Lucknow, India. Smart Grid, Adaptive Islanding, Optimal Controlled Islanding, and WAM systems are areas of research interest.



Dr. Seethalekshmi K., Professor in Electrical Engineering Department of BBD University, Lucknow, India. Smart Grid, Adaptive Distance Protection, WAM systems, and Adaptive islanding are areas of research interest.