

# DESIGN, ANALYSIS AND OPTIMIZATION OF CURVE ATTACHMENT ON COMPOSITE HYBRID LAP JOINT

S. Sridhar<sup>1</sup>, S. Lakshmi Narayanan<sup>2</sup>

<sup>1</sup>Master's in CAD/CAM Engineering, CIPET- Chennai, Govt. of India.

<sup>2</sup>Assistant Professor, Department of Manufacturing Engineering, CIPET- Chennai, Govt. of India.

\*\*\*

**Abstract** - The objective of this study is to find a better joint configuration which has more strength with minimum added weight. Hybrid joining is the principle of combining different joining technologies. Here, Mechanical fastener and adhesive are used together. Use of a mechanical fastener in hybrid joint is a fail-safe design, but it is an added weight to the structure. Because fastener did not contribute to tensile strength until the adhesive fails. Hence attachments are used to alternate the load paths to the fastener and utilizing the fastener to provide strength to the joint once the joint was loaded. Numerical analysis is carried out to optimize the added curve attachment on conventional hybrid lap joint. Hybrid lap joint with curve attachments of different load transfer angles are designed and analyzed to find a better joint configuration. The analysis results shows that the hybrid joint with the curve attachment of load transfer distance to height ratio of 4 (14 degree) provides the maximum load transfer to the fastener and has the higher strength than other lap joint configurations.

**Key Words:** Hybrid joint, Curve attachment, Single lap joint, Tensile strength, Joining of Composites structures.

## 1. INTRODUCTION

In applications such as aerospace, automobiles, robotic arms composite materials are widely used and attracted extensive attention in past decades. One of the important issues in composite technology is repair of aging of aircraft structures. In such applications and also for joining various composite components together, they are fastened together either using adhesives or mechanical fasteners.

Most conventional hybrid joint designs utilized mechanical fasteners as a fail-safe device on bonded composite joints. The ideas behind the use of these mechanical fasteners were that in an event of an adhesive joint failure, the mechanical fasteners provided additional strength to prevent catastrophic failure of the aircraft structure. However, using the mechanical fastener as a failsafe device meant that the mechanical fasteners were acting as dead weights until a bond failure occurs.

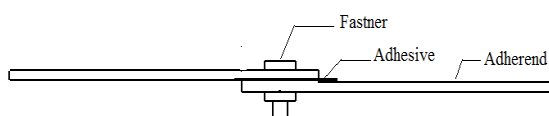

Fig -1: Conventional Hybrid Lap Joint

On an aircraft, unnecessary weight should be avoided at all times. Therefore, a new design was needed to utilize the mechanical fasteners to help provide strength to the joint in addition to acting as a fail-safe device. Hence attachments are used to alternate the load paths to the fastener and utilizing the fastener to provide strength to the joint once the joint was loaded. The amount of load induced in the adhesive joint would be reduced by attachments to increase the overall strength of the hybrid joint.

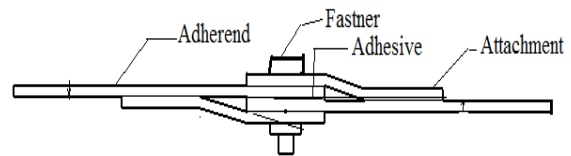

Fig -2: Hybrid Lap Joint with Curve Attachments

The objective of this study is to find a better joint configuration by varying the load transfer angle of the added curve attachment on conventional hybrid lap joint. An in depth discussion and review of studies related to hybrid joints were presented in this section.

Wang and Peng Hao [1] performed an experimental study on the effects of adding attachments in conventional composite hybrid joints on tensile strength. In this research, a new design was proposed where two different types of attachments were used in order to provide alternate load paths to redirect load to the fastener and utilize the fastener to provide strength to the joint once the joint was loaded. Two types of attachments used in this work are a stepped attachment and a curved attachment. In this paper, the improvements in the overall strength of the joint is justified by the experiments conducted with both the conventional hybrid joint and the new hybrid joint design with two different attachments to assess effectiveness of the new design, the more efficient attachment type, and whether the added weight of the attachments. From the tensile testing data collected of the three different types of specimens in this work, the hybrid joints with attachments shows a significant improvement in ultimate tensile strength compared to the conventional hybrid joints. From the data in this research, the hybrid joints with curved attachments show higher ultimate tensile strength and lighter when compared to the hybrid joints with stepped attachments.

C.T. Sun, Bhawesh Kumar, P. Wang and R. Sterkenburg [2] proposed a new hybrid joint design for composite lap joints, which use a small flat piece of composite laminate attachment to create an alternate load path to transfer part of the load from the adherent to the bolt. Experimental investigations in this work revealed that the strength of the new hybrid joint was significantly greater than that of the conventional hybrid joint design. They were also performed two dimensional finite element analyses to provide the explanation of this strength enhancement.

Mugdha V. Bhadak and Prof. A. B. Kakade [3] studied strength and stress distribution of three type of composite joints namely bonded, riveted and hybrid. In this work, various joint like bonded, riveted and hybrid joints are prepared by glass fiber epoxy composite laminates and then undergone for tensile test by universal testing machine with data acquisition system and the hybrid Joint is identified has best by their load Bearing Capacity.

Raviraja.S and L.Nafeez Ahmed [4] studied the strength of three type of composite joints namely bonded, riveted and hybrid both experimentally and in FEA simulation. In this work, Modeling and static analysis of 3D models of the composite joints (bonded, riveted and hybrid) were carried out using FEA software and the results were interpreted in terms of Von Misses stress. From the experimental work in this paper the full potential of composite materials like glass fibre and epoxy as structural elements, the strength and stress distribution of these joints namely, bonded, riveted and hybrid joints must be understood. Various joint like bonded, riveted and hybrid joint were prepared by glass fibre epoxy composite laminates and then undergone for tensile test to find better joint configuration.

After the review of literatures, it has been proposed to use the idea of adding attachments for load transfer in this project to find the optimized lap joint configuration. Curved attachments with different angles are designed to get the optimized single hybrid lap joint configuration from Numerical analysis.

## 2. DESIGN

The dimensions of the joints are taken according to ASTM D5868. The dimensions of the adherents were 25.4 mm wide and 101.6 mm long. The overlap area of the joint was 25.4 mm making the total length of each specimen 177.8 mm long. Two 25.4 mm wide and 25.4 mm long tabs were bonded on the ends of the specimen to provide a grip area for the tensile tester. The mechanical fastener was placed in the middle of the bonding area fastening the attachment and the adherent together. The bolt diameter is chosen to be approximately same as the thickness of the joint. Thickness of the Adhesive Layer is taken as 0.76mm. Table 1 shows the dimensions of the joint as per the ASTM standards.

**Table -1:** Dimensions of the Single Lap Joints

Width of plate	25.4 mm
Length of plate	101.6 mm
Thickness of plates	2.5 mm
Plate overlaps	25.4 mm
Diameter of the holes in plates	5 mm
Diameter of the fastener	5 mm
Diameter of the fastener head	10 mm

The design of a conventional hybrid lap joint with the dimension as per the ASTM standards is shown in Fig.3.

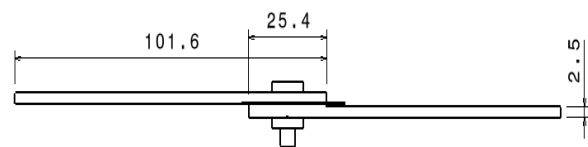

**Fig -3:** Line diagram of Conventional Hybrid Lap Joint

Hybrid lap joint with curve attachment is shown in Fig.4. Two attachments are attached to the conventional hybrid lap joint for the purpose of load transfer to the fastener.

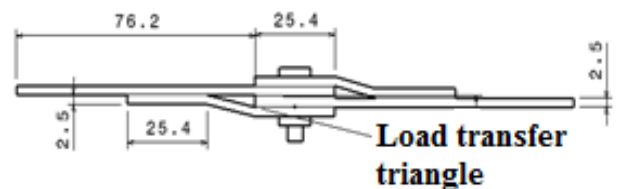

**Fig -4:** Line diagram Hybrid Lap joint with attachments

The adhesive portions of the attachments to both the adherents are equal to the overlap dimension. The angle of the attachment is calculated from the load transfer triangle shown in Fig.5.

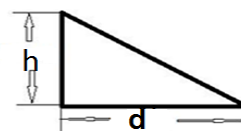

**Fig -5:** Load transfer triangle

The angle of the attachment is calculated as follows.

$$\theta = \tan^{-1} (h/d)$$

Where,

h – Load transfer height

d – Load transfer distance

By varying the load transfer distance of the attachments, different angle of the attachments are calculated as shown in Fig.6.

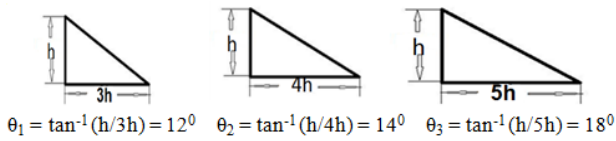

Fig -6: Variations in the load transfer triangle

Thickness of the attachment is taken as equal the thickness of the adherent. The Line diagram of the designed attachment which is attached to the conventional hybrid lap joint for the purpose of load transfer to the fastener is shown in Fig.7.



Fig -7: Line diagram of Attachment

### 3. GEOMETRIC MODEL

The geometric modeling is done in computer aided design package CATIA. The bottom-up assembly design approach is used for modeling. The components are created in the part design workbench. A product file is created and all components are inserted in it using the tools provided in the assembly design workbench. After inserting all components, constraints are applied in 3d space. All dimensions are taken in mm. Fig. 8 shows the front view of the conventional hybrid joints geometric model. Fig. 9 to 11 shows the front view of the hybrid joints with load transfer distance of 3h, 4h and 5h curve attachments geometric model respectively.

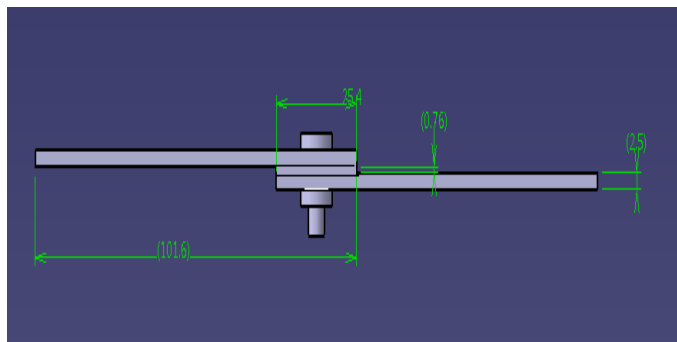

Fig -8: Geometric Model of the Conventional hybrid joint

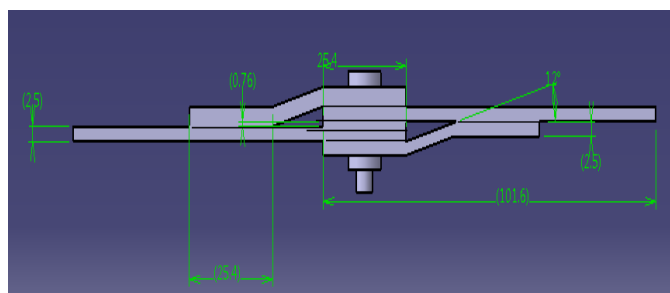

Fig -9: Geometric model of Hybrid lap joint with load transfer distance of 3h curve attachment.

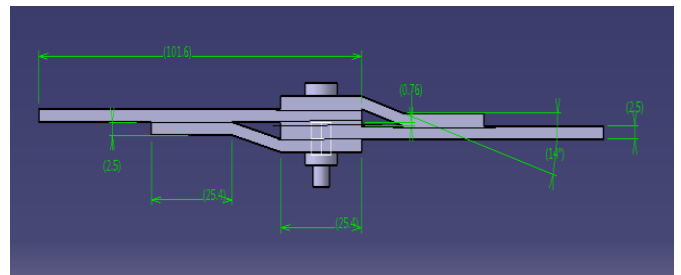

Fig -10: Geometric model of Hybrid lap joint with load transfer distance of 4h curve attachment.

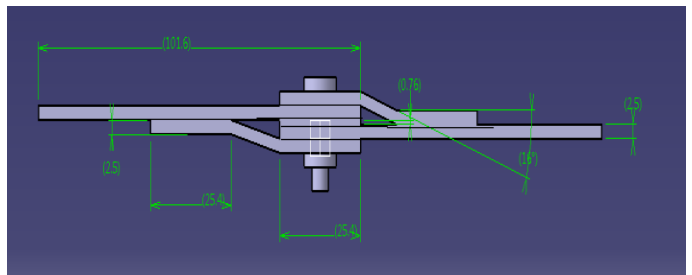

Fig -11: Geometric model of Hybrid lap joint with load transfer distance of 5h curve attachment.

### 4. FINITE ELEMENT ANALYSIS

The simulation of joints is done in finite element analysis package ANSYS. STEP file of the geometric models are imported to ANSYS workbench. The material properties are updated to the material library and corresponding material is assigned to each part of the model. The material of adherent plates, adhesive and fastener are likely Glass/Epoxy composites, Epoxy resin and steel. Contacts between different parts of the joint are assigned and the model is meshed.

The analysis for the joints was performed by applying a tensile load of 1000 N at the end of the joint, which was free to move in the longitudinal direction only (UY = UZ = 0). The opposite end of the joint had fixed boundary condition (UX = UY = UZ = 0).

The Von-Mises criterion is a formula for calculating whether the stress combination at a given point will cause failure. There are three principal stresses that can be calculated at any point, acting in the x, y, and z directions. The Von-Mises criterion is a formula for combining these three stresses into an equivalent stress, often called the Von-Mises stress. Lap shear is the criterion of failure in this case of tension loading on single lap joint. Shear stress and Equivalent stress of each joint configuration is obtained from the finite element analysis. Fig. 12 shows the shear stress of the conventional hybrid joint. Fig. 13 to 15 shows the shear stress of the hybrid joints with load transfer distance of 3h, 4h and 5h curve attachments respectively.

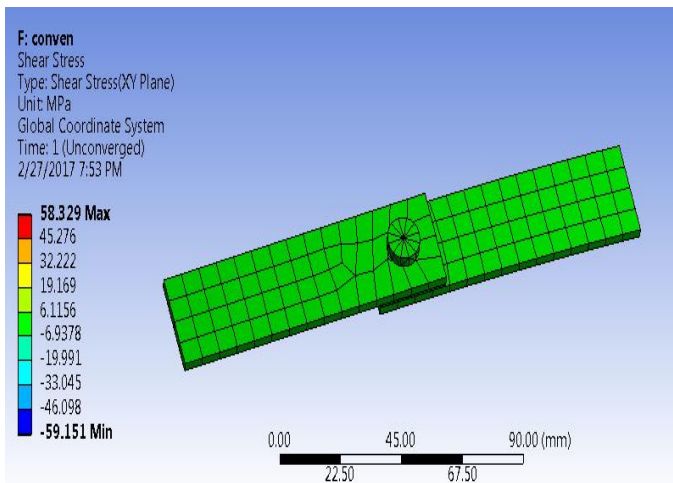

Fig -12: Shear stress of Conventional hybrid lap joint

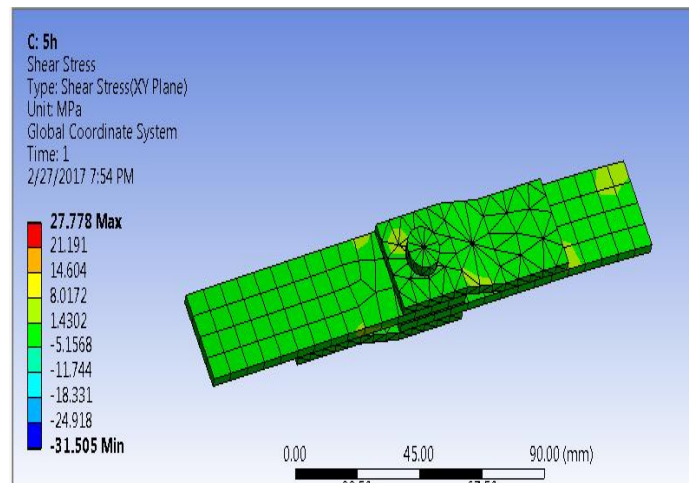

Fig -15: Shear stress of hybrid lap joint with load transfer distance of 5h curve attachment

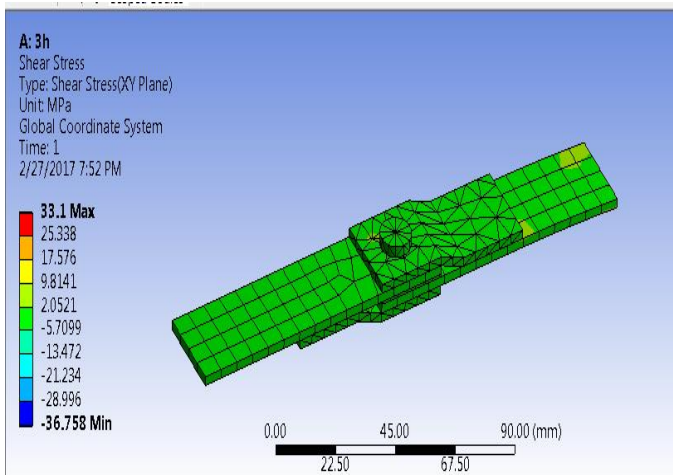

Fig -13: Shear stress of hybrid lap joint with load transfer distance of 3h curve attachment

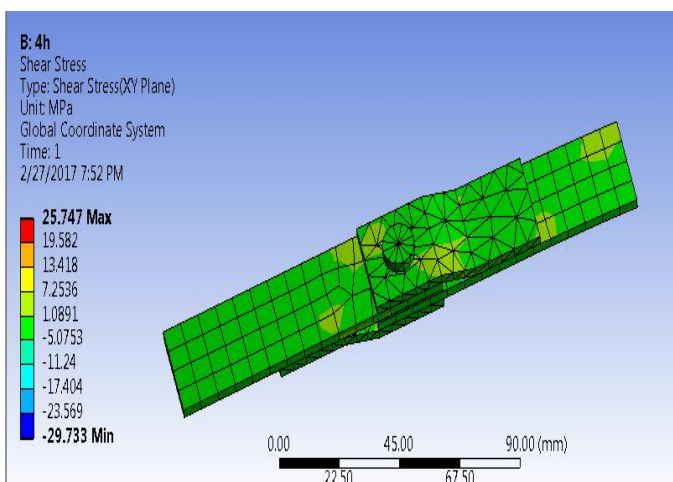

Fig -14: Shear stress of hybrid lap joint with load transfer distance of 4h curve attachment

### 5. RESULT AND DISCUSSION

Comparison of Shear stress and Equivalent stress of different joint configuration from the finite element analysis are shown in chart 1 and 2. Chart 1 shows the reduction in shear stress is very high in hybrid joint with attachments than in the conventional hybrid lap joint. This drastic reduction in stress shows the increase in strength is very high with a minimum added weight to the conventional hybrid lap joint.

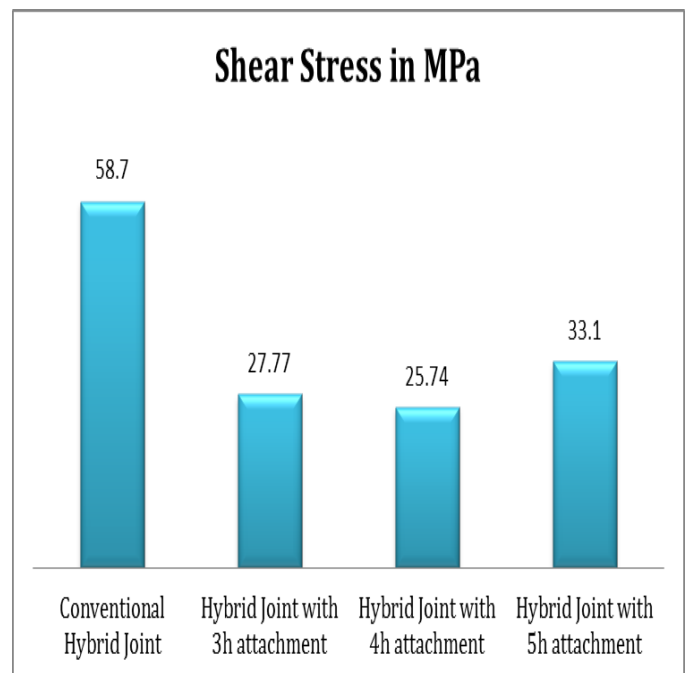
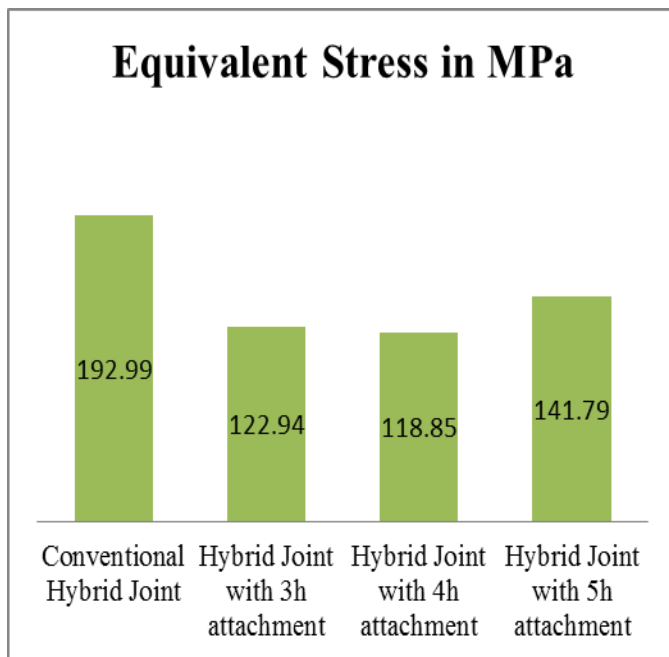

Chart -1: Shear stress of different joint configuration



**Chart -2:** Equivalent stress of different joint configuration

The comparison charts from the finite element analysis results shows clearly that the hybrid joint with the curve attachment of load transfer distance to height ratio of 4 (14 degree) provides the maximum load transfer to the fastener and reduced the stresses acting in the joint.

## 6. CONCLUSIONS

The objective of this study is fulfilled from the new design of single lap joint configuration which has drastic increase in strength with minimum added weight. Hybrid lap joint with curve attachment of load transfer distance to height ratio of 4 (14 degree) has higher tensile strength than other joint configurations. It provides the maximum load transfer to the fastener and decreases the induced load in adhesive to increase the overall load carrying capacity of the joint. Its increase in weight is also acceptable because of its drastic reduction in stress. It is applicable to use this optimized new joint configuration in the structures like aerospace, automobiles and robotic arms which are in need of more factor of safety and weight considerations.

## REFERENCES

- [1] Wang and Peng Hao, 'The Effects of Adding Attachments in Conventional Composite Hybrid Joints on Tensile Strength', College of Technology Directed Projects, Paper 29, 2010.
- [2] C.T. Sun, Bhawesh Kumar, P. Wang and R. Sterkenburg, 'Development of Improved Hybrid Joints for Composite Structures', Federal Agency of Aviation Research Publication for the JAMS Center of Excellence.
- [3] Mugdha V. Bhadak and Prof. A. B. Kakade, 'Performance and Analysis of Bonded, Riveted, Hybrid Joint - A Review', International Journal for Research in

Emerging Science and Technology, Volume-3, Issue-1, 2016.

- [4] Raviraja.S and L.Nafeez Ahmed, 'FEA and Experimental Evaluation of Bonded, Riveted and Hybrid Joints in Glass Fibre Epoxy Composite Laminates', International Journal of Innovative Research in Science, Engineering and Technology, Volume 4, Special Issue 3, 2015.
- [5] Prachi Dixit and Satish S Kadam, 'Hybrid Joint for Automotive Composite Structures'.
- [6] S.Venkateswarlu and K.Rajasekhar, 'Design and Analysis of Hybrid Composite Lap Joint Using Finite Element Methods', International Journal of Engineering Trends and Technology, Volume 4, 2013.
- [7] F. Mustapha, N. W. Sim and A. Shahrjerdi, 'Finite element analysis (FEA) modeling on adhesive joint for composite fuselage model', International Journal of the Physical Sciences, Vol. 6 (22), 5153-5165, 2011.
- [8] Jin-Ha Park and Kang-Woo Jeong, 'A Study on Failure Strength Evaluation of Hybrid Composite Joint', 18th International Conference on Composite Materials, National Research Foundation of Korea (NRF) funded by the Ministry of Education, Science and Technology, 2010.
- [9] Gang Li, Ji Hua Chen, Marko Yanishevsky and Nicholas C. Bellinger, 'Static strength of a composite butt joint configuration with different attachments', Composite Structures, www.elsevier.com/locate/compstruct, 2011.
- [10] Mechanics of Composite Materials by AUTAR K. KAW.