

Data Transmission through Inductive Coupled System

¹Prajakta P. Dumbre, ²Mr. S.T. Valunjkar, ³Mr. Shrikant Bagul, ⁴Mr. Ashish Prabhu

¹Mtech (Electronics & Design Technology)

National Institute of Electronics and IT, Aurangabad

²Scientist/Engineer 'D', National Institute of Electronics and IT, Aurangabad

³Director, ⁴Senior Engineer, Inavit Systems Private Limited, Pune
Pune, Maharashtra, India

Abstract - This paper presents a data and power transmission using inductive coupling of two coils. This system optimizes power efficiency of overall transmission using amplifiers and inductive link. This system is designed using two Nano power microcontrollers and dual circuits for redundancy. Pulse amplitude modulation for data and power transfer. Data Transmission is designed for applications in military where radio or infrared data transmission is not possible. System is safe and reliable for initiating commands on time and impact basis.

Key Words: Fuze, Fuze Setter, Inductive Link, Transmitter coil, Receiver coil.

1. INTRODUCTION

Technological advances over the year have made it possible to reduce the size and power consumption of electronics. Wireless energy transmission can eliminate the need for cables and connectors in any equipment. It is the ideal solution when little board space is available. This system is designed for military applications where time adjustment is very accurate and refers MIL standards. Time fuzes detonate after a set period of time by using one or more combinations of mechanical, electronic, pyrotechnic or even chemical timers. Objective of the system is to create an inductively coupled system for power and data transmission in Fuze. Data Transmitted in this system is only time. The time can be set with help of inductive coupling system using data and power transfer with help of high frequency pulse amplitude modulation (PAM). The circuit will be designed keeping in mind that all the qualification tests will be carried out as per MIL standards.

1.1 Inductance

Inductance is a measure of how much energy is stored in magnetic fields when a current is flowing along a path. Two types of inductance can be defined, mutual inductance and self-inductance. The self-inductance is the inductance of a path with itself, and can be defined as $\Phi = LI$, where Φ is the total magnetic flux passing through any surface with the path as the boundary. The mutual inductance is a measure of the total flow of magnetic flux

from one current carrying path that passes through another closed path. The mutual inductance can also be described as $M = k\sqrt{L_1L_2}$, where k is the coupling coefficient. The mutual inductance is one of the most important parameters when designing an inductive power transfer system [3].

1.2 Inductive links

In circuit theory, induction is modelled by $u = L \frac{di}{dt}$ for a single inductor. For two coupled inductors with the resistance and parallel capacitance neglected, the model used is:

$$[u_1 \ u_2] = [L_1 \ M \ M \ L_2] [di_1 \ dt \ di_2 \ dt] \quad (1.1)$$

This setup is usually used as a transformer with a coupling coefficient k very close to 1. It transfers power from one inductor to the other efficiently only if $k \approx 1$. However it is impossible to achieve a coupling coefficient close to 1 when the distance between the coils is large [3]. Inductive power links are based on two inductive coupled coils. These coils are placed in near field can be modelled using Maxwell equation.

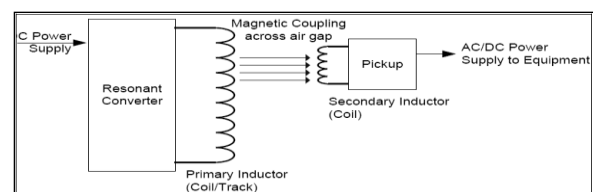

Fig -1: Inductive Power Link

2. Inductive Power Transfer System

This section discusses the IPT by inductive coupling. It explores the IPT transformer concept then it investigates the resonant circuits, which are mainly four types (based on the resonant circuit); series-series (SS), series-parallel (SP), parallel-series (PS), and parallel (PP). It is represented by two letters S for series and P for Parallel, the first letter represents transmitter side and second part represents the receiver side [4]. The design consists of a Transmitter station containing a parallel resonant converter and a tuned pickup circuit at receiver side.

Setting is provided at transmitter unit to accommodate load changes at receiver end. The system has two fold operations; first power will be transmitted and capacitor will be charged at receiver end to energize data storage circuit that is, the memory will be energized. Then data will be transmitted, which will be retrieved and stored in the memory at the receiver side. Inductive Power Transfer (IPT) refers to the concept of transferring electrical power between two isolated circuits across an air gap. Recently IPT has been developed into working systems. The primary side of the system is made up of a resonant power supply and a coil. This power supply produces a high frequency sinusoidal current in the coil. Transmitter consists of power amplifier (PA) circuit and an antenna coil L1. The transmitter antenna coil is tuned to resonance with tuning capacitor C1. Receiver consists of an antenna coil L2, a tuning capacitor C2 and rectifier and regulator part.

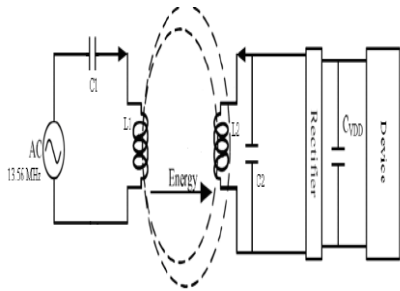

Fig -2: Inductive power transfer system

The receiver’s ability to efficiently draw energy from the reader field is based on the well-known electrical resonance effect. Antenna element has to be designed to resonate at system operating frequency.

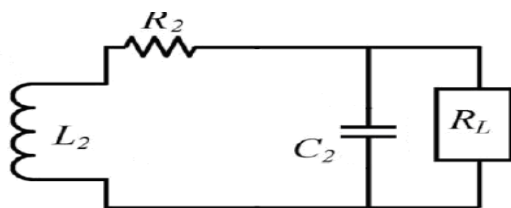

Fig -3: Receiver Circuit

3. System Architecture

Inductive Setting is divided in to two parts:-

- 1) Fuze circuit for time setting.
- 2) Fuze Setter Circuit

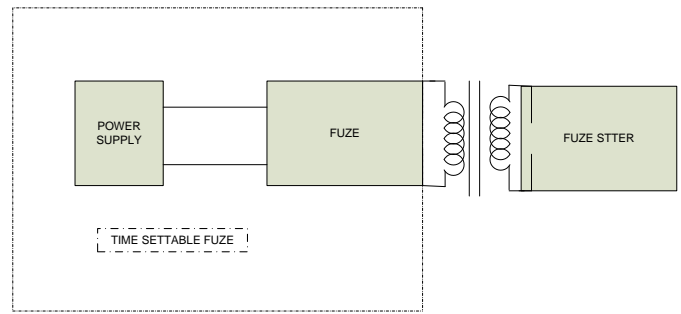

Fig -4: Concept Diagram

3.1 Fuze circuit for time setting

Sine wave is generated by the fuze-setter is received by the coil in this circuit which is located in the fuze. This sine wave is then rectified to convert it into DC voltage. This DC voltage is then given to the Regulator part of the circuit to drive the microcontroller and comparator.

The output of the rectifier is given to the comparator to get switching pulses related to set time which are further given to microcontroller and according to the set time firing pulse are given. For read cycle, a transistor is used in accordance with microcontroller where the microcontroller sends pulses to the transistor which switches the transistor ON and OFF. This transition will be sensed at the setter side

A voltage regulator is used to sense the Power On state. When On the output DC voltage generated by the power supply is converted to 5V which is sensed by the microcontroller and this voltage is been utilized by the microcontroller.

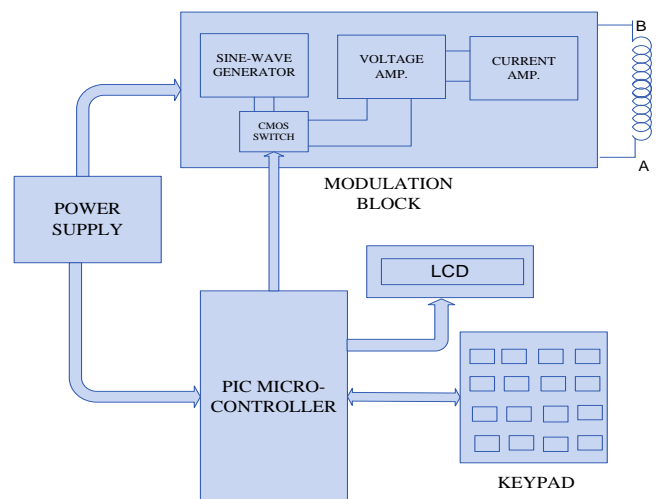

Fig -5: Block Diagram of inductive system

A feedback section is used to give feedback during the read cycle. This feedback is sensed by the fuze setter and corresponding timing is displayed on the fuze setter screen. The protocol enables the microcontroller to store the timing in the non-volatile (i.e. EEPROM) memory of the micro-controller at Fuze end during the Write cycle. Since both ends of system that is Fuze setter and Fuze end has micro-controller a special protocol is required to communicate.

Dual Micro-controllers are used in the fuze for the redundancy. One controller communicates with the fuze setter while other detonates the firing circuit or de activates it. One controller is powered up only by fuze setter while other uses the battery backup.

3.2 Fuze Setter Circuit

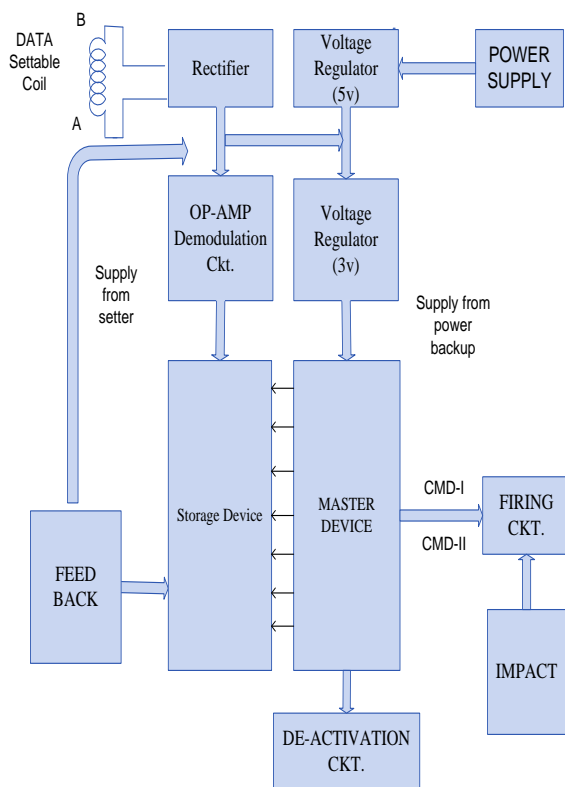

Fig -6: Block Diagram of Fuze Setter

The Fuze setter is divided into three functional blocks:-

- 1) PIC micro-Controller & Its peripherals (LCD and Keypad)
 - 2) Modulation Section
 - 3) Power supply Section
- PIC controller and its Peripherals are used for the user interfacing. Using the keypad user can feed timing into the system and while doing so can see it on the LCD. A protocol is defined for the communication between Fuze setter and the Fuze.

- 16*2 LCD: - A new type of display is used to display operations of fuze setter. This type of display has better visibility in the darkness as well as in the bright sun light. It consumes very less power and makes the fuze setter highly energy efficient which is pre-requisite since setter works on the battery back-up.
- 4X4 Matrix keypad: - The keypad used is a tactile 4*4 matrix keypad for time setting in between 6.0 sec to 199.9 sec. It also has separate switches for Write and Read operations.

- Modulation section consists of the Sine wave generators, Voltage amplifier and current amplifier.

Sine wave Generator: - Its continuously generates the sine wave. It gives input to the CMOS switch. The gate of the CMOS switch is controlled by the micro-controller. Sine wave is generated on pin no 2 with peak to peak voltage of 3Vp-p using ICL8038.

Voltage and Current amplifier: - Since the voltage and current levels aren't sufficient to communicate they are needed to be up lifted. Hence this section is included in the Modulation section. An Op-amp IC amplifies voltage to 24Vp-p. This voltage is later given to the emitter follower to increase the current that is going to flow through coils (Q3 and Q4).

- Power supply: - Power supply section has LM 7805 IC which regulates voltage and ICL7660 IC to generate negative voltage. 18V required voltage for the circuit is provided by the batteries and because of ICL 7660 we won't need another source for negative supply. Sine wave IC voltage levels are achieved by this.

5. CONCLUSION

In this paper, an inductive power transfer and data transfer for Military application is proposed. Besides the power transfer, data is also transferred wirelessly with the power in order to set time in fuze and initiate command on time and impact basis.

REFERENCES

- [1] B. Lenaerts and R. Puers, "An inductive power link for a wireless endoscope," *Biosensors and Bioelectronics*, vol. 22, no. 7, pp. 1390–1395, 2007.
- [2] Madawala, U.K.; Thrimawithana, D. J., "Current sourced bidirectional inductive power transfer system," *Power Electronics, IET* , Vol. 4, no. 4, pp. 471,480, April 2011.
- [3] S. Asheer., A. Al-Marawani., T. Khattab.,A. Massoud., "Inductive Power Transfer with wireless Communication system for electrical Vechiles", *IEEE GCC conference* November 2013.

- [4] "Design of Wireless Power Transfer and Data Telemetry System for Biomedical Applications"
Ashraf Bin Islam University of Tennessee.
- [5] N. Tesla, "Apparatus for Transmitting Electrical Energy," U.S. Patent, 1902.

BIOGRAPHIES

Prajka Pandurang Dumbre
Mtech (Electronics & Design
Technology)
National Institute of Electronics &
IT, Aurangabad
prajudumbre@gmail.com