

# Design Methodology of Steering System for All-Terrain Vehicles

Dr. V.K. Saini\*, Prof. Sunil Kumar”  
Amit Kumar Shakya<sup>#1</sup>, Harshit Mishra<sup>#2</sup>

\*Head of Dep't of Mechanical Engineering, IMS Engineering College, Ghaziabad (U.P.), India

”Professor, Dep't of Mechanical Engineering, IMS Engineering College, Ghaziabad (U.P.) India

# UG Scholar, IMS Engineering College, Ghaziabad (U.P.), India

**Abstract-:** This Study named “Design Methodology of Steering System for All-Terrain Vehicles” is to ensure the most efficient steering assembly selection for an All-Terrain Vehicle. In this process various parameters are kept in mind for an effective selection of Steering system. The Steering system uses a Rack and pinion gearbox for Steering along with this Ackerman geometry is being used for the steering assembly. In this assembly modified Column of Tata Nano car is used which is connected to Rack and Pinion Gearbox by a Universal Joint. The Steering wheel is so designed to meet the weight reduction requirement along with keeping in mind the driver comfort. The Rack and pinion gearbox is connected with Steering arm by the Tie Rods. Tie Rods and Steering arm are being designed and analyzed for their load bearing Capacities.

**Keywords -:** Rack and Pinion Gearbox, Ackerman Steering Geometry, All-Terrain Vehicle, Tie Rods, Steering arm

## 1. Introduction

The design of steering system has an influence on the directional response behavior of a motor vehicle. The function of the Steering system is to steer the front wheels in response to driver inputs in order to provide overall directional control of the vehicle. However, the actual steering angles are modified by the geometry of the suspension system, reactions and the geometry of the steering system and the reactions of Powertrain if the vehicle is front wheel drive.

The rack and pinion system has gained popularity for the passenger cars as well as for the because of the advantages like a simpler design and better suitability of front wheel drive system and adaptability to vehicles without frames. The Gearbox is the primary means for the numerical reduction between the rotational input from the steering wheel and rotational output about the steering axis. The steering wheel to road wheel angle ratios normally vary with the angle, but have a general value of the order of 15:1 for

commercial passenger cars to 4:1 for racing cars. Initially, all Rack and Pinion systems are available that have fixed ratio and any changes in the ratios are obtained by changing the geometry. Today, rack and pinion systems are available that can vary their gear ratios directly with steer angle.

The lateral acceleration produced by the gearbox is relayed through linkages to steering arms on the left and right wheels. The kinematic geometry of the relay linkages and steering arms is usually not a parallelogram (Which would produce equal left and right steer angles), but rather a trapezoid to more closely approximate “ Ackerman” geometry which steers inner wheel to greater angles than outer wheels while turning.

## 2. Methodology

The Process followed for design and fabrication of Steering system involves following steps.

1. Analysis of Previous year's Vehicle
2. Defining the Objective for New vehicle.
3. Market Survey for the Components used.
4. Steering Geometry Iterations.
5. Design Validation.
6. Steering system parts fabrication.
7. Steering system Assembly.

### 1. Analysis of Previous Year's Vehicle

STEERING PARAMETERS (2016)	
LHD OR RHD	CENTER
STEERING RATIO	17:1
TURN LOCK TO LOCK REVOLUTION	3.5rev
GEOMETRY	ANTI- ACKERMAN
COLUMN	TATA NANO STEERING COLUMN
RACK AND PINION	TATA NANO RACK AND PINION
STEERING WHEEL DIAMETER	14 INCHES

Table -: 1 Previous Year's Steering Parameters

### 2. Objective for New Vehicle

- Outer Turning Radius -: 2.5m
- Lesser Lock to Lock rotation
- Lower Steering ratio.
- Modified Column for weight reduction.
- Ackerman Steering Geometry.
- Optimized steering wheel dimension for driver comfort.

### 3. Market Survey

After doing market Surveys following Components were selected for the steering system.

- Customized Rack and Pinion Gearbox.(10:1)
- Modified Tata Nano Steering Column.
- Stainless Steel Pipes for Tie rods.

S.no	Parameters	Value
1	Rack Size	15 inches
2	Rack size (eye to eye)	14 inches
3	Travel centre to lock	2.24 inches
4	Travel lock to lock	4.48 inches
5	Pinion Radius	0.53 inches

Table -: 2 Rack Parameters

### 4. Steering Geometry

The Ackerman steering geometry is selected for the vehicle because this geometry enables the vehicle to turn about the

common centre i.e. without skidding of the tires and also the Ackermann geometry is favored for the slow speed vehicle as the speed limit for the vehicle we are designing is 60 km per hour so it's the obvious choice. This geometry provides excellent control for low-speed maneuvering.

Vehicle Design Parameters	
WHEELBASE	65 inch
TRACKWIDTH	55 inch
RACK LENGTH	14 INCHES FROM CENTRE TO CENTRE OF ROD END
GROUND CLEARANCE	15 INCHES
KPI TO KPI DISTANCE	46.7 INCHES
SCRUB RADIUS	11 cms

Table-: 3 Vehicle Design Parameters

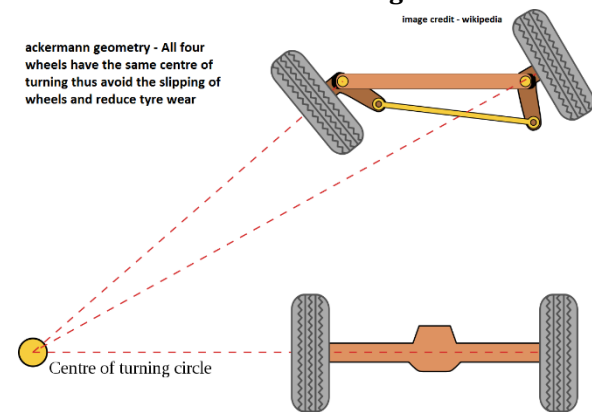

Figure -: 1 Ackerman geometry

In Ackerman geometry the inside wheel turns more than the outside wheel [3]. In this geometry, the rack is placed behind the front axle and if we extend the steering arms then they will meet at the extension of rear axle during turning, the point is the instantaneous center about which the whole vehicle turns without skidding [3].

#### 4.1 Inside and Outside Steering Angle

As the requirement for our vehicle is to keep turning radius low so it is decided that the outside turning radius of our vehicle should be 3 meters.

$$R = \frac{b}{\sin \phi} + \frac{a-c}{2}, \text{ (By geometry Figure 3) (i)[1]}$$

$$3000/25.4 = \frac{65}{\sin \phi} + \frac{55 - 46.7}{2}$$

$$\Phi = 34.77 \text{ deg.}$$



Fig -: 2 Rack and pinion

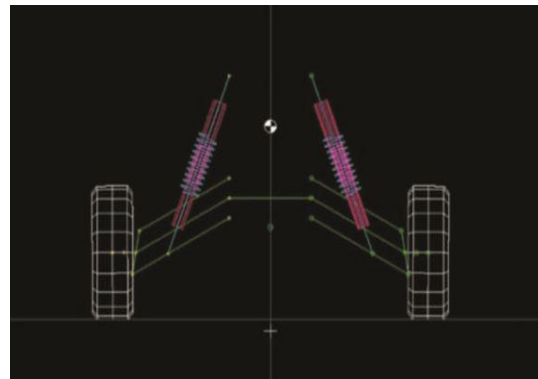

Figure-: 4 Front View of steering system

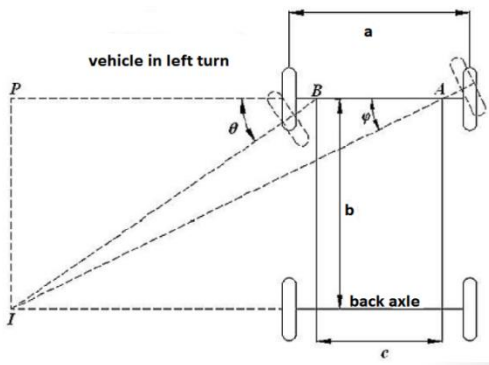

Figure- : 3 Vehicle in turn IA is turning radius

Now by correct steering geometry,

$$\cot \phi - \cot \theta = \frac{c}{b} \quad (ii)[1]$$

$$\cot 34.77 - \cot \theta = \frac{46.7}{65}$$

$$\theta = 54.17 \text{deg.}$$

$$\text{Total steering angle} = 34.77 + 54.17 = 88.9 \text{deg}$$

### 4.2 Steering Ratio

This is defined as ratio of angle turned by steering wheel in lock positions to the sum of total steering angle of tires [3] so,

$$\begin{aligned} \text{Total angle turned by steering wheel} \\ &= \text{track width} / (2 * 3.14 * \text{pinion radius}) \\ &= 4.48 / (2 * 3.14 * .53) = 484.33 \text{deg.} \end{aligned}$$

$$\text{Steering ratio} = 484.33 / 88.9$$

$$\text{Steering ratio} = 5.44: 1$$

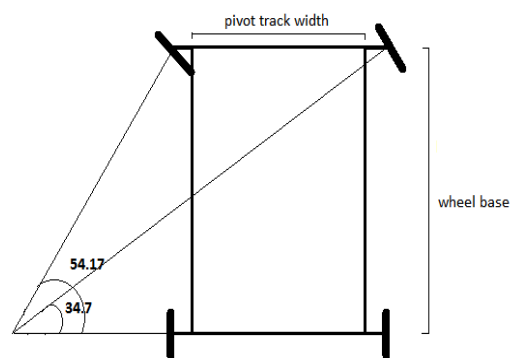

Figure -: 5 Vehicle steering angle

### 4.3 Position of rack

After several iterations for Placement of rack on LOTUS Simulation software according to the requirement of steering angles, we came to following data for positioning of rack.

Rack Height -: 46 cm from Ground

Rack from FBM -: 3 inches

Steering arm length from KPI to Pivot Point = 4.3 inches

$$\text{Ackerman angle} = \frac{\text{KPI to KPI Distance}}{2 * \text{Wheelbase}}, \quad (iii) [1]$$

$$\text{Ackerman Angle} = \frac{46.7}{2 * 65} = 19.75^\circ$$

Ackerman Percentage= 91%

(This is calculated in LOTUS)

Rack travel = 4.48 inches from lock to lock.

### 4.4 Tie Rod Length

Steering Arm Length = 4.3”

(After various iterations on lotus and manually to achieve the required angles)

Distance between IBJ and OBJ horizontally is = 23.35 – 1.5 – 7 = 14.85”

But the tie rods are not in the plane of steering arm, tie rods inclined at an angle of 17deg downwards from horizontal and 5deg towards forward i.e. tie rods are not parallel to front axle.(as per the design of vehicle)

Therefore, the length of tie rods is

$$14.9 / (\cos 17^\circ \cos 5^\circ) = 15.64''$$

The suspension arms used in the vehicle are parallel to each other and are of equal length i.e. the I Centre of the arms are at infinity,

To reduce the bump steer the tie rods must be parallel to suspension A-arms so that during the bump the I-Centre of tie rods also meets the I-Centre of A-arms at infinity. In this way the arc traveled by tie rods and the arms were equidistant to each other during the travel of suspension and there was no force generated along the rack to produce bump steer.

### 4.5 Determination of Steering Effort

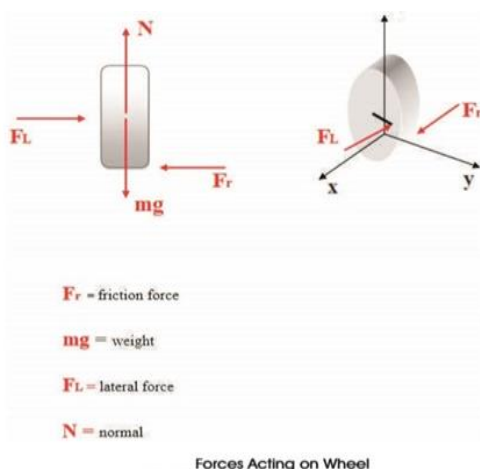

Figure:- 6 Forces on tire

Steering effort is defined as the effort to be made by the driver in turning the steering wheel. This can be calculated in either static condition i.e. when the vehicle is stationary and in dynamic conditions. Steering effort is maximum when the vehicle is stationary.

Mass of vehicle = 223+70 (with driver of 70kg)

Mass of Vehicle = 293 kg.

Mass acting on Centre of gravity = 258.44

Taking moment about B (in Figure 09)

$$258.44 * 26.93 = R_A * 65$$

$$R_A = 1050.39 \text{ N}$$

Reaction at each tire

$$(R_A/2 + \text{mass of tire}) * 9.81$$

$$= 1050.39/2 + 8.14 * 9.81$$

$$= 605.04 \text{ N}$$

When the car is stationary, the forces in all directions are in equilibrium (Figure 7)

$$\Sigma F_x = 0; F_L = F_R \tag{1}$$

$$\Sigma F_y = 0; N = mg \tag{2}$$

The tires used for the vehicle are mud tires and coefficient of friction between tires and rolled gravel ground is 0.6 (data provided by various tire manufacturers)

The friction force at the tire is

$$= \mu * \text{Reaction at each tire}$$

$$= .6 * 605.04$$

$$= 363.024 \text{ N}$$

While turning the steering wheel the torque will transmit to pinion and then to the steering arms and this torque should be equal or greater than the frictional resistance of the ground to be able to turn the tire.

From this, the value of steering arm torque is calculated by multiplying length of steering arm with the friction force  $F_R$ .

$$\text{Steering Arm (SA) torque} = 363.024 * .11 = 39.93 \text{ N-m}$$

Force perpendicular to steering arm ( $F_{S1}$ )

$$F_{S1} = 39.93/0.11 = 363 \text{ N}$$

Since tie rod is not in the plane of steering arm and it's also not parallel to front axle so components of this force is taken

Therefore, component of force below tie rod in the plane of steering arm is  $F_{S2}$

$$F_{S2} = F_{S1}/\cos 24.75 = 399.71 \text{ N}$$

Tie rod is at an angle of 17deg above from the plane of  $F_{S2}$  (According to rack placement and steering arm plane)

$$F_{ST} = F_{S2}/\cos 17 = 403.31 \text{ N}$$

Force along rack ( $F_{rack}$ )

$$F_{rack} = F_{ST}/\cos 17 = 421.73 \text{ N}$$

Torque acting on the pinion

$$= F_{rack} * \text{radius of pinion}$$

$$= 421.73 * 13.47 * 10^{-3}$$

$$= 5.68 \text{ N-m}$$

**Torque on steering wheel = Torque on pinion**

Steering wheel torque = 5.68 N-m

The amount of force or effort required on the steering wheel is calculated by dividing the torque by the radius of steering wheel

**Steering effort = 5.68 / (0.127)**

**Steering effort = 44.72 N**

This is the force when applied by the driver will turn the tire in static condition; the effort required in dynamic condition will be less than static effort.

#### 4.6 Nature of Steering (Oversteer or Understeer)

**Oversteer** – Oversteer is the condition when the vehicle at the time of cornering steers more than the angle provided by the driver through steering wheel. This happens when the rear tires losses their traction before the front tires because of the centrifugal force acting on them. When rear tires

losses their traction and they slip out of the corner thus inducing more steer to the vehicle. (Figure 8)

**Understeer** – this condition appears when the front tires losses their traction before the rear tires and slip out of the turn during cornering at large speeds and smaller curves. In this case, the vehicle follows a larger curve for cornering then it actually should. In Understeer, the driver needs to steer the vehicle more than the required angle for making the turn.

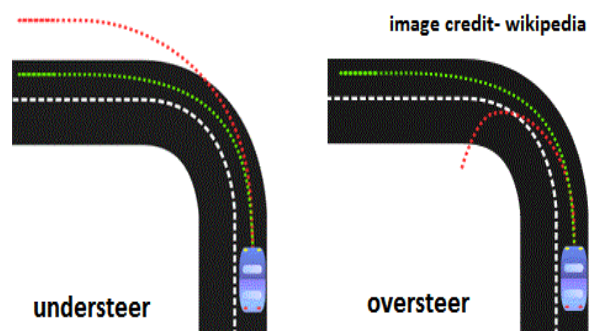

Figure-: 7 Oversteer and Understeer

Whenever the vehicle is taking a turn an outward lateral force act on the vehicle due to centrifugal effect also called as the cornering force.

Sum of lateral forces is equal to mass of vehicle time's centripetal acceleration.

$$\text{Cornering force} = M * V^2 \tag{iv} [3]$$

$F_{YF}$  = Rear axle lateral force

$F_{YR}$  = front axle lateral force

$$F_Y = F_{YF} + F_{YR} \tag{3}$$

Calculation at 2.5m radius and 25 km/h speed i.e. 6.944 m/s.

$$F_Y = 223 * 6.944 * 6.944 / 2.5$$

$$F_Y = 4301.14 \text{ N}$$

Sprung mass of vehicle = 210 kg

Sprung mass at front axle and rear axle

$$M_f = 210 * \frac{c}{b}$$

$$M_r = 210 * \frac{c}{b}$$

Using above equations

$$M_f = 87 \text{ kg}$$

$$M_r = 122.99 \text{ kg}$$

At fixed radius of 2.5m and different velocities values of  $F_{YF}$  and  $F_{YR}$  are as follows

At  $v=6.99 \text{ m/s}$

$$F_{YF} = 1700 \text{ N}$$

$$F_{YR} = 2403.72 \text{ N}$$

Now Average values

$$F_{YF} = 742.06 \text{ N or } 168.07 \text{ lbs.}$$

$$F_{YR} = 1049.136 \text{ N or } 237.62 \text{ lbs.}$$

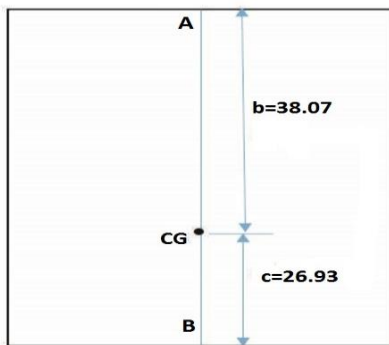

Figure -: 08 CG from rear and front axle

At  $v = 0 \text{ m/s}$

$$F_{YF} = M_f \cdot V^2 / R = 0$$

$$F_{YR} = M_r \cdot V^2 / R = 0$$

Similarly,

At  $v = 1.39 \text{ m/s}$

$$F_{YF} = 67.23 \text{ N}$$

$$F_{YR} = 95.05 \text{ N}$$

At  $v = 2.78 \text{ m/s}$

$$F_{YF} = 268.94 \text{ N}$$

$$F_{YR} = 380.2 \text{ N}$$

At  $v = 4.16 \text{ m/s}$

$$F_{YF} = 602.23 \text{ N}$$

$$F_{YR} = 851.36 \text{ N}$$

At  $v = 5.55 \text{ m/s}$

$$F_{YF} = 1071.92 \text{ N}$$

$$F_{YR} = 1515.35 \text{ N}$$

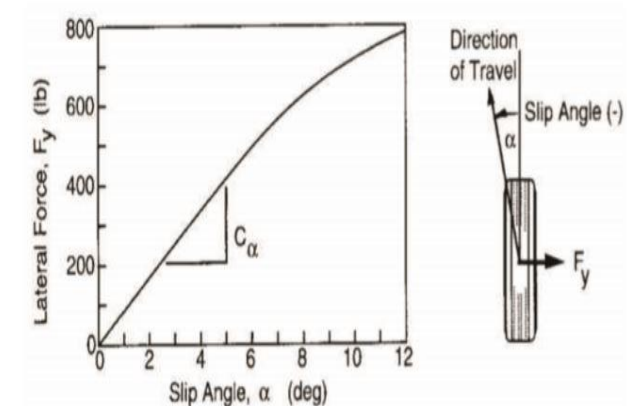

Figure -: 9 Lateral Force vs. Slip Angle Graph [3]

From the above graph [3] the values of slip angle is interpolated as

$$\alpha_f = 1.73 \text{ deg}$$

$$\alpha_r = 2.5 \text{ deg}$$

Cornering stiffness ( $C_\alpha$ )

$$C_\alpha = \frac{f_y}{\alpha} \tag{v}[3]$$

$$C_{\alpha_f} = 742.06 / 1.73 = 428.93 \text{ N/deg}$$

$$C_{\alpha_r} = 1049.136 / 2.5 = 419.65 \text{ N/deg}$$

$$\text{Weight on front axle } (W_f) = M_f \cdot 9.81 = 853.47 \text{ N}$$

$$\text{Weight on rear axle } (W_r) = M_r \cdot 9.81 = 1206.53 \text{ N}$$

**Oversteer condition**

If  $\frac{W_r}{C_{\alpha_r}} > \frac{W_f}{C_{\alpha_f}}$  [3] then vehicle will Oversteer otherwise it will have a tendency of Understeer.

$$\frac{W_r}{C_{\alpha_r}} = 2.875, \quad \frac{W_f}{C_{\alpha_f}} = 1.99$$

Since the value satisfies the condition of oversteer, therefore the vehicle has the tendency of oversteering at cornering.

#### 4.7 Required Angle at the time of maximum turn

Velocity (m/s)	FYF (N)	Slip Angle(deg)	Required angle(deg)
0	0	0	54.17
1.39	67.23	0.16	54
2.78	268.9	0.7	53.4
4.167	602.2	1.5	52.67
5.55	1071.9	2.7	51.47
6.94	1700	3.96	50.21

**Table-: 4 Required Internal Wheel Steer Angle at Maximum Turn at Different Speeds.**

Above table shows, that at the time of sharp cornering the vehicle is oversteering i.e. the rear tires loss their traction before front tires and slip angles are induced and required angle for maximum turning reduces because the vehicle is steering more than the driver’s feed at the steering wheel.

#### 4.8 Materials used for different steering parts

S.no	Component	Material
1	Steering arm	Hardened mild steel
2	Tie rods	Stainless Steel- 304
3	C-Clamp	Stainless Steel - 304
4	Rack	Al- Alloy
5	Steering column	Stainless Steel

**Table-: 5 Materials Used for Different Parts**

#### 5. Conclusion

The objective of designing effective steering system for an all-terrain vehicle is accomplished with the application of engineering principles and with the use of Simulation Software like LOTUS, The vehicle’s steering system was designed for optimal performance. The Design is validated in dynamic conditions and effective changes are done with improvements in design we have achieved a steering ratio of 5.5:1 which is better than our objective of 8:1 and great improvement from previous steering ratio. The Steering system is so designed to minimize the bump steer and we are able to achieve this. Bump steer in the vehicle is almost negligible.

Steering system involves many factors and other parameters of the vehicle such as suspension, weight distribution, and transmission system used. All of these should be kept in mind while calculation is done. Steering system optimization is highly iterative in nature where different iterations are performed on softwares and manually before deciding the best solution, which fulfills the vehicle requirement and objective.

Calculation of steering involves a lot of unknown variables and that is why we need to assume certain parameters about the geometry and then perform the iterations and check if the assumption of the system meets the objective or not.

Based on the requirements and performance of the vehicle the way of calculations can vary and should meet the objective.

This paper shows the method we used to calculate the values for our vehicle according to our vehicle design and we meet the entire objective we set for our vehicle.

#### 7. References

- [1] G.B.S. Narang – Automobile Engineering
- [2] Carroll Smith – Tune to Win
- [3] Thomas D Gillespie – Fundamentals of Vehicle Dynamics
- [4] William F. Milliken and Douglas L. Milliken -: Race Car Vehicle Dynamics; ISBN 1-56091-526-9
- [5] Dhiraj Malu, Nikhil Katare, Suraj Runwal, Saurabh Ladhe, Design Methodology for Steering System of an ATV. International Journal of Mechanical Engineering and Technology, 7(5), 2016, pp. 272–277