

## Design and Fabrication of Hyacinth Remover

Prasad V. Shastri<sup>1</sup>, Abhishek V. Bende<sup>2</sup>, Devendra V. Chopade<sup>3</sup>, Sagar T. Ubhe<sup>4</sup>, Prof. Dilip P. Borse<sup>5</sup>

(Mechanical Engineering Department)

JSPM'S Rajarshi Shahu College of Engineering Tathawade Pune-33

\*\*\*

**Abstract –** In many countries throughout the world struggling with massive amounts of water hyacinths affects in the country's fresh water resources and created problems associated with navigation, national security, irrigation and drainage, water supply, hydro-electricity and fishing. There are several methods available for removing hyacinth from the water source like chemical deposition, Mechanical removal by using various mechanisms, Manual extraction by conventional equipment's etc. Among all of them most effective method for aquatic plant removal is chemical deposition, Due to some important causes it is difficult to implement Chemical deposition practically because of this causes mentioned as, there will be chances of contamination of water, also various solutions may form impurities in water, using of dilute chemicals are harmful to aquatic lifecycle. So, for overcoming that issue, we are designing Mechanical removal of hyacinth or aquatic plant by using conveyor belt and mechanical cutters. In this project we are designed and manufactured water hyacinth remover prototype in which we designed shaft, conveyor, bearing, cutters, design & analysis of main frame and secondary conveyor frame, Design of pulley and selection of motor on the basis of design calculations.

A case study is used to validate this design methodology. Initially, the Main frame and secondary conveyor frame were designed and analysed by using ANSYS R18 and CATIA software for safe design. The results indicate a need for reliable objective evaluation methods. As a consequence of the study, suggestions for improving and applying existing methods are proposed.

**Keywords —** Water hyacinth, mechanical removal, Aquatic plant, Water resources.

### 1. INTRODUCTION

The water hyacinth (*Eichhornia crassipes*) is a floating plant. Recognized as one of the top 10 worst weeds in the world, it is characterized by rapid growth rates, extensive dispersal capabilities, large and rapid reproductive output and broad environmental tolerance. This invasive nuisance often jams rivers and lakes with uncounted thousands of tons of floating plant matter. A healthy acre of water hyacinths can weigh up to 200 tons! "*Eichhornia crassipes* grows in all types of freshwater.

Water hyacinth is a floating water weed with a fibrous root system and dark green rounded leaves up 3 to 5 cm in diameter. The leaf stalks are swollen into spongy, bulbous

structures. Water hyacinths the most predominant, persistent and troublesome aquatic within the world and has posed ecological and economic problems in several countries. Many studies have been conducted to evaluate utilization of water hyacinth and removal of water hyacinth vegetation. The major problems of water hyacinth its affect the countries fresh water resources. Water hyacinth is considered a serious and one of the most noxious aquatic pests in many parts of the world. Its rapid growth has clogged major waterways and created problems associated with navigation, national security, irrigation and drainage, water supply, hydroelectricity and fishing in many countries Because Of its devastating effects on aquatic ecology and 'man, It's called "green devil" or "Bengal tenor" in India, "Florida devil" in America

### 1.1 PROBLEM STATEMENT

This proposed research work aims towards the removing of hyacinth from the river or any other water resources. Some general problem found in surveys are stated below:

#### i) Destruction of biodiversity

Today, biological alien invasions are a major driver of biodiversity loss worldwide. Water hyacinth is challenging the ecological stability of freshwater water bodies, out-competing all other species growing in the vicinity, posing a threat to aquatic biodiversity.

#### ii) Oxygen depletion and reduced water quality

Large water hyacinth mats prevent the transfer of oxygen from the air to the water surface, or decrease oxygen production by other plants and algae. When the plant dies and sinks to the bottom the decomposing biomass depletes oxygen content in the water body. Dissolved oxygen levels can reach dangerously low concentrations for fish that are sensitive to such changes. Death and decay of water hyacinth vegetation in large masses deteriorates water quality and the quantity of potable water, and increases treatment costs for drinking water.

#### iii) Breeding ground for pests and vectors

Floating mats of water hyacinth support organisms that are detrimental to human health. The ability of its mass of fibrous, free-floating roots and semi-submerged leaves and

stems to decrease water currents increases breeding habitat for the malaria causing anopheles mosquito as evidenced in Lake.

**iv) Blockage of waterways hampering agriculture, fisheries, recreation and hydropower** Water hyacinth often clogs waterways due to its rapid reproduction and propagation rate. The dense mats disrupt socioeconomic and subsistence activities (ship and boat navigation, restricted access to water for recreation, fisheries, and tourism).

**v) Physical Problems** – “Water hyacinth mats clog waterways, making boating, fishing and almost all other water activities impossible. Water flow through water hyacinth mats is greatly diminished, an acre of water hyacinth can weigh more than 200 tons; infestations can be many acres in size.”

**vi) Ecological Impacts** – “Water hyacinth mats degrade water quality by blocking photosynthesis, which greatly reduces oxygen levels in the water. This creates a cascading effect by reducing other underwater life such as fish and other plants. Water hyacinth also reduces biological diversity, impacts native submersed plants, alters immersed plant communities by pushing away and crushing them, and also alter animal communities by blocking access to the water and/or eliminating plants the animals depend on for shelter and nesting.”

**Vii) Economic Impacts** – “In Florida, millions of dollars a year used to spend on water hyacinth control; finally getting the plant under "maintenance control" has greatly reduced that expenditure.”

Therefore, while searching for a related problem with common philosophy, it is very important to extract or remove this floating mats of water hyacinth. The mechanical hyacinth remover using Cutter and conveyor belt is one of the best option for removing this mat.



**Fig 1.1 Mats of Hyacinth in river or water ponds.**

## 1.2 OBJECTIVES

After an extensive study of the subject under focus and collecting information from the related researchers, peers and users, the current research project envisages the following as its primary objectives.

- To identify and address current environmental problems of poor and developing nations
- To Minimize contamination of water in ponds, rivers, lakes etc. by using the mechanical removal, as per their functionality and usability concerns.
- To develop a methodological model during concept design phase to transform designed values for implementing the prototype of mechanical harvester.
- To investigate the current evaluation process and to find the problem behind its implication
- To automate the concept design phase with a case study considering hyacinth remover
- To reduce toxicity of water by removing hyacinth plant to safeguard the aquatic life.
- To improve aqueous environment by using mechanical fastenings and material handling equipment.

## 2. CONSTRUCTION AND WORKING:

### 2.1 CONSTRUCTION:

#### a. Motors :

There are two motors used in whole assembly of Hyacinth remover.

#### i) Motor-1

The motor is single phase 12 volt DC motors, which indicates that the speed is infinitely variable from 0-200 rpm.

#### ii) Motor-2

The motor is single phase 12 volt DC motors, meaning that the speed is infinitely variable from 0-100 rpm. The motor is mounted on the machine frame and is connected to rotary cutter shaft and also linear blades through connecting links.

#### b. Rotating Shaft and Cutter:

Rotary blades are made up of mild steel material (M.S.). We used 6 linear blades, which is fixed on Shaft which is also made up of mild steel of 15 mm diameter. Shaft is rotated with the help of v- belt and pulley arrangement through second motor of 100 rpm. Blades are manufactured in S-shape with guiding horizontal blades attached on the assembly.

**c. Conveyor belt**

Conveyor belt is made up of P.U material with fibre meshing of plies provided to avoid slippage. Conveyor Belt is cut into 250 mm width and 1300 (approx.) length. Conveyor belt has 3 no plies and belt is fasten with stitches by leather needle. This is moving on driven and driver pulleys by motors. Conveyor belts transport the threshed leaves or cut leaves into a box container.

**d. Drive and Driven Rollers**

There are mainly two rollers are used one is solid roller which is driver where shaft is housed in UCFL bearings and other is driven roller which is hollow and shaft fixed with the secondary frame having slot for tensioning or tightening the belt. Drive and driven rollers made up of Mild steel with vulcanised rubber coating on it. Drive and driven rollers are quiet heavier in weight of approximately 3.5-4.0 kg. As it is made up of MS it has high strength and high rotating capacity. Conveyor belt is rotated by means of drive and driven rollers by motor 1 which is fixed on the base frame of the boat or any floating container. Drive roller is fixed on top of the secondary frame while driven roller is fixed with secondary frame on lower side. Secondary frame is fixed with an inclined angle of 30 degree with main frame. It is a Heart of the whole mechanism.

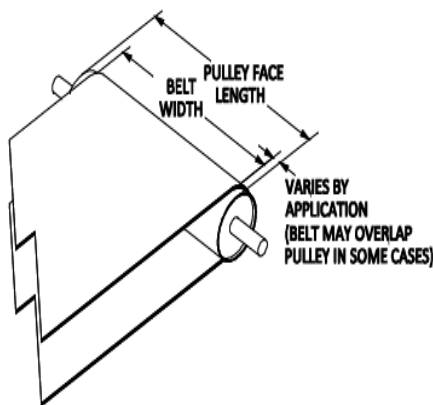

**Fig. Belt and Roller Arrangement.**

**e. Main Frame :**

Main frame is made up Aluminium alloy of 25 mm × 25mm hollow box Section bar of rigid structure. Main frame is constructed in rectangular structure and used as support Structure. Secondary frame is mounted on the main frame by using L-clamps. Main frame is fabricated with the help of argon aluminium welding. This assembly plays an important role of body of Mechanism. Fig shows the design model of main frame. The entire assembly is mounted on main frame which is Rotary cutter with blades, Secondary frame bearings, conveyor, and motors etc.

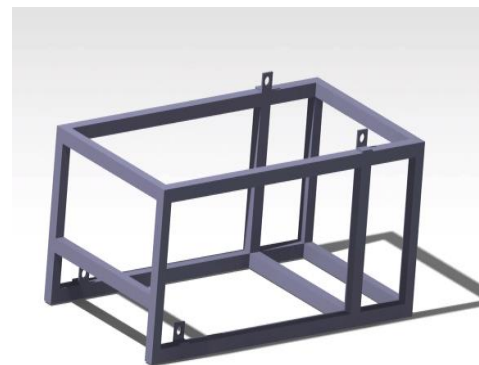

**Fig. Main Frame.**

**f. Secondary Frame:**

Secondary frame is also made up Aluminum alloy of 25 mm × 25mm hollow box Section bar. Two box section tubes are welded by a L-Section of 25 mm × 25mm As shown in below fig. A structure is used for support member of rollers. Secondary frame is mounted on the main frame by using L-clamps. It is fixed inclined with the main frame of 30 degree angle.

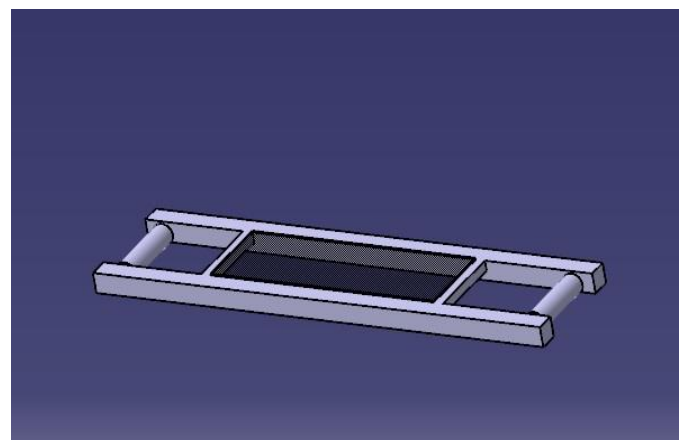

**Fig. Secondary Frame**

**g. Bearing**

We select ball bearing on which radial load is act. There are two different types of bearings and their housing are used for two different rollers. UCFL 202 of inner diameter of 15 mm. is selected on the basis of design type of with two bolt block is used for solid roller which is connected to the motor. Also Simple ball bearing is used for the driven hollow roller in which it is fixed inside the roller with inner diameter of 15 mm for fixed shaft. The shaft of drive and driven rollers are held in ball bearing mounted in bearing housing and rotates freely in it. Both the bearings are selected as per the ASME design data book and the bearing catalogue provided by the manufacturer.

**3.2 WORKING:**

A mechanical water hyacinth remover or harvester a type of small vegetation cutting machine used for a variety of tasks, including aquatic plant cutting, and this small pieces collecting and trash removal in rivers, lakes, bays, and harbours. Harvesters are designed to cut, collect and unload vegetation and debris using a cutters, guide, and conveyor system on ship, we built a small prototype so it has adjustable to the small appropriate cutting height, up to 0.5 feet below the surface of the water. Cutter bars cut, and collect material and bring it aboard the vessel using the conveyor; when the conveyor has reached capacity, cut material is transported to a disposal site (ship) although the conveyor continuously operate so no matter quantity of the vegetation it can transfer also small amount of vegetation and offloaded using the conveyor. Cutter are typically driven by a 12 volt Direct current motor which has 100 rpm, motor provide powers to a cutter bars with the help of pulley arrangement and the conveyor system is driven by 200 rpm motor having capacity or torque of 35 kg-cm. Drive roller is powered by this 200 rpm motor having very high torque. Power is transmitted by means of belt and pulley arrangement. Pulley having diameter of 50mm. Drive roller are mounted on top side of the secondary frame with UCFL 204 two bolted bearings as shown in fig. Also Driven roller is mounted on secondary frame which is fixed on main frame with an angle of 30 degree to the base of main frame. Driven roller is hollow cylindrical pipe with rubber coating on it is generally driven by the drive roller. Belt of P.U. material is arranged or moving on the rollers. Belt is tighten by the driven roller which is linearly move in secondary frame. It is important that belt will be in proper tension, otherwise only roller rotates and belt will be idle.

When the cutter rotates and cuts the hyacinth grass. The harvested grass is then transported to the belt. The belt is rotated continuously with the help of drive and driven roller assembly. Due to this continuous rotation of rollers harvested grass is also continuously transferred from lower end to the upper end of the system. This harvested hyacinth grass is then collected in container and this cycle continues till complete removal of material.

**4. MECHANICAL DESIGN:**

**4.1. DESIGN OF ROLLER SHAFT:**

**4. 1.1 ASME Code for Design of Shaft**

Since the loads on most shafts in connected machinery are not constant, it is necessary to make proper allowance for the harmful effects of loads fluctuations. According to ASME code permissible values of shear stress may be calculated from various relations.

**F<sub>s max</sub>** = 0.18 Sut

= 0.18 x 40

= 7.2 N/mm<sup>2</sup>

Or

**F<sub>s max</sub>** = 0.30 Syt

= 0.30 x 25

= 7.5 N/mm<sup>2</sup>

Considering the minimum of the minimum of the above values,

**F<sub>s max</sub>** = 7.2 N/mm<sup>2</sup>

This is the allowable values of shear stress that can be inducted in the shaft material for safe operation.

**TORQUE (T)** = 35kg-cm/ 10.19716

= 2.9166N-m

**POWER (P)** =  $\frac{2 \times \pi \times N \times T}{60}$

=  $\frac{2 \times \pi \times 200 \times 2.9166}{60}$

**POWER (P)** = 61.08 W

**Diameter of Shaft**

**T** =  $\frac{\pi}{16} \times f_s \times d^3$

2.9166 x 10<sup>3</sup> =  $\frac{\pi}{16} \times 7.5 \times d^3$

**d** = 12.53 mm

**Now considering shaft diameter to 15 mm as standard For torsional failure of shaft,**

**a) Diameter of shaft (d)** = 15 mm

**T** =  $\frac{\pi}{16} \times f_s \times d^3$

f<sub>s</sub> = 16 x 2.9166 x 10<sup>3</sup> / π x 15

f<sub>s</sub> = 4.40 N/mm<sup>2</sup>

(Since, f<sub>s max</sub> = 7.5 N/mm<sup>2</sup>)

AS, f<sub>sact</sub> < f<sub>sallowable</sub>

Therefore, Shaft is safe under torsional load.

**4.2. Design of conveyor:**

**4.2.1 Mass capacity of conveyor (M):-**

Maximum suitable belt inclination ( $\alpha$ ),

$$\alpha = \tan^{-1}(h/lh)$$

$$= \tan^{-1}(310/550)$$

$$\alpha = 30^\circ$$

From table, select 'K' value

$$K = 2.20 \times 10^{-4}$$

Mass capacity of conveyor (M),

$$M = \rho Q$$

$$= \rho k (0.9B - 0.05)^2 \times V, \text{ kg/sec}$$

Where,

$\rho$  = density of water hyacinth  $\text{kg/m}^3 = 670 \text{ kg/m}^3$

$k$  = flowability factor =  $2.20 \times 10^{-4}$

$B$  = belt width = 250 mm = 0.25 m

$V$  = velocity of belt m/sec

**4.2.2 Velocity of belt (V),**

Diameter of Pulley (D) =  $k_1 \times k_2 \times Z_p$

$$= 1.25 \times 40 \times 2$$

$$= 100 \text{ mm}$$

Where,  $k_1$  = Material Factor for plies = 1.25

$K_2$  = Belt tension and arc of contact factor = 40

$Z_p$  = Number of plies. = 2

$$V = \frac{\pi DN}{60}$$

$$= (\pi \times 0.1 \times 200) / 60$$

$$= 1.0471 \text{ m/s}$$

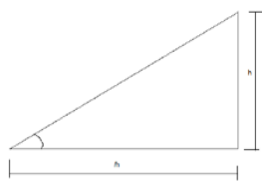

$$M = \rho k (0.9B - 0.05)^2 \times V$$

$$= 670 \times (2.20 \times 10^{-4}) \times (0.9 \times 0.25 - 0.05)^2 \times 1.0471$$

$$= 4.7267 \times 10^{-3} \text{ kg/S}$$

$$M = 17.0162 \text{ kg/hr}$$

$$M_m = \frac{M}{V}$$

$$= (4.7267 \times 10^{-3}) / 1.0471$$

$$M_m = 4.514 \times 10^{-3} \text{ kg/m}$$

**3.2.3 To calculate power requirement on drive pulley (P<sub>0</sub>),**

$$F_1 = F_{\text{slack}}$$

$$F_2 = F_1 + F_{p1}$$

$$= F_1 + \epsilon_{p1} \times F_{\text{slack}}$$

$$= F_{\text{slack}} (1 + \epsilon_{p1})$$

$$= F_{\text{slack}} (1 + 0.06)$$

$$F_3 = F_2 + F_1$$

$$= F_2 + M$$

$$= F_{\text{slack}} (1 + 0.06) + (3.544 \times 10^{-3})$$

$$F_4 = F_3 + F_u$$

$$= F_{\text{slack}} (1 + 0.06) + M_m \times 9.81 \times h$$

$$= F_{\text{slack}} (1 + 0.06) + 18.3077$$

$$F_{\text{tight}} = F_4 + F_{p2}$$

$$= F_4 + \epsilon_{p2} \times F_4$$

$$= F_4 (1 + \epsilon_{p2})$$

$$F_{\text{tight}} = F_{\text{slack}} \times 1.1236 + 19.406$$

Assume,

$$\mu = 0.25$$

$$\theta = (180 \times \pi) / 180$$

$$= 3.1415 \text{ rad}$$

As we know,

$$\frac{F_{\text{tight}}}{F_{\text{slack}}} = e^{\mu \theta}$$

$$= e^{(0.25 \times 3.1415)}$$

$$F_{tight} = 2.1932 \times F_{slack}$$

$$2.1932 \times F_{slack} = F_{slack} \times 1.1236 + 19.406$$

$$F_{slack} = 17.124 \text{ N}$$

$$F_{tight} = 37.558 \text{ N}$$

**Power required on drive pulley (P<sub>0</sub>),**

$$P_0 = (F_{tight} - F_{slack}) \times V, W$$

$$= (37.558 - 17.124) \times 1.0471$$

$$P_0 = 27.397 \text{ W}$$

Power rating of standard electric motor selected is,

$$P_i = 61.08 \text{ W.}$$

Factor of Safety for conveyor belt

$$1) F_{tmax} = F_{tight} + M_b \times V^2$$

$$= 37.558 + 1.041^2$$

$$F_{tmax} = 38.654 \text{ N}$$

$$2) F_{bs} = S_{ut} \times B \times Z_p$$

$$= 200 \times 0.25 \times 2$$

$$F_{bs} = 100 \text{ N}$$

$$FOS = F_{bs} / F_{tmax}$$

$$= 100 / 38.655$$

$$FOS = 2.58$$

**5. Analysis of Frame :**

For the required parameters and design construction the analysis is done on ANSYS software. Following figure shows the Stress values and the safe design.

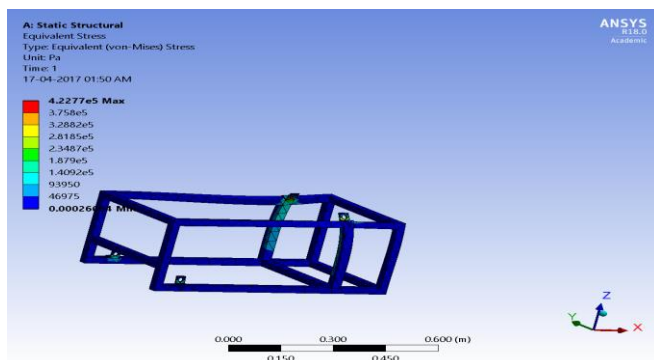

**Fig. Stress values for main frame.**

**6. CONCLUSION**

In this paper we concluded the mechanical water hyacinth remover or harvester is most effective, efficient, economical compare to other method. One person can easy to operate from start to finish entire operation on machine. It is versatile to pulls, cut, and skims weeds in shallow water. It can be used as multipurpose to gathers floating debris and algae. It improves the operational stability. It has 95% effective weed pulling. Due to mechanical control effective contaminated water resources management are done. Therefore now it's the perfect time to making such machine and save our, lake, cannels, rivers.

**7.ACKNOWLEDGMENT**

We would like to express our sincere gratitude to the Hon. Principal Prof.Dr.R. K. Jain sir, Head of Department Prof Dr. A. M. Badadhe sir, and all the professors and lab incharge .They all give us moral support and proper guidance to do this project. Also we are very thankful to our Project Guide Prof. D P. Borse sir for the valuable support and guidance during this work .

**8. Refrences:**

1. Brenzy O, Mehta I, Sharma RK, Studies on evapotranspiration of some aquatic weeds. Weed Science, 1973.
2. Abbasi SA. Renewable energy from aquatic biomass. In: processing of the International Congress on Renewable Energy Source. CSIE, Madrid. 1987, 60-69.
3. Devendra Kumar, R.K. Mandloi "Analysis & Prospects of Modification in Belt Conveyors - A Review" IJERA Vol. 3, Issue 1, January -February 2013, pp.581-587.
4. VINOD M. BANSODE, ABHAY A. UTPAT "Fatigue Life Prediction of A Butt Weld Joint In A Drum Pulley Assembly Using Non-Linear Static Structural Analysis" Dept. of Mechanical Engineering, College of Engineering, Pandharpur, India.
5. Kathalyn S. Tung "The Effectiveness of Mechanical Control of Water Hyacinth (Eichhornia crassipes)"
6. Ratchanon Keawmanee 'Water Hyacinth - The Green Potential.' (5-15-2015)
7. Narasinmha Ramula K and Benargee G, they provided new baseline information on the diversity, distribution and interspecific associations of floating-leafed and submersed aquatic plants in Nagaram tank, International Journal of Fisheries and Aquatic studies 2016.

## 9.BIOGRAPHIES



Mr. Prasad V. Shastri  
(Mechanical Engineering)  
JSPM's RSCOE Tathawade, Pune



Mr. Abhishek V. Bende.  
(Mechanical Engineering)  
JSPM's RSCOE Tathawade, Pune



Mr. Devendra V. Chopade  
(Mechanical Engineering)  
JSPM's RSCOE Tathawade, Pune



Mr. Sagar T. Ubhe.  
(Mechanical Engineering)  
JSPM's RSCOE Tathawade, Pune



Prof. Mr. Dilip P. Borse,  
Assistant Professor  
(Mechanical Engineering)  
JSPM's RSCOE Tathawade, Pune.