

# Raspberry Pi Based Smart Toll Collection System

Prof. Chhaya Athavale<sup>1</sup>, Suraj Shinde<sup>2</sup>, Akshay Rajemane<sup>3</sup>, Nishant Mohite<sup>4</sup>

<sup>1</sup>Asst. Professor, Dept. of Electronics and Telecommunication, Sinhgad Academy of Engineering, Pune, India

<sup>2,3,4</sup>Student, Dept. of Electronics and Telecommunication, Sinhgad Academy of Engineering, Pune, India

\*\*\*

**Abstract** - This paper proposes the Raspberry based toll collection system for toll tax collection. Existing toll collection systems in India make use of manual cash transactions. Exponential growth in traffic is observed in past years. Manual toll collection systems are major bottlenecks of high speed commutation. This results in problems like longer queues, wastage of time and increased fuel consumption at toll booths. This project implements an electronic toll collection system using Raspberry Pi and passive RFID tags. These electronic booths automatically collect toll from user account corresponding to the RFID tag pasted on windshield of car. The toll is deducted from the user account each time it passes through a toll plaza. An RFID reader with high power and high directional property is placed overhead for detecting the passive tags pasted on windshield. On-site LCD screen displays details about the toll deducted and remaining account balance. On successful transaction barricade is opened. Recharge facility for accounts having insufficient balance is provided on toll booths. This system addresses all issues like time wastage, fuel consumption and collection errors at one go. Electronic system will also bring transparency in toll tax collection and stop corruption and tax evasion issues.

**Key Words:** Raspberry Pi, RFID tag, Electronic Toll Collection, VB Application, Client-Server Architecture

## 1. INTRODUCTION

Toll tax collection systems in India are based on manual cash transactions. The operator at the toll booth manually collects toll amount according to vehicle type, in form cash bills. He hands the receipt for same. This modus operandi is time consuming. Due to such systems bottleneck is created in the high speed highways. There are chances of error, time wastage, and longer queues leading to fuel wastage.

Suppose time taken by each vehicle on toll booth is 60 seconds a day (approx.) then time taken in a complete year is  $365 \times 60 = 21900$  sec = 6 hrs. Suppose 10000 vehicles pass through a particular toll booth in a single year, total of 60000 fuel hours are wasted. This is a substantial loss of natural resources.

Transparency in toll collection systems is a major issue these days. Contract for toll collection is in-force until the road contractor reimburses the cost incurred for construction, maintenance and facilitation of the roads. But due to manual systems there is no definite way to determine total amount collected till date. This leads to the misuse of the toll

collection rights. It is difficult for government to determine the termination of contract, paving the way for corruption.

The Raspberry Pi based toll collection system works on the client-server architecture. There is a centralised server which stores database of users. A client Raspberry Pi at every toll booth is connected to the server via internet. Raspberry Pi controls hardware i.e. displays, RFID reader, motor and simultaneously it communicates with the server with the queries regarding user account. Due to this dual role of Raspberry Pi, separate need of microcontroller is eliminated. This results in a cost effective implementation of the system.

## 2. LITERATURE SURVEY

Electronic toll collection was first implemented in 1986. After that many electronic toll collection systems are implemented with different techniques. Some of them are as follows:

System proposed in [1] uses Wi-Fi for communication with the Smartphone of user. This phone contains all necessary data related to the user registration. User is registered at toll booth automatically as he passes through. But in countries with less Smartphone penetration, system may not work effectively.

System proposed in [2] uses overhead camera to detect number plate and uses it as the account number of the user. Database is stored in central server. But deterioration of number plates or duplicate numbers may introduce false positives in the system.

System proposed in [3] uses NFC chips for detection of vehicle identity. The NFC chips are designed to work in the close vicinity of reader. If the distance between reader and chip is more than critical limit, system will not detect the vehicle.

Considering the limitations of former systems, RFIDs stands out with many advantages. RFID tags needs no battery as they can work perfectly with the power transmitted by RFID reader. Unlike number plate physical wear and tear has no harm. Distance of tag from reader is no issue as high power radio waves can detect the tag up to sufficient distance. Unlike Wi-Fi it does not require any authentication hence faster than system proposed in [1].

More to this the raspberry pi based toll collection system provides a cost effective implementation as components are fairly inexpensive.

### 3. SYSTEM DESIGN AND IMPLEMENTATION

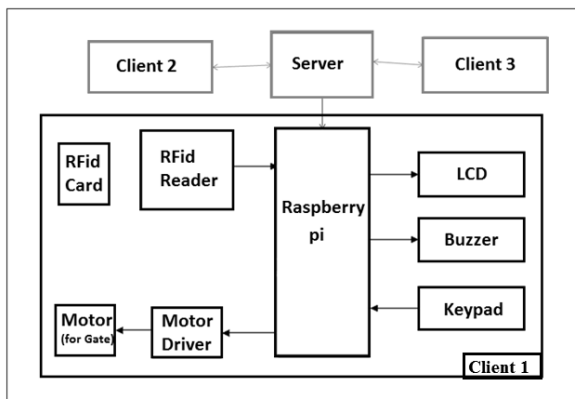

Fig -1: System Block Diagram

This system is implemented with following major components:

- Raspberry pi model 3 B
- RFID Reader
- DC Motor Driver L293D
- 16x2 Character LCD Display

#### 3.1 Raspberry Pi Model 3 B

The Raspberry Pi 3 is the third generation Raspberry Pi single board computer. It is based on a 1.2GHz 64-bit quad-core ARMv8 CPU. It has Inbuilt 802.11n Wireless LAN and Bluetooth 4.1. Bluetooth Low Energy (BLE) makes it efficient to use with battery operated devices. It has 1 GB RAM. 4 USB ports makes it efficient to connect external hardware. 40 GPIO pins with TTL output. They have current source or sinking ability up to 16mA. Ethernet port makes it easy to connect with network. VideoCore 4 3D graphics core support Full HDMI output along with Combined 3.5mm audio jack and composite video. This makes it back compatible with older TV systems. Camera interface (CSI) and Display interface (DSI) ports are provided for direct interfacing of camera and display. Micro SD card works as secondary storage of the computer.

Comparatively low capacity hardware is used in Raspberry Pi. Hence a lighter version of desktop Linux is used. It has only essential libraries and software to support functioning of the Raspberry Pi. This system makes use of latest Raspbian Jessie OS.

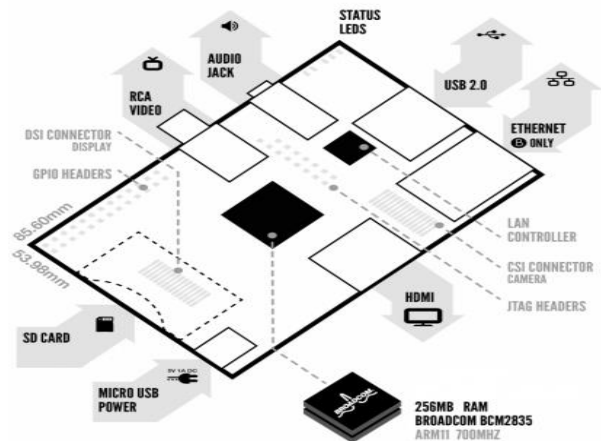

Fig -2: Raspberry Pi Hardware Architecture

#### 3.2 RFID Reader

A Radio Frequency Identification system consists of an antenna or coil, a transceiver and a transponder electronically programmed with unique information. RFID tag consists of a microchip connected to an antenna, which is constructed of a small coil of wires. Data is stored in the IC and transmitted through the antenna to a reader. Most RFID tags contain at least two parts. One is an integrated circuit for storing and processing information, modulating and demodulating a (RF) signal, and other specialized functions.



Fig -3: RFID Transmitter and Receiver

The second is an antenna for receiving and transmitting the signal. A reader is basically a radio frequency (RF) transmitter and receiver, controlled by a microprocessor. It works on a 5V supply. Typical power consumption is less than 50mA. The reader, using an attached antenna, captures data from tags, then passes the data to Raspberry Pi.

The number contained in RFID tag is of 11 digits in HEX format. This number is sent via either serial interrupt or Wiegand protocol.

### 3.3 L293D Motor Driver

L293D motor driver can drive two DC motors simultaneously. L293D IC is a dual H-bridge driver IC. Single H-bridge is able to drive a dc motor in both directions. L293D IC is a current amplifier IC as the output from the sensor is not sufficient to drive motors itself so L293D is used for this purpose. L293D has 16 pins, having two enables pins. This pins should always be high to enable both the H-bridges.

#### Features

- L293 and L293D variants
- Wide Supply-Voltage Range: 4.5 V to 36 V
- Separate Input-Logic Supply
- Internal ESD Protection
- Thermal Shutdown
- High-Noise-Immunity Inputs

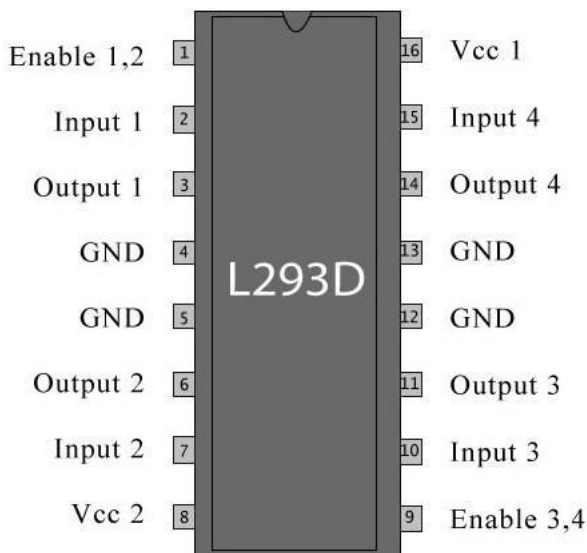

Fig -4: L293D pin Diagram

Chart-1: L293D Logic Table

Input 1	Input 2	Motor Direction
1	0	Clock-wise
0	1	Anti clockwise
0	0	Idle
1	1	Idle

### 3.3 16x2 LCD Display

The display contains two internal single byte registers, one for commands (when RS=0) and the other for characters to be displayed on the display (when RS=1). It consists of a user-programmable RAM area (the CGRAM) that can be programmed to display desired character, formed by using a 5x7 dot matrix. To select between these two data areas, the

hex command byte 0x80 will be used to signify that the display RAM address 00h is chosen. Data bus is 8 bit wide.

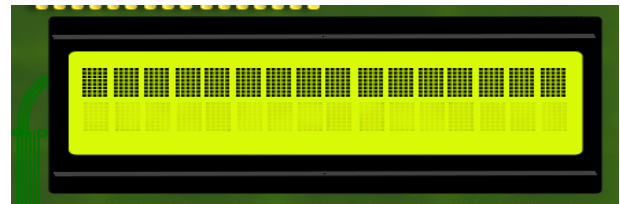

Fig -5: 16x2 character LCD display

Liquid Crystal Display also called as LCD is very helpful in debugging purpose. The LCD controller is HITACHI 44780 which provides a simple interface between the controller 1 & dot matrix. These LCD's are very simple to interface with the raspberry Pi. They are cost effective.

### 4. SYSTEM WORKING

When the vehicle passes through the toll plaza the RFID tag is detected by the RFID receiver placed overhead. This reader is constantly emitting RF waves at 125KHz. As soon as the tag comes in field of receiver the tag number is detected and sent to Raspberry Pi via serial interface. The LCD will display card detection message and number of card.

If sufficient balance is present in corresponding user account then stipulated amount will be deducted. This amount depends upon type of vehicle. The motor driver will open the gate for 30 seconds and the vehicle will pass through the toll booth. In case of insufficient balance in user account the user will have to pay toll manually with some penalty. The user can recharge his account from the toll booth itself. Penalty will encourage the user to keep sufficient balance in account. New user can also be registered at the toll booth.

### 5. RESULTS

Server is running on a windows application created with the Visual Basic 6. All necessary functions are implemented in this application. It gives comprehensive control of the system from server.

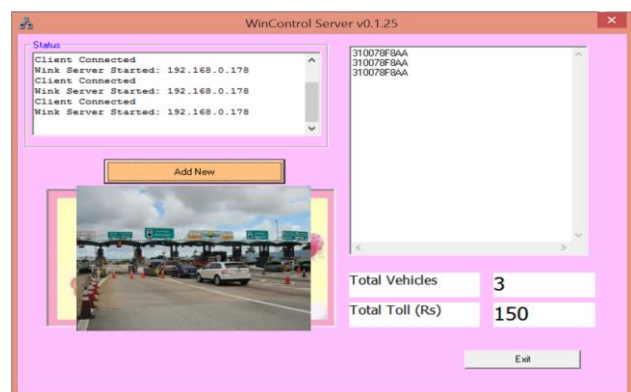

Fig -6: Server application-main screen

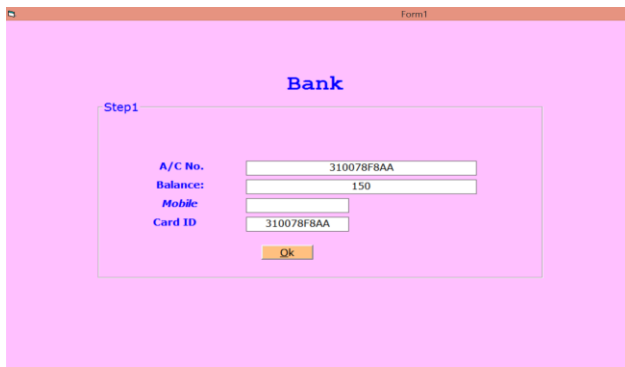

Fig -7: Server application-user management screen

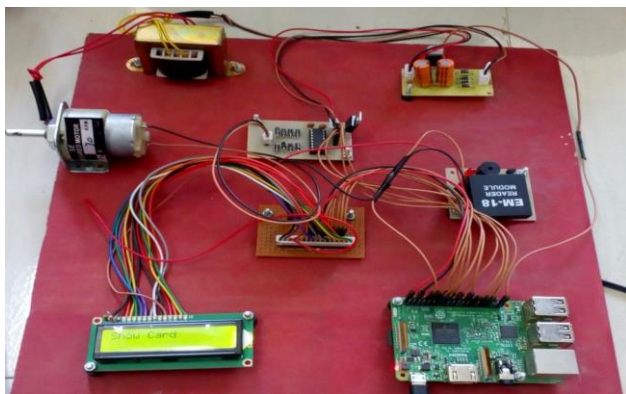

Fig -8: Hardware Interfacing

## 6. ADVANTAGES

- RFID system is better than systems mentioned in [1][2][3]. RFID tag is much faster than any other system.
- No fuel wastage.
- No traffic jams at toll booths.
- Transparency in toll collection.
- Low infrastructure costs.

## 7. CONCLUSION

Issues like long queues are completely eliminated by implementation of the system. This system saves time and fuel. Transparency in toll collection is increased as reports are stored digitally. Need for manpower is reduced on a large scale. User will get proper information of his account on the toll booth display. Skipping of toll will be avoided. Therefore, the Raspberry Pi based Automatic Toll Collection System using GSM will eliminate many issues of the toll plaza at one go. This system will ensure faster commutation on highways.

## 8. FUTURE SCOPE

Currently system uses prepaid mode. This can be changed to postpaid. For the prepaid system online recharge system can be implemented. Cameras can be used for more stable system in case of RFID failure. System for stolen vehicle detection can be implemented with little change in software.

## ACKNOWLEDGEMENT

We thank our teachers for their support and encouragement for this work. We would especially thank Prof. Chhaya Athavale for her guidance and support throughout the process and always being there for help.

## REFERENCES

- [1] Shital Ladkat "M-toll using Wi-Fi technology" IRJET Volume: 03 Issue: 04 | April-2016
- [2] Veera venkatesh "Smart Traffic Control System for Emergency Vehicle Clearance" IJIRCCE Vol. 3, Issue 8, August 2015
- [3] S B Shinde "Toll automation system using NFC" JETIR January 2016, Volume 3, Issue 1
- [4] R H Chaudhary "A model for the benefits of electronic toll collection System" Theses and dissertation