

## Design and analysis of RJ45 Plug

Prathamesh Samant<sup>1</sup>, Ravindra Sawant<sup>2</sup>, Suraj Gole<sup>3</sup>, Shreekanth Pawar<sup>4</sup>

<sup>1,2,3,4</sup> Students, Dept. of Mechanical Engineering, JSPM NTC Pune, Maharashtra, India

\*\*\*

**Abstract** – This research work was carried out to investigate the tactile feedback of snap-fit fasteners when used in manual assembly. An important aspect of this assembly process is the assembler's ability to perceive the snap-fit's engagement. This sensing of engagement yields a high level of confidence that assembly is both complete and secure. In this work, designed and analyses standard RJ45 Plug & according to result we modified the design of RJ45 Plug to improve it's life cycle.

**Key words:** Snap-fit, RJ45 Plug, Polariscope, Polybutylene Terephthalate, diffused light.

### 1. INTRODUCTION

Snap-together connectors have been used for thousands of years. The first snap-fit was made up of metal. Some of the oldest snap-fits found are snap fasteners or buttons, developed for the Chinese army. Metal snap fasteners, spring clips, and other snap-type connectors are still in broad use today. With the development of new flexible yet springy materials, such as molded plastic, and new manufacturing processes, many new variations in these types of connectors have been invented, and are commonly called snap-fits. They can be found in on our phones, laptops, keys and other household devices. Engineers have studied and developed these snap-fits, creating formulae concerning the amount of deflection allowed on the components, amount of torque one can take, and the amount of space one can allow in order to be detached.

Like the press fit, the snap fits is a simple assembly method that joins two parts without using any additional components or fasteners. An economical and quick method of joining plastic parts is by a snap-fit joint. A snap-fit joint can be designed in such a way that it can be easily separable or inseparable without breaking one of its components. The strength of the snap-fit joint depends on the material used, its geometry and the forces acting on the joint. A snap fit, also referred as a lock arm, consists of a hook and a groove. During assembly, the hook can be fully deflect or partially deflect by the mating part. Once inside the groove, the hook returns to its original position. The hook-and-groove interaction gives the snap fit its gripping force.

There are two major categories of snap fits. Permanent or one-time assembly snapfits, mostly used for disposable consumer products, are assembled in the manufacturing process, never to be removed. Multiple snap fits are used in applications, such as pen caps and bottle caps, that may be opened and closed many times, and products like automotive parts that have to be disassembled for servicing. Both categories include several snap fit design families. A cantilever beam is a basic hook-and-groove joint with a beam that fits axially into a slot in the mating part. A *curved beam* is a variation of the cantilever type, which includes a bend in the beam. The annular snap fit is a round or oval joint found in products such as pen and bottle caps. The spherical snap fit features a dome-shaped protrusion that snaps into an indentation in the mating part. A torsional beam snap fit uses the shear stress of a second beam to hold it in position.

Purpose to use snap-fit-

1. Reduces assembly costs.
2. Are typically designed for ease of assembly and are often easily automated.
3. Replaces screws, nuts, and washers.
4. Are molded as an integral component of the plastic part.
5. No welding or adhesives are required.
6. They can be engaged and disengaged.

### 2. PROBLEM STATEMENT

Previous design of snap-fit joint fails due to fatigue i.e. locking and unlocking it many times. Sometimes joints get loosen because repetitive actions. There are always some Ethernet cables around with broken tab. Now RJ45 Plug no longer locks properly which makes the connection unreliable.

### 3. METHODOLOGY

In this work Finite element analysis is used to determine the stress concentration on RJ45 plug. All methodology is discussed in above to achieve the project's objectives. Virtual model created using FEM tool. Further analysis and modification were then executed to the existing Available design of RJ45 plug

design and finally proposed a new design of RJ45 plug. For the purpose of this study RJ45 plug was modeled using ANSYS Workbench - Design Modeler software according to the original size of structure. The model was then imported into Finite element software ANSYS. The purpose was to determine the stress concentration. For the meshing purpose, 20 node-hexahedron elements were chosen to model the RJ45 plug. Hexahedron elements gave a closer dynamic behavior to the experimental results.

The next step was to undertake experimental analysis on polariscope. This was to determine the fringes pattern on the scaled model of RJ45 plug. In order to calculate the stress analysis and hence life cycle of Available as well as modified design of RJ45 plug. Then the result from the finite element analysis and experimental analysis were then compared in order to find the co-relation between both methods.

The purpose of carrying out the co-relation analysis was to determine how far the finite element analysis agrees with model testing. Based on overall result, life cycles of Available and modified designs are compared.

1. Selection of application (RJ45 plug is selected and material PBT).
2. RJ45 plug to be design in CATIA V5R19 (Available model in the market).
3. Load will be apply on lever of RJ45 plug until it get deflect to maximum limit. Calculation of load by using weighing machine.
4. Analysis of RJ45 plug in ANSYS WORKBENCH for calculated load (Available design in market).
5. Fatigue life cycle calculation of available market design by using design formulae.
6. Modification of market design and analysis of modified design is to be done.
7. Fatigue life cycle calculation of modified design by using design formulae.
8. Result of modified design will be selected.

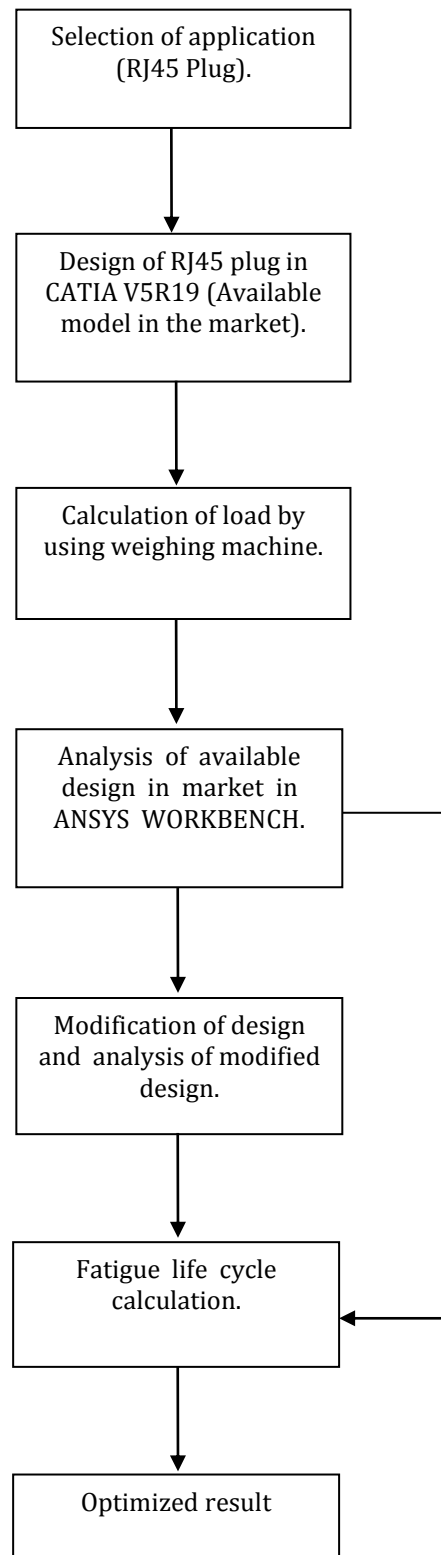

Chart-1: Flowchart of methodology

#### 4. DESIGN CONSIDERATION

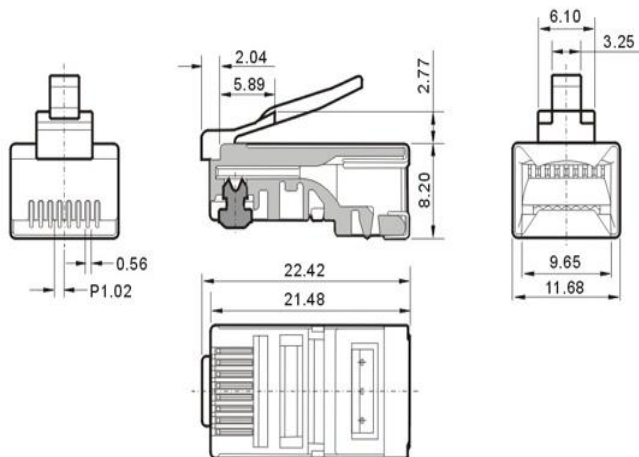

Fig -1: Dimension of RJ45 Plug

Fig -1 is the available design of RJ45 plug in the market. Polybutylene Terephthalate (PBT) is a thermoplastic engineering polymer that is used as an insulator in the electrical and electronics industries. It is a thermoplastic (semi) crystalline polymer, and a type of polyester. PBT is resistant to solvents, shrinks very little during forming, is mechanically strong, heat resistant up to 150°C (or 200°C with glass fibre reinforcement) and can be treated with flame retardants to make it noncombustible. PBT is closely related to other thermoplastic polyesters. Compared to PET (polyethylene Terephthalate), PBT has slightly lower strength and rigidity, slightly better impact resistance, and a slightly lower glass transition temperature. PBT and PET are sensitive to hot water above 60 °C (140 °F). PBT and PET need UV protection if used outdoors, and most grades of these polyesters are flammable, although additives can be used to improve both UV and flammability properties.

In this work the digital weighing machine is used for observing how much load RJ45 Plug required for its working. For that at the beginning RJ45 plug need to be stick on the digital weighing machine by two sided stick tape and we made a fixture which is attached to a string and then calculated the load at which RJ45 Plug deforms to its maximum.

Applied Load on RJ45 plug = 3.822 N

#### 5. DESIGN & ANALYSIS

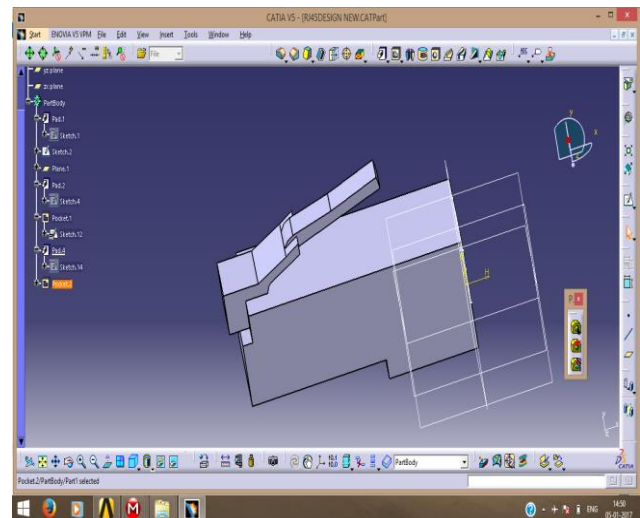

Fig -2: Design of RJ45 Plug (Available)

Fig-2 is the available design of RJ45 Plug in the market which is designed in CATIA V5R19. It has side fillet of 0.651mm.

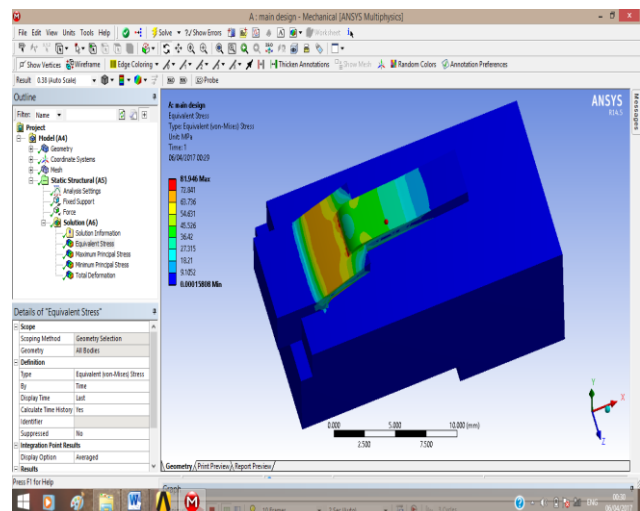
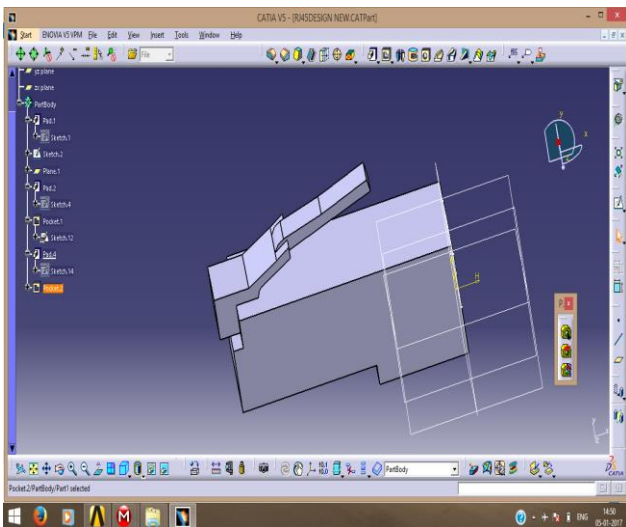

Fig -3: Analysis of RJ45 Plug (Available)

Fig-3 shows the analysis of RJ45 Plug of available design with fillet radius of 0.651 mm. From analysis it is observed that the maximum stress acting on the component is 81.946 N/mm<sup>2</sup> and minimum stress is 0.0001506 N/mm<sup>2</sup>. Life cycle of available design is up to 3173.752 cycles.



**Fig -4:** Design of RJ45 Plug (Modified)

Modified design of RJ45 Plug designed in CATIA V5R19 is shown in Fig-4. Modification of the RJ45 plug is done by changing its dimensions of fillet radius from 0.651 mm to 0.551mm.

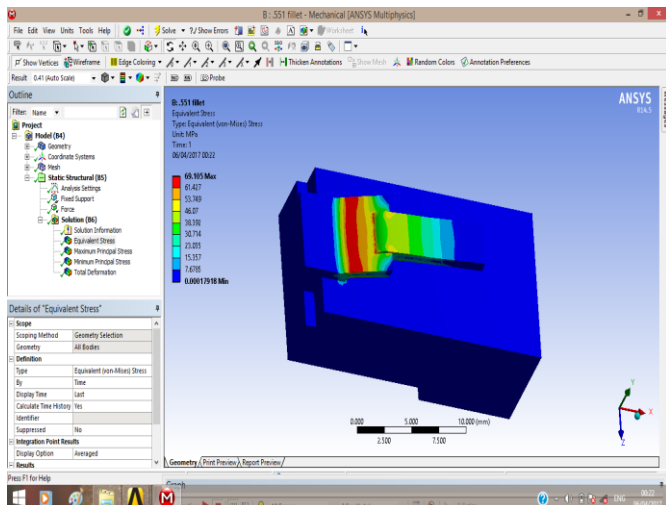

**Fig -5:** Analysis of RJ45 Plug (Modified)

The analysis of RJ45 Plug with 0.551 mm of fillet radius is shown in Fig-5. It is observed that stress concentration of RJ45 Plug changes to 69.105 N/mm<sup>2</sup> and its Life has been increased up to 12726 cycles.

## 6. RESULT & DISCUSSION

In the table 1 & 2 comparison of stress concentration that is maximum stress and minimum stress of RJ45 Plug with original design and modified designs is given.

**Table-1:** Stress values for Available design

Original Design	$\sigma_{max}$	$\sigma_{min}$
(Fillet 0.651 mm)	81.946	0.0001581

**Table-2:** Stress values for Modified design

Modified Design	$\sigma_{max}$	$\sigma_{min}$
(Fillet 0.551 mm)	69.105	0.000105

## 7. LIFE CYCLE CALCULATION & FORMULAE

$S_m$  &  $S_a$  is required for calculation of fatigue strength. Fatigue strength i.e.  $S_n$  is the maximum cycle that the material can perform before failure.  $S_{ut}$  is the maximum stress that material can sustain.  $b$  is slope of line which is required for life cycle calculation.  $N$  is the life cycle of the component.

$$1. S_m = (\sigma_{max} + \sigma_{min}) / 2$$

$$2. S_a = (\sigma_{max} - \sigma_{min}) / 2$$

$$3. (S_a / S_n) + (S_m / S_{ut}) = 1$$

$$4. b' = (1/b)$$

$$5. b = -1/3 \times \log_{10}(S_a / 70)$$

$$6. N' = S_n / 70$$

$$7. N = N'^{b'}$$

$$8. \text{Life Cycle} = N \times 10^6$$

Where,

$\sigma_{max}$  = Maximum Stress

$\sigma_{min}$  = Minimum Stress

$S_m$  = Mean Stress

$S_a$  = Amplitude Stress

$S_n$  = fatigue strength

$S_{ut}$  = Ultimate Tensile Stress

$N$  = Life Cycle

## 7.2 Life cycle comparison

In the table 3 & 4 comparison of life cycle of RJ45 Plug with original design and modified designs is given.

**Table no-3:** Life cycle of available design

Original Design	Life cycle
(Fillet 0.651 mm)	3173.752

**Table no-4:** Life cycle of modified design

Modified Design	Life cycle
(Fillet 0.551 mm)	12726.18

## 8. CONCLUSION

From analysis of modified design of RJ45 plug it is observed that, due to changes in cross section maximum stress acting on the RJ45 plug minimizes which causes to life cycle improvement.

The life cycle of the available design is 3173.752 cycles is improved by the modified design up to 12726.18 cycles. It can be conclude that the life cycle of the modified design of the RJ45 plug increased by 4 times.

From observation it comes to know that if RJ45 plug is designed with the fillet radius of 0.551 mm then its reliability increases by 4 times compare to available design in the market.

## ACKNOWLEDGEMENT

We take this opportunity to thank our head of the department of mechanical engineering and my project guide Prof. A.S.Saruk for their valuable guidance and providing all necessary facilities, which are indispensable in the completion of this technical presentation.

We are also thankful to staff members of mechanical engineering department.

## REFERENCES

[1] Leonard Rusli, Anthony Luscher, Carolyn Sommerich, "Force and tactile feedback in preloaded cantilever snap-fits under manual assembly"

[2] Fuhong Dai, Hao Li, Shanyi Du. - "A multi-stable lattice structure and its snap-through behavior among multiple states"

[3] John Carrell ,Derrick Tate, Shiren Wang, Hong-Chao Zhang - "Shape memory polymer snap-fits for active disassembly"

[4] Christoph Klahn, Daniel Singer, Mirko Meboldt. - "Design Guidelines for Additive Manufactured Snap-Fit Joints"

[5] Michael Roos, Benjamin Horn, Sebastian Gramlich, Stefan Ulbrich, Herman Klobberdanz. - "Manufacturing Integrated Algorithm-Based Product Design Case Study Of Snap Fit Fastening"

[6] Rohit M. Kshirsagar and D. B. Pawar PG student, Dr.Sau. K. G. I. E. T. Darapur, Amravati and India. - "Design & Analysis of Snap Fit Joint in Plastic Part"

[7] Yi-Ho Chen, Chao-Chieh Lan - "Design of a constant-force snap-fit mechanism for minimal mating uncertainty"

[8] Tye Hyun Baek - "Development and test of multipurpose polariscope".

[9] Naoto Iwata, Osamu Sato, Kohji Ohno, Koichi Sakajiri ,Sungmin Kang , Masatoshi Tokita - "Transparent and high permittivity films of poly(methyl methacrylate) grafted 7 nm barium titanate particles prepared by surface-initiated atom transfer radical polymerization".

[10] J. Tsay, H.-A. Chang, C.-K. Sung, Design and experiments of fully compliant bistable micromechanisms, Mechanism and Machine Theory 40 (1) (2005) 17–31.

[11] B. Willems, W. Dewulf, J.R. Duflou, Active snap-fit development using topology optimization, International Journal of Production Research 45 (18) (2007) 4163–4187.

[12] N. Dechev, L. Ren, W. Liu, L. Cleghorn, J.K. Mills, Development of a 6 degree of freedom robotic micromanipulator for use in 3D MEMS microassembly, IEEE International Conference on Robotics and Automation, Orlando, FL, 2006, pp. 281–288.

[13] P.A. Tres, Designing Plastic Parts for Assembly, Hanser Gardner Publications, Cincinnati, OH, USA, 2006.

[14] P.R. Bonenberger, The First Snap-Fit Handbook: Creating Attachments for Plastics Parts, Hanser Gardner Publications, Cincinnati, OH, USA, 2005.

[15] S. Genc, R.W. Messier Jr., G.A. Gabriele, A systematic approach to integral snap-fit attachment design, Research in Engineering Design 10 (1998) 84–93.

[16] G. Suri, A.F. Luscher, Evaluation metrics for the rating and optimization of snap-fits, Research in Engineering Design 12 (2000) 191–203.