

# A Series Active Filter for Power Quality Compensation

Priyanka Shintre<sup>1</sup>, Dr. D.R.Patil<sup>2</sup>

<sup>1</sup>Student, Electrical Engineering Department A.D.C.E.T Ashta, Sangli (M.S) India

<sup>2</sup>Associate Professor, Department of Electrical Engineering, Walchand College Of Engineering, Sangli(M.S) India

\*\*\*

**Abstract** – Power quality have different definition, depending upon ones frame of reference. Any problem in electrical quantity i.e. in voltage, current, frequency deviation results in failure in the system. There are lots of power quality problem like transients, voltage harmonics, current harmonics, voltage imbalance, long duration voltage variation, short duration voltage variation, power frequency variation etc. This paper presents, problem related to voltage harmonics and simulation model of three phase Series Active Filter (SAF) to mitigate this voltage harmonics problem. Control algorithm is used for three phase SAF is Synchronous Reference Frame (SRF). This SAF is implemented by three phase Voltage Source Inverter (VSI). This model of SAF is developed in MATLAB/SIMULINK environment and simulation results of power quality improvement in the system are presented in terms of Total Harmonic Distortion (THD).

**Key Words:** Power Quality, Voltage Harmonics, Series Active Filter, Synchronous Reference Frame, Total Harmonics Distortion.

## 1 INTRODUCTION

Firstly, this paper introduces what is power quality? Any power problem i.e. problem related to voltage and current that results in failure or misoperation of customer equipment. So, from power equation it is clear that power quality problem is strongly related to voltage quality problem because voltage is controlled by power supply system and current is varied by particular load. Therefore the standard in power quality is maintained by maintaining consistency in supply voltage.

Now a day's power quality is a grave issue in large industry because it directly affect on its profitability, which is definitely impetus to industry. In this fast growing world use of power electronics device, i.e. inverter, cycloconverter, semiconductor device, high voltage drive in traction, rectifier with R-C load, domestic electronic equipment like CFL, computers, fax machine etc. are increase. This load creates disturbance in voltage waveform, produces voltage harmonics. Sometimes this problem may be severe and it can lead to a complete shut off the production in semiconductor plant, which pulls the economic crisis.

In earlier day, this voltage harmonics problem is mitigate by using shunt passive filter. But it is not effective in light load, there is a problem of voltage regulation, at light load. Due to passive element, system suffers from lagging power factor and increases voltage drop in passive element [6]. To

overcome this problem and to provide better compensation here is use advance series active power filter.

This SAF is implemented by three phase VSI. VSI is acts as a controlled voltage source. For controlling these VSI i.e. SAF there are different topologies are used. These topologies are time domain, frequency domain and other new technologies. P-Q theory, instantaneous reactive power theory, SRF theory[4], instantaneous power balance method, balanced energy method, synchronous detection algorithm, notch filter based method are the time domain method. Furrier method is one of the frequency domain methods. Dead beat control, space vector modulation and wavelet conversion are some of the new techniques. In this paper synchronous reference frame topology is used.

SRF topology relies on PARK'S transformation which converts three phase voltage and current variables into a stationary reference frame. The system with this topology is very stable and requires less computation. By using SRF topology, reference signals are generated. Theses reference signal is compared with sensed load voltage and produces a gating signal for switching of inverter. Compensation reference signal is produces by generating proper gate signal for VSI. For that comparison purpose and produces proper gate signal, it is required to use perfect controlling techniques. There are various controlling technique like linear control technique and hysteresis controlling technique, sinusoidal pulse width modulation controller etc. in this thesis hysteresis controlling technique is used.

### 1.1 Synchronous Reference Frame

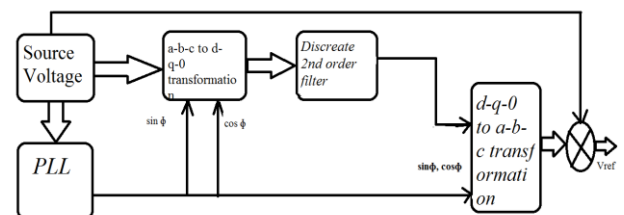

**Fig.1.1 Synchronous Reference Frame**

This proposed control strategy i.e. SRF technique is used in series active filter for generating reference signal. Above fig. shows general block diagram of SRF. In this method three phase source voltage  $V_{abc}$  is given to abc-dq0 transformation, which converts supply voltage  $V_{sabc}$  by equation,

$$\begin{bmatrix} V_d \\ V_q \\ V_0 \end{bmatrix} = -\sqrt{\frac{2}{3}} \begin{bmatrix} \cos(\omega t) & \cos(\omega t - 2\pi/3) & \cos(\omega t + 2\pi/3) \\ -\sin(\omega t) & -\sin(\omega t - 2\pi/3) & -\sin(\omega t + 2\pi/3) \\ 1/\sqrt{2} & 1/\sqrt{2} & 1/\sqrt{2} \end{bmatrix} \begin{bmatrix} V_{sa} \\ V_{sb} \\ V_{sc} \end{bmatrix}$$

Where,  $\omega t$  is the transformation angle and  $V_{sabc}$  is the supply voltage.

In SRF  $\omega t$  is the time varying angle which rotates at constant speed with three phase voltage.

Simultaneously three phase voltage  $V_{sabc}$  is also given to phase locked loop. Phase lock loop is control system that generates an output signal whose phase is related to the phase of an input signal. In synchronous reference frame it is used to generate the transformation angle ( $\omega t$ ) which presents the angular position of the reference frame. It is called as park transformation. The low pass filter is used to obtain reference source voltage in d-q-0 co-ordinates. The output of PLL and low pass filter is given to inverse park transformation, which converts d-q-0 into a-b-c by using below equation:

$$\begin{bmatrix} V'_{La} \\ V'_{Lb} \\ V'_{Lc} \end{bmatrix} = \sqrt{\frac{2}{3}} \begin{bmatrix} \cos(\omega t) & -\sin(\omega t) & 1/\sqrt{2} \\ \cos(\omega t - 2\pi/3) & -\sin(\omega t - 2\pi/3) & 1/\sqrt{2} \\ \cos(\omega t + 2\pi/3) & -\sin(\omega t + 2\pi/3) & 1/\sqrt{2} \end{bmatrix} \begin{bmatrix} V_d \\ V_q \\ V_0 \end{bmatrix}$$

In this way by using synchronous reference frame technique generate reference signal.

### 1.2 Hysteresis Current Control Technique:

Hysteresis current control technique is used for generation of firing signal for switching of VSI. Output of SRF i.e. reference voltage signal is given to hysteresis controller. It is a instantaneous control that forces the APF compensation voltage ( $V_i$ ) to follow its reference signal i.e. voltage reference signal ( $V_{ref}$ ) within a certain tolerance band. Compensation voltage ( $V_i$ ) is measured and then compared with reference voltage signal ( $V_{ref}$ ) and resulting error is used to determine the gating signal. When error is within the hysteresis band no switching action is taken. Switching is taken when error is beyond hysteresis band.

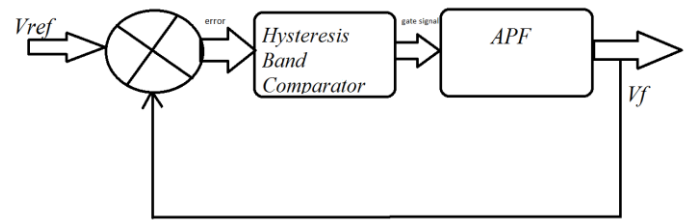

Fig.1.2.1 Hysteresis Controller

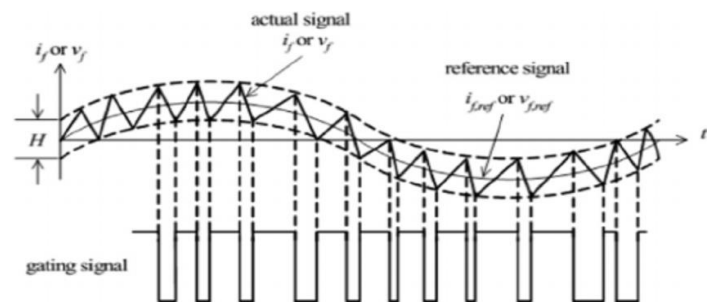

Fig. 1.2.2 Gate signal

## 2. MATLAB SIMULATION Model Of SAF

The objective of this paper to present simulation model of "Series Active Power Filter" for compensation of voltage harmonics, voltage unbalance etc. In this section discuss various simulations model which useful for APF and results related to this.

Fig. 2.1 shows Series Active power Filter with reference signal generator, hysteresis controller, series active filter which is connected through transformer, shunt passive filter and rectifier with R-C. Supply given to this model is three phase 400V.

### 2.1 System Parameter

1	System voltage, Frequency	400V , 50Hz
2	Source inductor	0.20471e-3
3	Transformer Turn ratio	1:1
4	Load capacitor	10 F
5	Load resistor	0.01

### 2.2 Simulation Results

Up till now in this paper discuss control strategy for controlling APF and also see simulation model for APF. Now in this section discuss results of APF by using control strategy synchronous reference frame theory with hysteresis

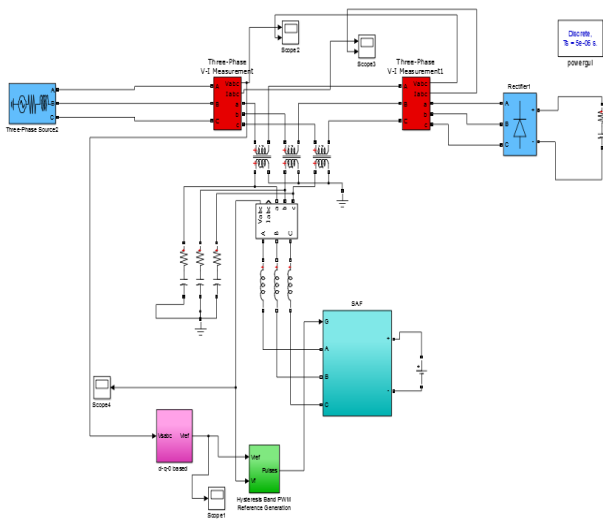

Fig. 2.1 Simulation of APF

Controller. Discuss results under following condition:

- Simulation results without filter and with nonlinear R-C load
- Simulation results with active filter and with nonlinear R-C load

**2.2.1 Simulation results without filter and with nonlinear R-C load**

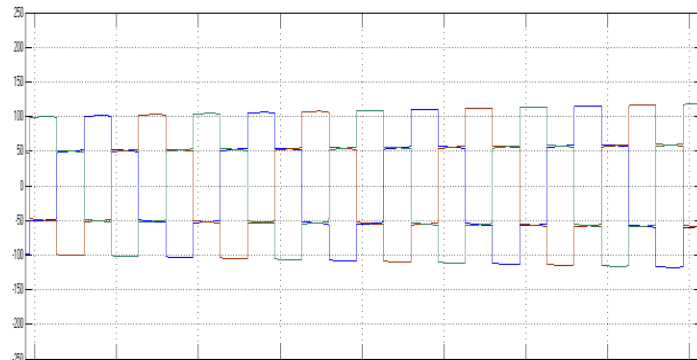

Fig. 2.2.1 a) Source Voltage waveform without APF

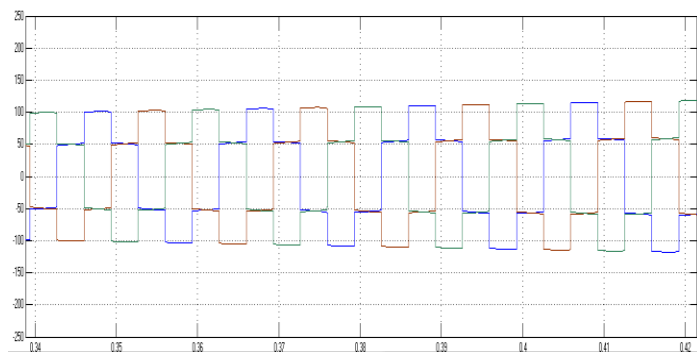

Fig. 2.2.1 b) Load voltage waveform without APF

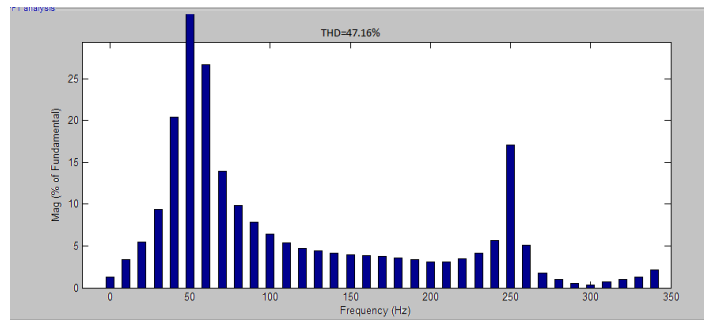

Fig 2.2.1 c) THD of source voltage without APF

**2.2.2 Simulation Results with APF and with nonlinear R-C Load**

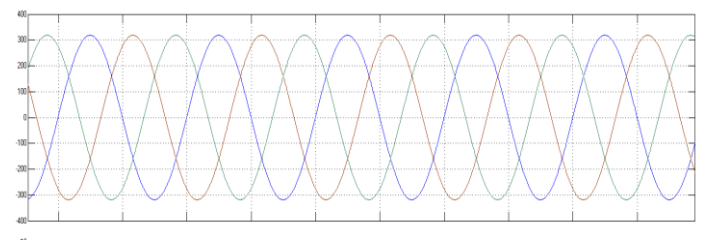

Fig. 2.2.2 a) Source voltage waveform with active filter

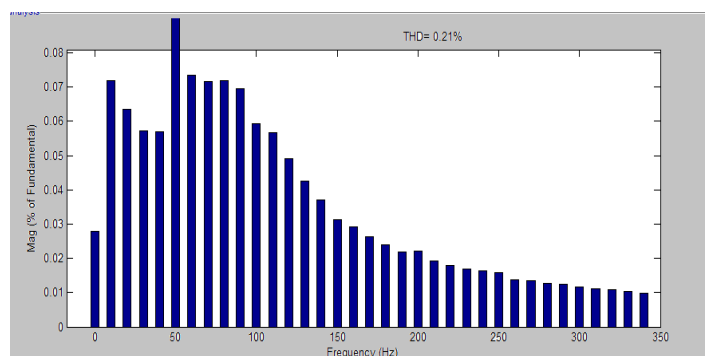

Fig. 2.2.2 b) THD of source voltage with APF

**3. CONCLUSIONS**

This paper presents series active filter for voltage harmonic compensation. By using synchronous reference frame theory and hysteresis controller here design series active filter. And by using this paper compensate voltage harmonics. The series active filter is works as controlled voltage source.

In experimental results, by using series active filter THD is reduced from 47.16% (nonlinear load without compensation) to 0.21% (nonlinear load with compensation).

**REFERENCES**

[1] 1.Mrs. M.A.Chaudhri, Mr. Chandraprakash , “THREE PHASE Series Active Power Filter as Power Quality

Conditioner"2012 IEEE International Conference on Power Electronics, Drives And Energy System.

- [2] Ab. Hamadi, S. Rahmani,-IEEE Member, AL-Haddad Fellow Member IEEE " A novel Hybrid series active filter for power quality compensation" 1-4244-0655-2/\$20.00©2007IEEE
- [3] H. Akagi, Edson Hirokazu Watanbe, Mauricio Aredes "Instantaneous power theory and application to power conditioning"
- [4] D. R. Patil, Member IAENG, U. Gudar, Senior Member IEEE, Devendra L. Raokhande "Performance Od Series-Shunt Power Quality Compensator Under Unbalanced And Distorted Loading Condition" 2013IEEE International Conference On Control Application.
- [5] Y.S.Kim, J.S.Kim, S.H.Ko " Three Phase Three Wire Series Active Power Filter, Which Compensates For Harmonics And Reactive Power" IEE Proc-Electr. Power Appl. Vol 151, No. 3 May 2004
- [6] Pranjali Bafila " Power Quality improvement using shunt passive filter" Internaional Journal Of Enhanced Research in Science Technology & Engineering Vol.4 Issue 6. Jun 2015.

conference and 15 national conference / seminars publications. He conducted 3 workshops and 3 training programs in the institute. Also, he has attended 12 summer / winter school. His areas of interest are control systems applicable to power system.

## BIOGRAPHIES



Priyanka Shintre aged 26 has obtained her B.E in Electrical Engineering with first class with distinction 2012 from Shivaji University Kolhapur (M.S). She is perusing M.E in Electrical Power System from university. This work has been carried out as a PG research holder. Her areas of interest are power system, Energy Conservation, and power quality.

Dr. D.R.Patil aged 60 has obtained his B.E in1981. M.E in 1985 and Ph.D. in 2013. He started his teaching career from1985, as a lecturer in Electrical Department of Walchand College of Engineering, Sangli (M.S). Subsequently in 1993 he promoted as a assistant professor of control system on the post graduate. He has been actively associated with teaching various subjects of control system as well as power system at post graduate level. He has guided almost 70 dissertation / project at post graduate level and about 30 projects at under graduate levels. He has about 20 international