

# Autonomous Fire Extinguisher Robot

Varun S V<sup>1</sup>, Vinod Rao V<sup>2</sup>

<sup>1</sup>Varun S V, Student, Dept of ECE, APSCE, Karnataka, INDIA

<sup>2</sup>Vinod Rao V, Student, Dept of ECE, APSCE, Karnataka, INDIA

\*\*\*

**Abstract** – A Robot which can be deployed immediately to the place where the fire mishap has started is a first aid to the entire situation. This paper refers to the very same idea, using flame, smoke and gas sensors in a room and deploying a robot guided by ultrasonic sensors, and flame sensors are mounted on the robot in a graduated scale which allows larger area coverage, a stepper motor to direct the hose in the desired direction and a water pump to sprinkle out the water through the hose.

**Key Words:** Ultrasonic sensor, Fire mishap, Flame sensor, Multilevel, Extinguish.

## 1. INTRODUCTION

In day to day life every household is exposed to electrical, plastic, flammable liquid and other types of fires. The risk of allowing this fire to grow throughout the household or in a small scale industry is very devastating and chaotic. Every fire mishap has its own consequences, to eliminate these effects we are proposing a innovative idea of a economical, compact and self sufficient robot which can locate, detect and extinguish fire on the concepts of basic robotics and communication.

### 1.1. Problem Definition

The common conventional fire fighting methods involve fire brigades, portable fire extinguisher (hand held) and sprinklers. These conventional methods consume lot of time to reach the place of the mishap like the fire brigade must be deployed from the fire station and should get through the traffic and reach the fire struck area, the portable extinguisher is also no gift because it is generally place at one off the corners of the building which may be difficult to reach and it needs constant maintenance. On the other hand the sprinkler and smoke detector set up is very non reliable method because the sprinkler pipes has any defect may not provide enough pressure and it is suited to cover large areas.

For the above mentioned disadvantages a robot with its own decision making capabilities and with a very high impact factor can make a fire prone area get the first aid required.

## 1.2. Objective

1. To develop a transmitter which can sense the presence of flame, gas and smoke and give a initiate signal and intimate the fire station.
2. To create a self sustainable robot that is capable of detecting and extinguishing fire.

## 2. Literature survey

### 2.1. FINE( First Intelligent Extinguisher)

FINE is an intelligent fire extinguisher designed to effectively fight against a domestic fire. It can be easily used as a traditional fire extinguisher by an individual. Also, it can alert the fire fighters if a fire takes place when nobody is at home and starts putting out the fire automatically until the fire fighters involves with the situation. This compact product contains an infrared thermometer to sense flames, a rolling base, a container of powder and collision sensors to evade obstacles. It comprises a usual smoke detector and moves towards the fire to pulverize the powder into the core of the fire.



Fig -1. FINE (Future Intelligent Extinguisher)

The tank capacity of Fine is of 1.5 liters which is less and the robot can only go through flat surfaces and cannot move through other terrains.

### 2.2. Thermite

In 2012 Howe and Howe Technologies of Waterboro, Maine, has unveiled the firefighter of tomorrow called the Thermite RS1-T2. Based on technology developed for the U.S. Army, this squat little modular robot on tank treads is a small, powerful fire fighting machine that provides crews with a means for remote reconnaissance and fighting fires in hazardous areas safely. The Thermite is designed to be used in areas of extreme hazard, such as aircraft fires, refineries, chemical plants or nuclear reactors and also its

compact size makes it feasible to take it into a building or can be carried through a elevator.



Fig-2. Thermite

The size of Thermite makes it impeccable to store it any home and it does not contain a built in tank, hence requires a source of water to be fed into it. The cost of one such Thermite is approximately INR 95lakhs which makes it non affordable for household use.

### 2.3. Voice Operated Intelligent Fire Extinguisher Vehicle

Voice Operated Intelligent Fire Extinguishing Robotic Vehicle can be controlled by RF communication. The vehicle is controlled through User Voice Command. The voice input allows a user to interact with the robot which is familiar to most of the people. It can also sense the temperature which has self-defensive ability so that there will be no more harm to the robot.



Fig-3. Voice Operated Intelligent Fire extinguishing vehicle.

This robot must be in sight of the user to control which is not possible at all times during a fire mishap. The tank capacity of this is two liters which is not sufficient for a medium fire. The power required to drive a water pump used in this project is very high.

### 2. The Onboard Brain

The system requires two parts one to initiate the robot and the second the robot itself. The common part on both the sides is a microcontroller and it acts as the heart of the

system. All the other peripherals perform data transfers through analog or digital means.

### 2.1 Transmitter

The transmitter is placed in the building where there is a possibility of a fire mishap. The entire setup will consist of a microcontroller, flame sensor, gas sensor, smoke sensor and a RF433Mhz transmitter which performs the transmission of data

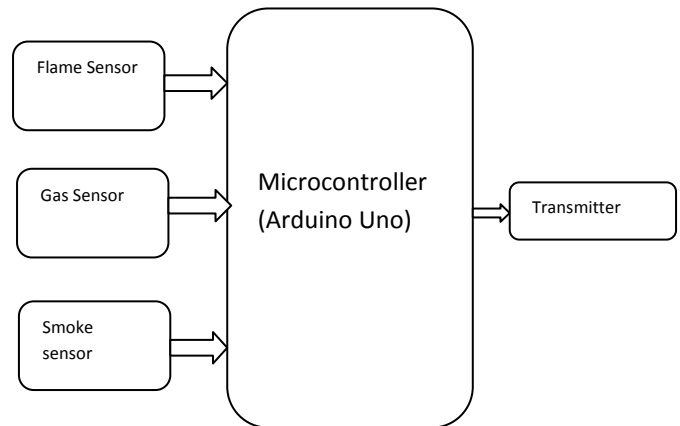
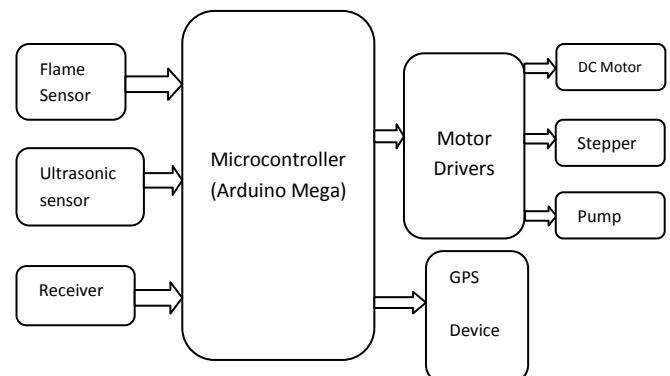

Fig-4. Block diagram of Transmitter

### 2.2 Receiver (Robot)

The receiver consists of 2 parts, the first part constitutes an Arduino Mega board which is operated with a Atmega2560 microcontroller this board is used to inculcate any further modification to the robot. The Mega board contains 54 digital i/o pins and 16 analog i/o pins and a quartz crystal of 16Mhz for clock. The receiver uses five flame sensors in specific directions to cover maximum area at a shot and ultrasonic sensors for avoiding any obstacle in the path and a RF433Mhz receiver. Motors are used for locomotion of the robot and a water pump to pump out water. The 2nd part consists of an LED Cluster installed at regular intervals.



### 3. WORKING

To overcome the problems in the existing systems the Autonomous Fire Extinguishing Robot comes

equipped with flame sensors placed on a graduated scale that covers complete 360°.

The transmitter installed at the disaster prone area initiates the robot that is placed in the station within the building and the robot takes the default (pre determined) path where the transmitter is placed the robot then does the detection and extinguishing of fire, it also comes equipped with 3 ultrasonic sensors that help the bot to avoid obstacles at the site.

The tank capacity of four liters allows the robot to eliminate a medium fire.

A very loud siren alerts all the neighbours regarding the incident.

The tank of the robot can be refilled in the station by adapting a flow control valve and a water level indicator. The doors of the building will have a master control such that the doors automatically open when fire is detected in the building so that the robot can enter into the affected area.

The compact size of this robot can be housed in any small corner of the building

Narrowing down the focus to multistoried buildings, an LED Cluster corresponding to each subset of the building is installed at every floor (as in case of apartment building each LED corresponds to each house and is fitted in every house).

In case of a fire mishap the corresponding LED glows and thereby conveying information throughout the building.

Also a GPS device conveys information regarding the location of the affected area so that the firemen have first hand information regarding the incident.



**Fig-4.** Autonomous Fire Extinguisher Robot

## 4. IMPLEMENTATION

The implementation of the proposed system is done at both hardware and software levels. The complete functional system is obtained once the hardware and software module are interfaced for the proposed application.

## 4.1 HARDWARE TASKS

The hardware tasks can be divided into three viz. flame detection, water sprinkling and Ultrasonic range finder.

### 4.1.1 Flame Detection

Three flame sensors are placed in the front and are interfaced with the Arduino board to judge where exactly the water must be sprinkled and the three sensors have a response to wavelengths of 760nm-1100nm and to flames.

These sensors are given the first priority and immediately after the fire is sensed the vehicle is made to stop and the control is given to the pump to sprinkle water with the help of a pump and for movement of the hose a stepper motor is used.

### 4.1.2 Obstacle Detection Module

The automation is made successful by the use of an obstacle detection code which takes in the input through an Ultrasonic sensor.

The obstacle detection is carried out using a dual transducer SRF05 Ultrasonic Range Finder Sensor. Once triggered, the ranger produces an eight cycle sonic burst at 40 kHz frequency.

Simultaneously the echo pulse is raised high until the last sonic pulse sends back the reflected wave. Once the duration of this echo pulse is found, distance can be easily calculated using this time and the speed of sound. The actuator is controlled based on the distance calculated, i.e. whether the robot must be driven forward or change the course (right or left).

### 4.1.3 Motor Drivers

The robot's movement must be controlled based on the conditions in the code with the response of the obstacle detector. Actuators cannot be driven with the supply provided by the microcontroller output pins. Motor drivers (L293D) are interfaced with the microcontroller (Arduino) so as to provide the actuators the required driving current. The motor drivers require a second external supply which acts as a supply to the H-bridge amplifier. The control signals control the action of the motors, i.e. whether the motor must be driven clockwise or anti clockwise. The motor drivers are used to boost current for the water pump as well.

## 4.2 Software Tasks

The software tasks include designing and developing a suitable algorithm for the entire proposed system. According to the logic of the algorithm, a suitable code is developed that is dumped onto the processor board, in this case the Arduino board. Once the code is dumped on the processor, the implementation is monitored.

### 4.2.1 Flow chart for sensing fire

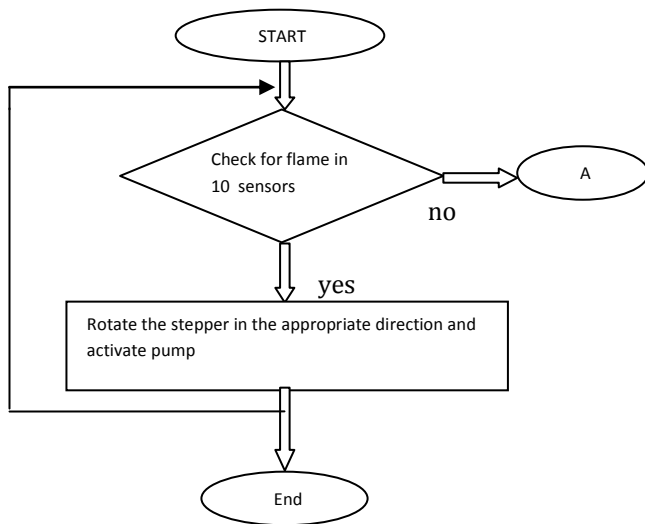

Fig-5 Flame sensor flowchart

The flame sensors are placed in three positions and all the three are monitored and if a flame is present in the surrounding, the range till which the flame can be detected depends on the range of sensor the code is written based on the flowchart and flame sensor is given the highest priority. The value is provided in the code below which if the reading drops below it is assumed that there is a fire. The hose is moved accordingly to the direction where the fire is detected and the pump is activated to sprinkle the water.

### 4.2.2 Flowchart for Obstacle Detection

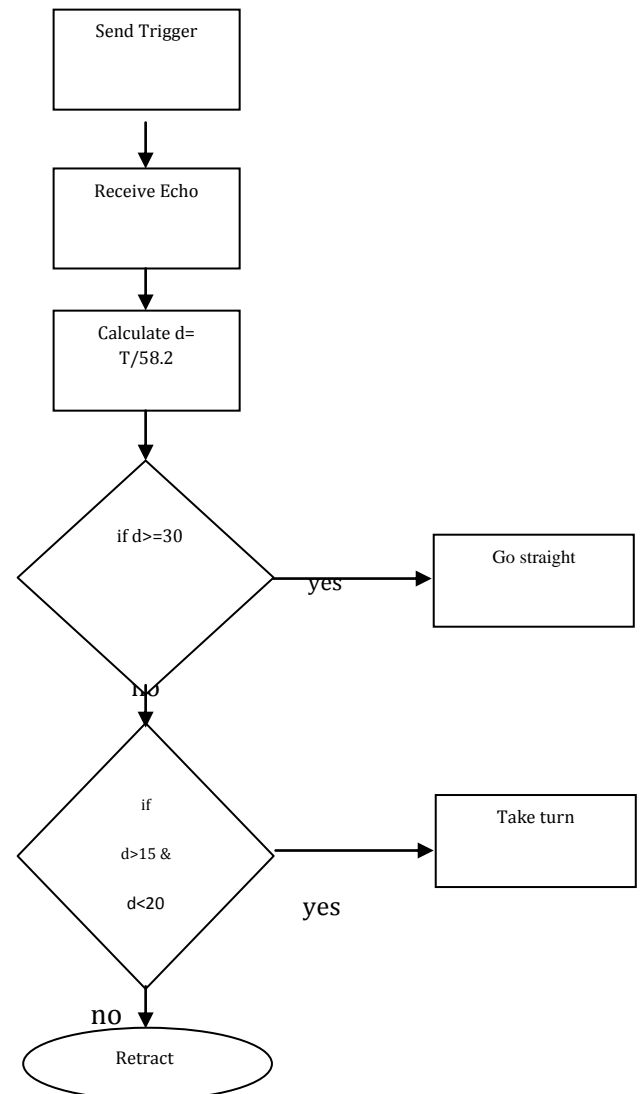

Fig- 6 Obstacle avoider flowchart

### 4.2.3 The LED Cluster



Fig-7 An LED Array

The LED Cluster is a very important add-on to know where the fire mishap has occurred. The corresponding LED glows when there is fire in that area for which the LED is associated.

#### 4.2.4 The Fire Siren



Fig-8 A fire Siren

The Fire Siren is an important part in conveying information regarding fire. Without the siren the probability of the getting to know that the fire accident has taken place will slim down drastically. Without the siren the LED may glow but since one is engrossed in work he wouldn't notice it.

#### 4.2.5 The GPS Module



Fig-9 A popular GPS Module

The GPS Module Conveys information regarding fire to the fire station as soon as the fire is detected. The firemen can immediately proceed with the successive steps necessary to avert a major fire accident.

### 5. Advantages

- Can be used in small scale industries and homes where there is a chance of fire mishap to start as it

can be helpful as the primary aid for fire extinguishing.

- Can be used to cover a larger area when put in action, as it has 10 flame sensors whose coverage is 360°.
- Very useful in conveying information of the fire mishap.
- Multilevel Information conveyance.
- Cost Effective.
- Firemen get instant information and hence further development can be averted.

### CONCLUSION

A small fire left untreated leads to a bigger one. The Proposed system will indeed be useful in fighting fire with multilevel information conveyance capabilities so that a bigger disaster can be averted. Lets bend the sapling instead of trying to bend a big fully grown tree.

### REFERENCES

- [1] Boo Siew Khoo, Siew Wen Chin, Leong Yee Soo, Edwin Chuah, "FireDroid- An Automated Fire Extinguishing Robot", 2013 IEEE International Conference on Control System, Computing and Engineering, 29 Nov. - 1 Dec. 2013, Penang, Malaysia
- [2] Madhavi Pednekar, Joel Amanna, Jino John, Abhishesh Singh, Suresh Prajapati, "Voice Operated Intelligent Fire Extinguishing Vehicle", 2015 International Conference on Technologies for Sustainable Development (ICTSD-2015), Feb. 04 - 06, 2015, Mumbai, India