

## Women’s safety using IOT

**Prof. R.A.Jain<sup>1</sup>, Aditya Patil<sup>2</sup>, Prasenjeet Nikam<sup>3</sup>, Shubham More<sup>4</sup> , Saurabh Totewar<sup>5</sup>**

<sup>2,3,4,5</sup>Electronics and telecommunication Dept.,Sinhgad Academy of Engineering,  
Savitribai Phule Pune University,India.

<sup>1</sup>Professor,Electronics and telecommunication Dept.,Sinhgad Academy of Engineering,  
Savitribai Phule Pune University,India.

\*\*\*

**Abstract** - Nowadays, women and children safety is a prime issue of our society. The count of the victim are increasing day by day. In this paper, We are proposing a model which will help to ensure the safety of women and children’s all over the global. We have used different sensors like heartbeat sensor, temperature sensor, accelerometer sensor for detecting heartbeat, temperature and sudden change in motion of user. We have also used GPS which will help to detect location of the device. GSM used in the model is used to send alert message to guardians, relatives and police station. We have proposed IoT(internet of things) based device which will help to continuously monitor values of different sensors and GPS used in device.

**Key Words:** IoT, Microcontroller, HELP , GSM, GPS, sensors.

### 1.INTRODUCTION

At the present scenario Women are competing with men in every prospect of society. Women contribute fifty percent to the development of our nation. But the women have fear of getting harassed and killed. All these types of women harassment cases are increasing day by day. So it is very important to ensure the safety of women.

In this paper proposed model of a band will provide a required safety to women so that they can do late night work. Proposed model contains various sensors which will measure different parameters continually. IoT (internet of things) is relatively new and fast-developing concept. By using IoT-based technology guardians, relatives and police can monitor and track different sensors value and position of a device. A device is wearable and so it is easy to carry.

### 2. Block Diagram

Block Diagram is divided into two sections :

#### 2.1 Transmitter:

Power supply: 5v supply is used for Microcontroller, gsm and gps module while 3.3v power supply is used for various sensors. Sensors will continuously send their values to microcontroller. Microcontroller will compare readings of sensors with threshold values. Microcontroller will generate “HELP” message accordingly. GPS attach to microcontroller

will track the position of the device. GSM attached to Microcontroller will send message to contacts stored in SIM.

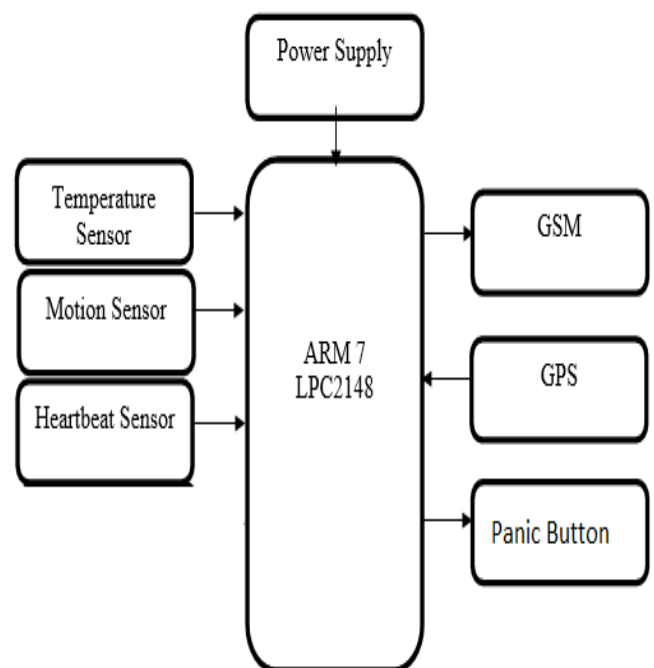

**Fig-1:** Transmitter Block diagram

Panic button is provided for emergency alert. When Panic button is pressed gsm will urgently send “HELP” message without comparing to the threshold values.

#### 2.1 Receiver:

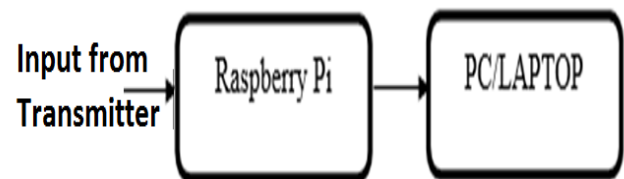

**Fig -2:** Receiver Block Diagram

Receiver is used for checking the values of sensors. Raspberry Pi or laptop can be used to process and display values of sensors and position of device. End device which is being used for display should be connected to internet.

### 3. Hardware:

Hardware component used in device are as follows:

**i) Microcontroller:** Any ARM 7 microcontroller having two UART ports can be used. In proposed model we have used ARM 7 LPC2148. LPC 2148 is 32/16 bit RISC microcontroller. It has two 10 bit ADC with 14 channel. It also has two UART port which used for GSM and GPS systems.

**ii) Raspberry pi:** Raspberry pi is single board computer. Its CPU speed ranges between 700MHZ and 1.2 GHZ. It also has on board memory between 256 MB and 1GB Ram. This is used at receiver to display values and position in terms of latitude and longitude.

**iii) GPS:** GPS stands for global positioning system. GPS is used to track the device. GPS gives a position of a device in terms of latitude longitude and altitude. GPS is used to track moving device using satellite signal. When GPS is used there is communication between GPS transceiver and GPS satellite.

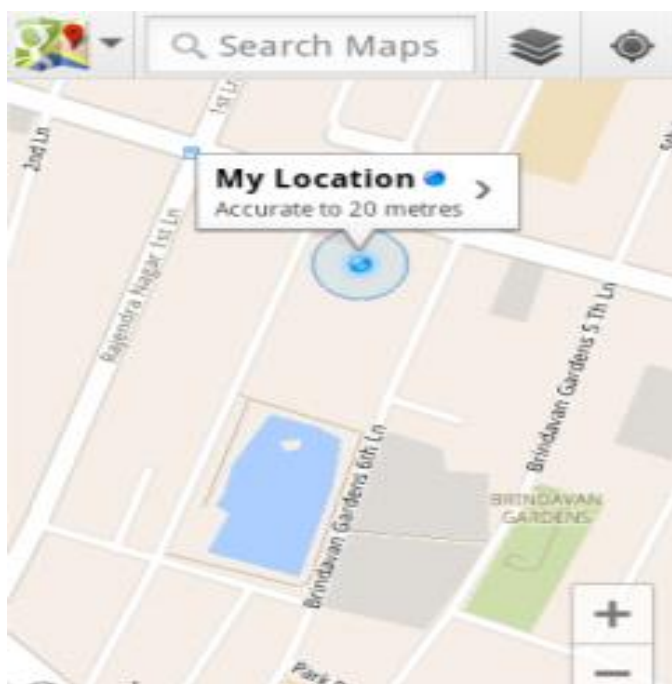

Fig-3: GPS location on map

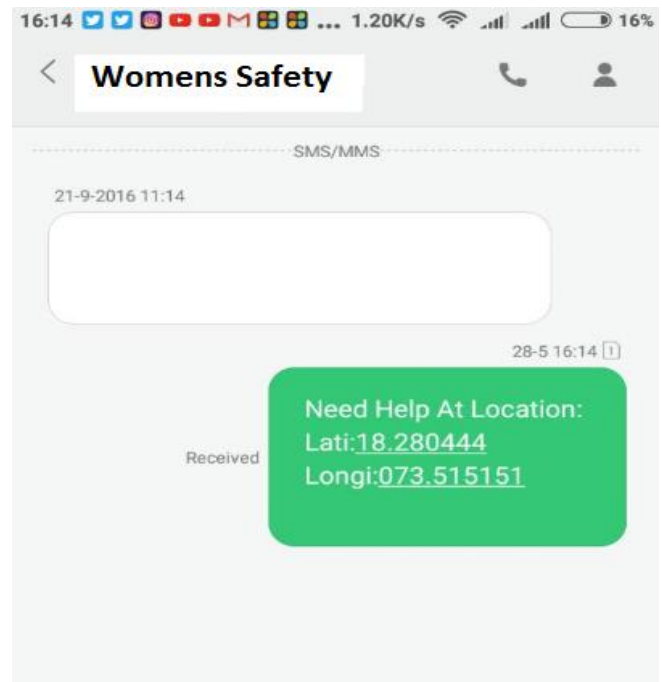

Fig -4: Sample sms

**iv) GSM:** GSM stands for global system for mobile communication. GSM is a cellular technology which is used for voice and data transmission. GSM operates in-band of 900 MHz to 1.8 GHZ. Through GSM it is possible to transmit SMS.

### 4. Working:

Proposed Model is wearable model. After giving power supply to device , sensors on device will start taking readings. This readings are continuously sent to microcontroller. Microcontroller will compare this readings with the threshold values given to it .This threshold values can vary from person to person. After comparing this threshold values , Microcontroller will send "Help" message accordingly. GPS is used in device to continuously track device. Using IoT technology we can continuously monitor changes in sensors values. Position of device can also be track continuously. At the receiver side device like laptop, mobile phone, raspberry pi etc can be used to see sensor values and position. The device at receiver should be connected to internet in order to receive data from transmitter.

### 5. CONCLUSIONS

The proposed system is to ensure the security of the women in the society by providing automatic sensing of threats and send the "HELP&POSITION" to the relatives and the Police Station using Internet Of Things.

## REFERENCES

- [1] Vamil B. Sangoi, "Smart security solutions," *International Journal of Current Engineering and Technology*, Vol.4, No.5, Oct-2014.
- [2] Simon L. Cotton and William G. Scanlon, "Millimeter - wave Soldier -to soldiercommunications for covert battlefield operation," *IEEE communication Magazine*, October 2009.
- [3] Alexandrous Plantelopoulous and Nikolaos.G.Bourbakis, "A Survey on Wearable sensor based system for health monitoring and prognosis," *IEEE Transaction on system, Man and Cybernetics*, Vol.40, No.1, January 2010.
- [4] B.Chougula, "Smart girls security system," *International Journal of Application or Innovation in Engineering & Management*, Volume 3, Issue 4, April 2014.