

Distributed Cable Harness Tester

Prof. R. B. Kakkeri¹, Laukik Inamdar², Shubham Bhambare³, Akshay Gund⁴

¹Assistant Professor, Dept. of Electronics and Telecommunication, Sinhgad Academy of Engineering, Pune, India¹

^{2,3,4}Student, Dept. of Electronics and Telecommunication, Sinhgad Academy of Engineering, Pune, India

Abstract - A harness is assembly of cables or bunch of wires used for transmitting electrical power to the receiver electrical unit. The cables are bound together using straps or flaps forming an assembly of cables. Automobile, military, navy and aerospace use harness tester to find defects in cables before the defects damage the equipment and make it unuseful or waste beneficial technician time. The harness tester performs

testing for interconnection on cables for wiring correctness and insulation quality. Defective end is recognized using controller and it also identifies wiring defects and it's on board location of the product. These testers are easy to use, accurate, time efficient thereby saving a lot of technician time involved in manual checking. Harness testers have patented and unique graphic display for displaying the wiring errors detected. The tester offers quick pass/fail testing under time instant of around one second for production environments. Intermittent-connections are identified in the cable and displayed accordingly. System consists of mounting jig, tester controller, port expander, PC, Ethernet etc.

Key Words: Harness, Intermittent, ARM, Cable Testing, Port Expander.

1. INTRODUCTION

There is no such device that can perfectly test a cable for its working condition. Harnessed cables are often short circuited, open circuited or have interchanged connections. This system provides the best solution to these problems. It is time efficient, requires less manpower and a general purpose system. Testing for intermittents in cable and harness assemblies. There are three basic problems that occur in wire harnesses: opens, shorts and mis-wires. Since wires generally don't change location by themselves, intermittent shorts and opens are the problem. Intermittent Shorts means failures in insulation between conductors that should be isolated. Intermittent opens/high resistance connections means failures in the continuity of a conductor. Intermittent problems in the wire itself.

1.1 Objective of proposed work

The main objective of this work is to test a harness for its proper function and to design and develop a testing system that tests a harness upto 16 pins. It is a time efficient device that can test many number of harness within a short interval of time. It is a real time system having less latency desinged for distributed cable testing.

2. LITERATURE SURVEY

Very less work is done in the field of automobile cable testing. Previously, the work done is based upon CAN and I2C Protocols respectively. Earlier a single cable testing was performed but multiple cables can be tested simultaneously. The following research papers describe the earlier work done in the design and development of cable harness tester.

[1] this paper discusses a distributed cable harness tester based on CAN bus, which has a few functions such as connection detecting of a wire, diode orientation testing and resistor's impedance testing. The proposed work is based on CAN protocol but instead we are using simpler protocol, SPI protocol.

[2] Deals with continuity testing of the backplanes in production which would be tedious and error prone without an automated and standard test infrastructure. From this literature we have adopted testing methodology of cables.

[3] Presents a platform which deals with the implementation of certain of serial protocols presented by a low power 32-bit ARM RISC processor LPC2148. This platform is also useful for students of different disciplines to work with different serial protocols, which helps them in interfacing of sensors, memory ICs, analog subsystems and so on. We have studied the serial peripheral interface protocol and implemented the same in our device.

3. SYSTEM DESIGN AND IMPLEMENTATION

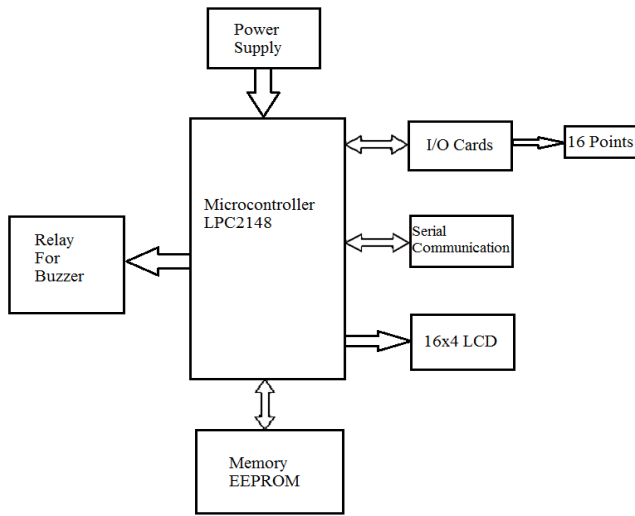

Fig-1: Block Diagram

The major components of the system are as follows:

- ARM Microcontroller LPC2148
- MCP23S17 (I/O Cards)
- EEPROM (Harness Data Storage)
- LCD (16x4)
- Relay

3.1 ARM Microcontroller LPC2148

The 32/16 bit LPC2148 microcontroller has embedded trace support and real-time emulation. The high-speed flash memory of this controller ranges from 32 kB to 512 kB and 512kB of SRAM memory. Its unique accelerator architecture supports 32-bit code execution at maximum clock rate with wide memory interface of 128-bit. The alternate 16-bit Thumb mode with minimal performance penalty reduces code by more than 30 % in critical code size applications. It has a 32 kHz low power clock input. The controller consists of 47 GPIO pins and 32 bit timer/counters. It operates at 1 to 50 MHz external crystal and 3V to 3.6V voltage range.

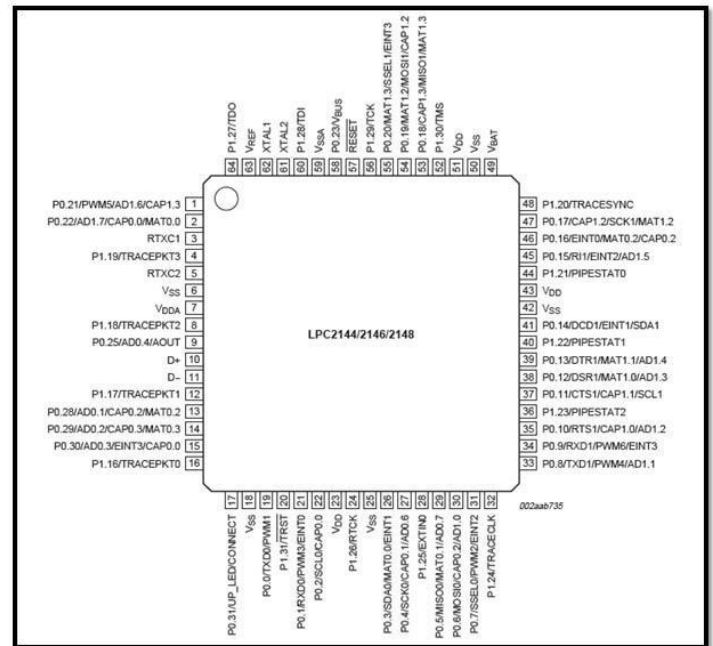

Fig-2: Pin description diagram of LPC2148

3.2 MCP23S17 (I/O Cards)

The I/O pin expansion for serial protocols can be done using MCP23017/MCP23S17 (MCP23X17) device family. It provides general purpose parallel I/O expansion of 16 bits. The input, output and polarity is selected using multiple 8-bit configuration registers. By writing the I/O configuration bits (IODIRA/B) the master enables I/O as either input or output. Input or output register stores the corresponding input or output data. Polarity Inversion register is used for inversion of input port register. System master can read all the registers.

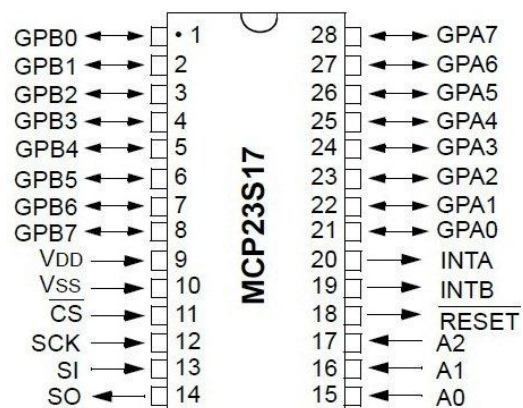

Fig-3: Pin diagram of MCP23S17

3.3 EEPROM (Harness Data Storage)

The IC 24C04A is a 4K bit Electrically Erasable Programmable ROM. The device consists of two wire serial interface organization. The power consumption is reduced with the help of advanced CMOS technology. Write protection is provided using a special hardware feature for upper half of the block. Page write capability of up to eight bytes is provided in 24C04A IC. A maximum of four 24C04A devices can be connected to the same two wire bus.

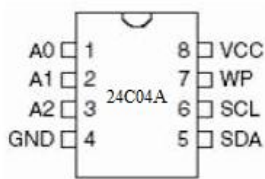

Fig-4: Pin diagram of IC 24C04A

4. SYSTEM WORKING

The working of the Harness Tester for cables is divided into three parts:

- 1) Mounting of harness.
- 2) Loading of standard data of harness.
- 3) Testing.

1) Mounting of harness: The 16 point harness to be tested is mounted on to the zig. The end points of the harness are connected to the respective input/output zig.

2) Loading of standard data of harness: Every harness has its specific data having point to point connections. The harness to be checked is verified according to the standard data, this data is loaded into the memory using serial communication through commands.

3) Testing: The mounted harness is tested as per the standard loaded data. The testing includes open point, interconnected point and wrong connections

i) Open point: Open point is when the connection between the required two points as per the standard connection is absent. All points of the harness are tested for open point one after the other.

ii) Interconnected point: The two points are said to be interconnected when the connection between them is altered. For example there are two pairs 1,16 and 2,15 as per the standard point connection, now 1 is connected to 15 and

2 to 16 such connection is referred to as interconnected point.

iii) Wrong connection: If the connections between two points are not as per the standard defined data then it is termed as wrong connection.

All points undergo above tests, if the harness passes all the above tests, it is referred as successful harness.

4. 1 WORKING FLOW

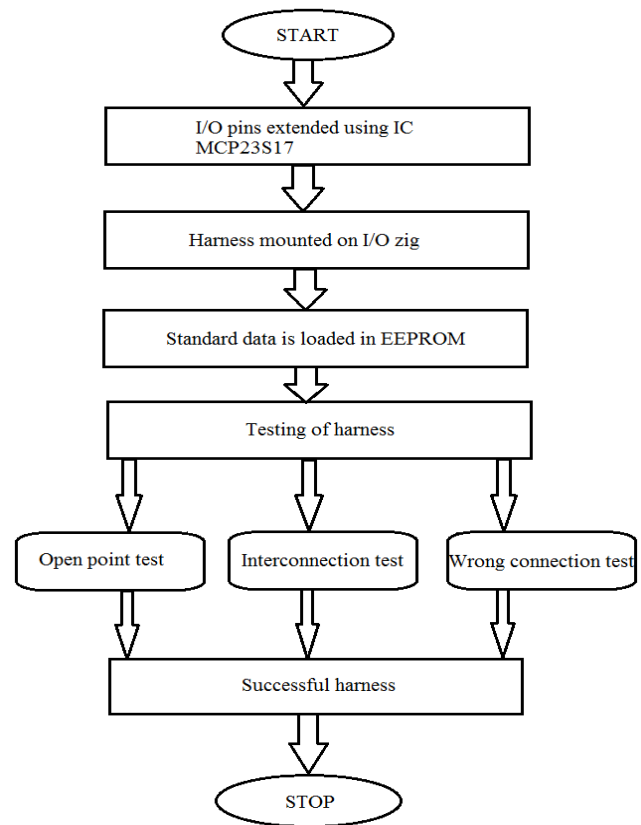

Fig -5: Flowchart of working

5. CONCLUSION

The distributed harness tester will be able to test three connection errors, such as open circuit, interchanged connections and wrong connection. When the harness is mounted tests are performed with the help of microcontroller. This is a unique, compact and low cost device for testing and assembling point to point cables. Tested cables provide efficient connections in the automobile industry. Testing before hand reduces faulty implementation and error generation, thus minimal time consumption. This project concludes successful harness testing for automobile application.

6. FUTURE SCOPE

Harness tester can be made fully automated using GSM module in the assembly thereby saving the precious technician time. Manual mounting of harness data is done which requires a person to always govern the device for loading the respective harness data, this can be avoided by using a GSM module with the help of which data can be mounted onto the device using internet from any corner of the world with internet connectivity.

ACKNOWLEDGEMENT

We express our gratitude towards our teachers for guidance and assistance for our work. The continuous support and encouragement has helped us to get through all the obstacles related to work. We would like to thank our Prof. R. B. Kakkeri for guiding and enriching new ideas. We are also grateful for her regular availability.

REFERENCES

- [1] Mingui Gong and Yutao Dong "A distributed cable harness tester based on CAN bus" Published in: Electric Information and Control Engineering (ICEICE),2011. DOI:10.1109/ICEICE.2011.5777720
- [2] Hayrettin Kesim "Automated continuity testing of flexible backplanes using cable tester"
Published in: IEEE AUTOTESTCON, 2015. DOI:10.1109/AUTEST.2015.7356501
- [3] Aruna Kommu and Raghavandra Rao Kanchi "Desingning and learning platform for the implementation of serial standards using ARM microcontroller LPC2148"
Published in: Recent Advances and Innovations in Engineering (ICRAIE), 2014. DOI:10.1109/ICRAIE.2014.6909185