

# AUTOMATIC CASHLESS CAMPUS STORE USING FINGERPRINT TECHNOLOGY

Ron Mathew Vincent, <sup>1</sup>Rony Thomas<sup>2</sup>, Rajesh Ramanan<sup>2</sup>, Anjalymol Abraham <sup>2</sup>, Mathew C A

<sup>1</sup>Asst. Prof. E.C.E Dept. BTC CET Koothattukulam, Kerala, India

<sup>2</sup> B. tech students, E.C.E Dept. BTC CET Koothattukulam, Kerala, India

**Abstract** - Today we live in a cashless era, where we don't want to carry cash to buy any product. So this technology is implemented to bring in the concept of cashless in educational institutions through automatic cashless campus store using fingerprint technology. This technology enables valid users to purchase necessary products like books, pen, pencil etc., from this machine at any time without holding any money in their hand. This technology mainly uses fingerprint and GSM module for communication with the system. This machine is an advancement of other vending machines, where this machine can sell multiple products. Here the details of payment and the information regarding each user is stored in the fingerprint. So we just need a scanning of our finger to further proceed with the purchasing.

**Keywords:** Fingerprint, GSM, LCD, RFID, Cashless.

## 1. INTRODUCTION

This vending machine is used to sell products like books, pen, pencils etc. to students in education institutions. The main purpose of this technology is to implement the concept of cashless in schools and colleges. In today's world people do transactions digitally, so to make the campus cashless the introduction of the technology named automatic cashless campus store really helps. Here the system works basically of fingerprint technology. The fingerprint technology [4] is adopted in the system because fingerprint of each user's is unique so this helps in bringing very high security to this system.

Automatic cashless campus store is an advancement of existing vending machines, the existing vending machines mainly used to sell chocolates, newspaper, cool drinks etc. in all these vending machines there is only a single product is being sold and the payment of all these products is being done either through coins or cards. But this vending machine is capable of selling multiple products like books, pen, pencil etc. Apart from other vending machines [3], which sells only a single product, payment is done in this machine is through the scanning of each users fingerprint, which is not the case with

other vending machines, where the payment is done either through coin or cards.

All the information regarding the user like name of the person and amount to purchase is stored in the fingerprint. As this system can only be used in campus, the enrolment of each users fingerprint is done during the time of admission. So whenever we need to buy a particular product through this machine, it just needs a scanning of the users fingerprint. The fingerprint module scans the fingerprint of each user and authentication of each user is done, if the user is valid he can proceed with the purchase. In case of invalid user, the access to the system is denied.

As the available balance in the user account is low, a notification message is being sent through each user's mobile number. This is done with the help of GSM module [1] incorporated in the system.

As the vending of products is done automatically, this is achieved with the cd drive mechanism which is commonly seen in our computers. This mechanism used in this system helps in delivery of each product that has been ordered by each user.

## 2. RELATED WORKS

### 2.1 REAL TIME EMBEDDED BASED DRINKING WATER VENDING MACHINE.

This vending machine is used to give drinking water automatically. [5] The payment used in this system is by using coins. Whenever a person needs to have water, this machine automatically supplies water depending on the payment done.

### 2.2 FOOD VENDING MACHINE FOR SCHOOLS.

This vending machine [6] is used to provide meals to poor people who are suffering from financial crisis. This machine is based on fingerprint technology, which contains the

information of each students registered. It provides the easier way to deliver the meals to students.

### 2.3 FARE PRICE SHOP VENDING MACHINE

This vending machine [7] is used for the fare distribution of ration materials to the consumers. This technology uses RFID technology [2] and GSM communication technology. The products can be delivered more accurately with this system and malpractices can be avoided.

### 3. PROPOSED SYSTEM

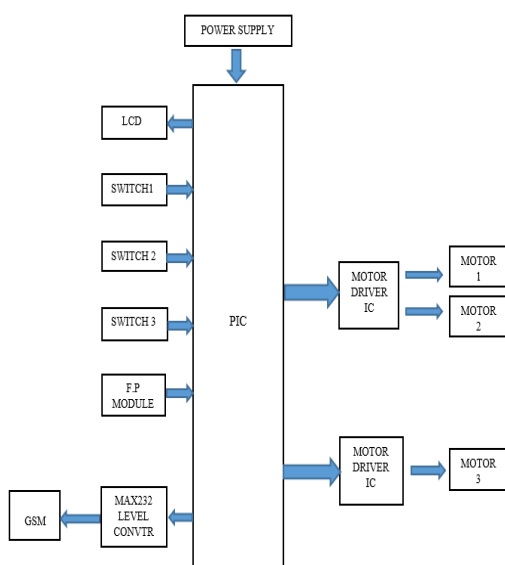

Fig.3.1 block diagram of vending machine

This system starts working by the scanning of the fingerprint of each users with help of the fingerprint scanner, here the authentication of each user is being done. If the user is a valid one then he/she can proceed with the purchase, in case of invalid user the access to the system will get denied.

If the user is proven to be a valid user then the display board will display the name of the person including his /her balance in account.

After displaying each individuals details then the items to be sold out and available quantity of each item are displayed on the LCD display.

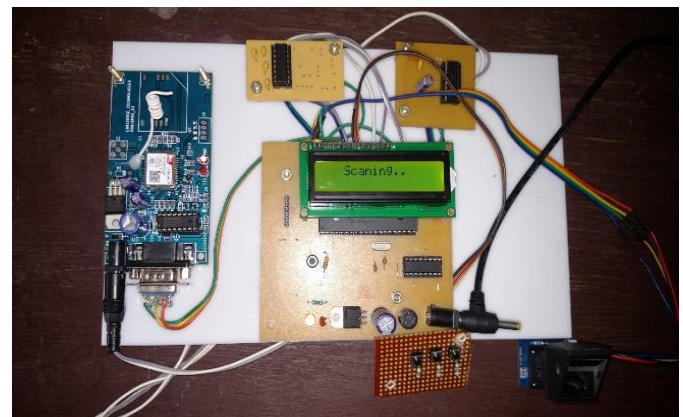

Fig.3.2 Hardware implemented on board

For selecting any item displayed switches are provided for each item, by pressing the switch the item selected will get dispensed through the cd drive mechanism used in the system and the product will be collected in the tray. If a person require more number of products of each quantity then he/she can press the switch that many times.

If the balance amount left in the account is empty, then the notification regarding the low balance will be send to the valid mobile number provided by the user during the time of enrolment.

### 3.1 EXPERIMENT RESULT

Upon the authentication of the user, the details of the user are displayed on the lcd display. Then the list of items to sell are also displayed on the lcd. The user can purchase the desired item in any number depending upon the available quantity. The item selected will get delivered to the user. There is a delay of 2 seconds for the delivery of next product (incase of more number of same item selected). Notification is sent to the user's mobile number incase of low balance or insufficient fund.

### 4 . ADVANTAGES

- Fingerprint sensor offers high security as the fingerprint of each individual is unique.
- Avoids the need of a salesman.
- Do not need to carry cash in hand.
- This vending machine gives users a free choice to purchase products at any time.

### 5. DISADVANTAGES

- Power consumption is higher.
- Delivery using tray mechanism becomes practically difficult when it comes to large number of products.

- Purchasing of variety goods becomes not possible at a time.
- Cancellation of purchase is not available.
- This machine has no provision for bargaining. Therefore fixed prices are applied for the products.

[7] "AUTOMATIC PAPER VENDING MACHINE", Kamalanathan.P, Villupuram, Irshath Ahmed. R, Mohamed Aamir. M. Kalaiselvan. P, Associate Professor.

## 6. CONCLUSION

In today's secure world biometric safety is on the top. Unlike other techniques which make use of passwords and numbers, that are needed to be remembered, biometric techniques make use of human body parts like fingerprints or even iris of your eyes and as we know that these things are unique to all thus it makes biometric systems the most effective over others. And also as our society is becoming cashless i.e. handling money by digital networking and not by hand payment .Using this fingerprint technology on our vending machine it has helped to achieve a high security for the users. This does not need a separate person or a salesman to monitor or control, it is all done by the machine by selling and deduction from the account of the user and the interaction of the GSM module has helped the user to know whether it is low balance.

## 7. REFERENCE

[1] "Development of a GSM based Control System for Electrical Appliances, Oke A. O., Emuoyibofarhe J. O., Adetunji A. B.

[2] Swati R.Zope, Prof.Maruti Limkar, "RFID based Bill Generation and Payment through Mobile", International Journal of Computer Science and Network (IJCSN)

[3] ROBERT A. SOHLEGEL., Google Scholar, "Vending Machine".

[4] International journal of engineering sciences & research technology, "Design and implementation of fingerprint assist vending machine using microcontroller."

[5] "Real time embedded based drinking water vending machine" Sasikala, G., Kuldipsing Rajput, Sarfaraj Hussain and Aastha Shrivastava

[6] "Food vending machine for schools", PROJECT REFERENCE NO. : 37S0803, Subrahmanya Shetty , Chandrashekhar Moger , Shivananda l.C, Udaya G.