

Electromagnetic Punching Machine

Ankit Pawar¹, Arjun Pawar², Lalit Sillak³ Pritish Sonawane⁴ Amay Tipayle⁵

¹²³⁴Dept of Mechanical Engineering, JESITMR'S,Nashik

⁵Example: Professor, Dept. of Mechanical Engineering, JESITMR'S,Nashik

Abstract - Punching Machine is one of the principal machines in paper cutting industry & sheet metal industry. It is mainly used as the name indicates to cut strips. So we are going to make a machine for "UNCHING INDUSTRIES" and make it multipurpose & should be used to cut the card board, asbestos sheets, papers, foam, thin plastic sheets. The machine is simple to maintain, easy to operate. Hence we tried our hands on "automatic punching machine." Automatic punching machine is working on the principle of electromagnetic. This type of punching machine is used to punch basically card board, asbestos, sheets, papers, foam, and thin plastic sheets. Punching is depend on feed rate which done manually. The Greatest challenge faced by an engineer is to overcome the energy wasted due to friction in any mechanical process. In a conventional punching process, mechanical or hydraulic force is used to operate the punch which involves large amount of metal to metal contact in the drive system components, as well as inaccuracy in the control of the punching forces at the micro level. This paper introduces the basic construction of an electromagnetic assisted punching machine to carry out the punching operation. After successful fabrication, the set up was tested and the punching force produced was validated.

Key Words: Electromagnet, Friction, Punching, Automation

1.INTRODUCTION

Punching Is A Metal Forming Process That Uses A Punch Press To Force A Tool, Called A Punch, Through The Work piece To Create A Hole Via Shearing. The Punch Often Passes Through The Work Into A Die. A Scrap Slug From The Hole Is Deposited Into The Die In The Process. Depending On The Material Being Punched This Slug May Be Recycle And Reused Or Discarded. Punching Is The Cheapest Method For Creating Holes In A Sheet Metal For Medium To High Production Rates. In Forging Applications The Work Is Often Punched While Hot, And This Is Called Hot Punching. A Punch Is Often Made Of Hardened Steel Or Carbides. A Die Is Located On Opposite Side Of The Work Piece And Helps To Localize The Shearing Force For A Cleaner Edge. There Is A Small Amount Of Clearance Between The Punch and The Die To Prevent The Punch From Sticking On To The Die.

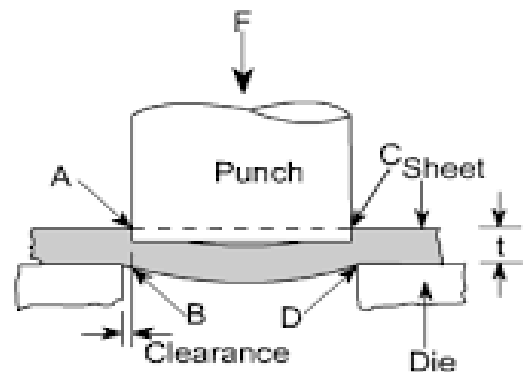

Fig -1: Punching Process

Punching Machines Are Classified According To The Following:-

- 1) Pneumatically Operated
- 2) Hydraulically Operated
- 3) Rack And Pinion Operated
- 4) Spring Operated

1.1 Objective

- To Reduce The Man Power.
- To Maintain The Accuracy.
- To Develop Automation Unit For The Punching So That Machine Can Easily Be Adopted In Today's Automated Plants.
- This Type Of Machine Provides Work Practically At Low Cost, Low Maintenance, Low Capital Investment In Less Space.
- To Perform The Most Rigid Operation With High Speed.

1.2 Problem Statement

The Statement Of Project Is "Design Of Electromagnetic Punching Machine" For The Punching Of Different Sizes Of Gaskets & Card Board As Per Requirements For Industry. The Punching Is The Major Operation Performed In Industry, And To Perform This Operation In Mass Number The Man Power Is Require Which Results In To High Cost Of Production, More Time Require To Complete The Operation, Affect The Accuracy Of Product So For Automation In System We Are Trying To Do A Work On New System In Punching.

2. Methodology

Methodology Used For Whole Processing Of Electromagnetic Punching Machine Is Given Below; This Methodology Gives Way About How Work Is To Be Carried Out In Systematic Way. It Is Standard Process Of Describing Process, How It Is Done In Simplest Manner.

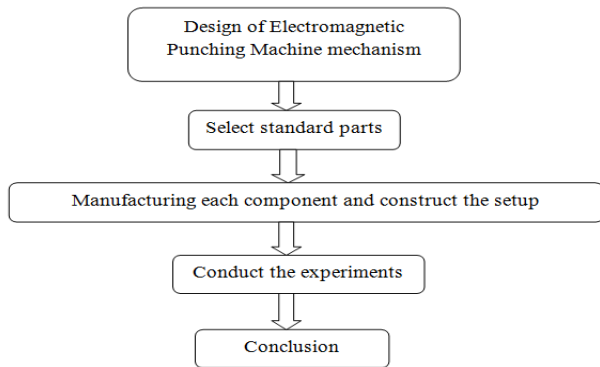

Fig -1: Flow of the system

The Punching Machine Consists Of A Punching Tool, Die, Push Rods, Transverse Beam, Return Springs And An External Support Structure. A Switch Is Connected Between The Dc Power Supply And The Windings Of An Electromagnet. When The Setup Is Connected To A 230 Volt, 2amps Dc Supply, The Coils Are Supplied With Electricity And The Magnetic Field Is Developed Around The Coil. The Electromagnetic Core Which Is Within The Magnetic Field Gets Magnetized And In Turn It Exerts A Force Proportional To The Electricity And Attracts The Transverse Beam. The Mild Steel Plate Is Connected To The Ends Of A Punching Tool Through Two Push Rods. Thus When The Plate Moves Towards The Core, The Push Rods Transmit The Motion Onto The Punching Tool With The Same Force Developed By The Electromagnet. The Punching Tool Moves Toward The Die Block And Punches The Surface Of The Work Piece.

The Tool And Work Piece Are Then Separated By Means Of Two Return Springs. The Springs Are Initially Compressed During The Forward Stroke. When The Electric Supply Is Cut Off, The Magnetic Field Ceases To Exist And After The Electromagnet Loses Its Magnetization, The Spring Retracts. As The Main Problem Founded Which Is Regard With Quality And Times Consume To Perform The Desire Operation So To Develop The Automation Machine Is Best Solution To Overcome The Same Problem. These Machines Will Give Fully Automation Production With help of Electromagnet. The Below Flow Chart Shows The Sequential Operation/Steps That Will Be Performed During The Project Process.

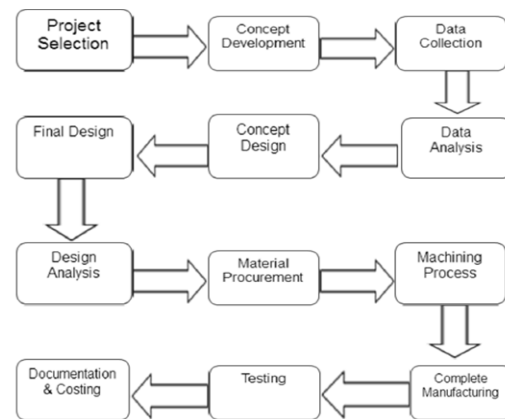

Fig -1.1: Methodology

2.1 Construction And Working:-

The Punching Machine Consists Of A Punching Tool, Die, Push Rod, Supporting Vertical Pin, Springs, Vertical Rod, Lock Pins And An External Support Structure. Control Panel Consist With Volt Meter, Indicator, Push Button. Switch Is Connected Between Power Supply->Control Panel->Magnetic Windings. This Setup Is Connected To Single Phase, 230 Volt Supply Which When Get „On“ The Power Is Supply To The Electromagnet And The Magnetic Field Is Get Generated Due To This Magnetic Field The Mild Steel Plate On The Electromagnet Is Get Attracted Towards The Electromagnet And At The Same Time The Push Rod Is Also Get In Downward Direction Which Creates The Punch On Material When The Electric Supply Is Cut Off, The Magnetic Field Stop To Exist And After The Electromagnet Loses Its Magnetization, The Spring Retracts, Moving The Punching Tool Away From The Work Piece And The Cycle Is Complete.

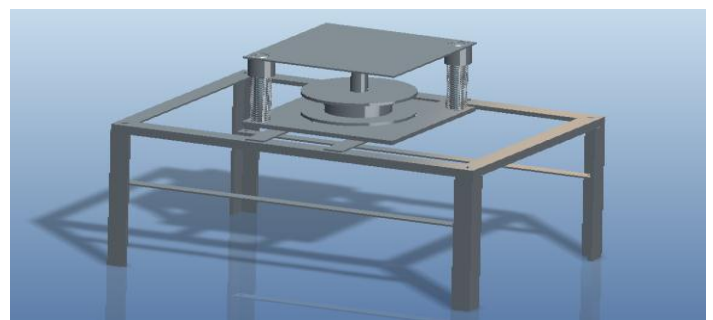

Fig:- 2.1 Working Of Electromagnetic Punching Machine

2.2 Mechanical Design

In Mechanical Design The Components Are Listed Down And Stored On The Basis Of Their Procurement, Design In Two Categories Namely.

1. Designed Parts
2. Parts To Be Purchased

Mechanical Design Phase is very Important from the view of designer as whole success of project depends on the correct design analysis of The problem.. He Should Identify All Internal And External Forces Acting On Machine Parts.

These Forces May Be Classified As,

- A) Dead Weight Forces
- B) Friction Forces
- C) Inertia Forces
- D) Centrifugal Forces
- E) Forces Generated During Power Transmission Etc.

Designer Should Estimate These Forces Very Accurately By Using Design Equations. If He Does Not Have Sufficient Information To Estimate Them He Should Make Certain Practical Assumptions Based On Similar Conditions Which Will Almost Satisfy The Functional Needs. Assumptions Must Always Be On The Safer Side. Selection Of Factors Of Safety To Find Working Or Design Stress Is Another Important Step In Design Of Working Dimensions Of Machine Elements. The Correction In The Theoretical Stress Values Are To Be Made According In The Kind Of Loads, Shape Of Parts & Service Requirements Selection Of Material Should Be Made According To The Condition Of Loading Shapes Of Products Environment Conditions & Desirable Properties Of Material Provision Should Be Made To Minimize Nearly Adopting Proper Lubrications Method.

2.3 Application

- Punching Of Foam For Packaging Accessories.
- Punching Card Board From 1mm To 5mm.
- It Can Be Used To Punching The Asbestos Sheet For Gasket Sheet.
- It Is Used To Punching A Plastic Sheets And Paper.

3. Future Scope

1. The Flux Of Electromagnet Can Be Increased By Increasing The Size Of The Same And By Increasing The Coil Turns. So This Modification Enables This Machine To Punch Much Thicker Materials.
2. By Changing Design Of Parts And By Using Higher Capacity Electromagnet We Can Use This Machine For Cutting Harder Materials.
3. This Machine May Form Simple Solution For Punching In The Future.
4. This Machine Also Can Be Controlled By Computer Programs.
5. Can Be Used For Gasket Punching And Thin Metal Sheet Working Operations In Future.

4. CONCLUSIONS

While Concluding This Report, We Feel Quite Fulfill In Having Completed The Project Assignment Well On Time, We Had Enormous Practical Experience On Fulfillment Of The Manufacturing Schedules Of The Working Project Model. We Are Therefore, Happy To State That The In Calculation Of Mechanical Aptitude Proved To Be A Very Useful Purpose. Although the Design Criteria Imposed Challenging Problems Which, However Were Overcome By Us Due To Availability Of Good Reference Books. The Selection Of Choice Raw Materials Helped Us In Machining Of The Various Components To Very Close Tolerance And Thereby Minimizing The Level Of Wear And Tear. Needless To Emphasis Here That We Had Lift No Stone Unturned In Our Potential Efforts During Machining, Fabrication And Assembly Work Of The Project Model To Our Entire Satisfaction.

ACKNOWLEDGEMENT

We would like to express our hearty thanks to all those who helped us the completion of the Project on 'Automatic Washing of Two Wheeler'. Our special thanks of gratitude of our teacher Prof. A. R. Tipayle, Mechanical Engineering Department, JESITMR'S College of Engineering, Nashik. for his guidance and continuous motivation. As well as our principal Dr. M.V. Bhatkar. Who gave us the golden opportunity to do this wonderful project We gratefully acknowledge the help provided by his on many occasions, for improvement of this project with great interest. Their valuable suggestions were very helpful. Last but not the least, I would like to thanks to our All Mechanical Department Staff Member's, Family and Friends who helped with the ever daunting task of gathering information for the project Report.

REFERENCES

- [1] Deshmukh S.R.,Gharate H.B" Electromagnetic Punching Machine" International Journal Of Modern Trends In Engineering And Research Volume 2, Issue 2,July 2015 E-Issn No:-2349-9745.
- [2]Satalkar A.B.,Shah M.R.,Thoke A.M." Design And Fabrication Of Electromagnetic Punching Machine For Industrial Application" International Journal of Emerging Technology And Advanced Engineering"Volume 5,Issue 4, April 2015 Issn 2250-2459, Iso 9001:2008 Certified Journal.
- [3] International Journal Of Modern Engineering Research Ijmer | Issn: 2249-6645 | | Vol. 5 | Iss. 7 | July 2015 | 26 |
- [4]Shyam Sundar,Mohmmad Raseem, Tarun Veeraraghavan Amai" Novel Design And Model Of Punching Machine Driven By Electromagnetic Actuator" International Journal On Manufacturing And Material Science Volume 01,Issue 02,November 2014 Doi: 01.Ijmms.01.02.
- [5]6th International Conference On High Speed Forming - 2014 Volume 01,Issue 2014