

Automatic Self Cleaning Solar Panel

Athira Sivan¹, Athira Sivan², Lakshmi Priya G S³ and Sera Mathew⁴

^{1,2,3}Student, Dept. Of Electrical and Electronics, Mar Athanasius College of Engineering , Kerala, India

⁴Professor, Dept. Of Electrical and Electronics, Mar Athanasius College of Engineering , Kerala, India

Abstract - An Some of the best places to collect solar energy are also some of the dustiest on Earth. Dust from pollution and traffic that fall on the solar panel surface prevents the sunlight from reaching the solar cells. The efficiency of solar panel gets affected in the presence of dust particles. While many factors affect how much electricity your solar panels will produce, dusty solar panels can be one of the biggest, and easiest to fix. Experts have agreed that dusty solar panels do not produce as much power as clean panels. The power output of the panel degrades up to 50% due to the dust accumulation. A solar panel cleaning system is proposed in order to make a solar panel operate at the best power generation state, while the solar panel is used in dusty environment. This project consists of a LDR sensor, wiper unit and sprayer. The LDR sensor is used to detect whether it is a day or night. Depending on the solar output the presence of dust on the surface of solar is detected. If the dust is detected the wiper starts to work on the surface along with the water sprayer.

- Light Dependent resister
- Motor
- Relay
- LCD Display

Key Words: LDR, Sensor, Sprayer, Wiper

1. INTRODUCTION

Photovoltaic array installations are becoming more prevalent around the world. Each of these solar parks has an expected lifetime of 20-25 years, and it is vital to maximize the power generating potential during daily service. The energy produced by solar photovoltaic modules is related with the sun's available irradiance and spectral content, as well as other factors like environmental, climatic, component performance and inherent system. The accumulation of dust particles and debris on the surface of photovoltaic (PV) panels negatively affects the performance. Cleaning dirty panels with commercial detergents can be time consuming, costly, hazardous to be environment, or even corrode the solar panel frame. Ideally solar panels should be cleaned every few weeks to maintain peak efficiency, which is especially hard to do for large solar panel arrays. There is a need for an automated cleaning solution to this problem which can service large ground based solar array up to an operating park of 22,000 panels (20,000 Square meters).

2. BLOCK DIAGRAM REPRESENTATION

The block diagram mainly consists of

- AVR Micro-controller
- Solar panel

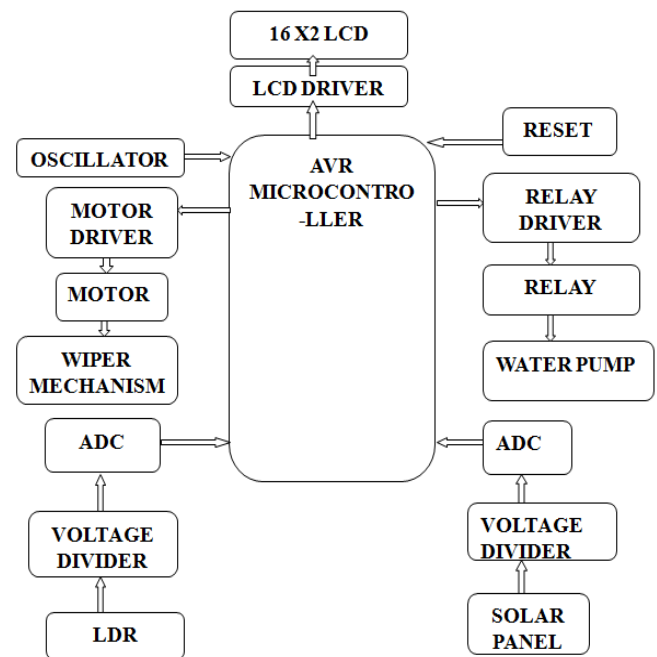

Fig -1: Block Diagram

The figure-1 shows the block diagram of Automatic Self Cleaning Solar Panel. It contains AVR Microcontroller, Solar Panel, Light Dependent Resistor, Relay, Motor, LCD Display, Wiper. The major heart of this project is AVR microcontroller. In this system, we use an LDR, which identifies the present condition of atmosphere that is day or night. The output from LDR and solar panel is fed to the Atmega 32 microcontroller through voltage divider and analog to digital converter. Voltage divider is a passive linear circuit that produces an output voltage that is a fraction of its input voltage and ADC converts an input analog voltage to a digital number proportional to the magnitude of the voltage. This project includes a washing system. Where water was provided by water storage tanks, and a dedicated water pump included to convey the water at suitable pressure. This system also includes a wiper mechanism with suitably shaped wipers, whose action covers the surface of the panels during sweep cycle of the wiper. In wiper system, a motor motivates the wiper to move across the panel. The motor is powered by electricity from power storage device, which itself is charged by the electricity generated by panel during daytime.

3. OPERATION

Bridge rectifier is an Alternating Current (AC) to Direct Current (DC) converter that rectifies mains AC input to DC output. The bridge rectifier circuit diagram consists of various stages of devices like transformer, Diode Bridge, filtering and regulators. Bridge Rectifiers are widely used in power supplies that provide necessary DC voltage for the electronic components or devices.

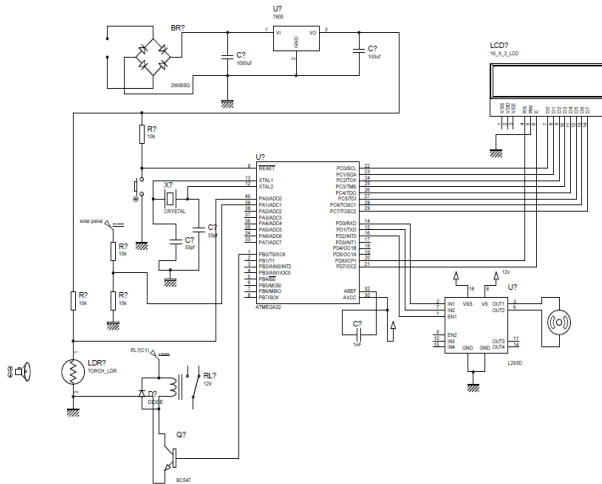

Fig -2: Circuit diagram of the proposed prototype.

Figure-2 shows that circuit diagram of automatic self cleaning solar panel. The circuit diagram consist of ATMEGA 32 microcontroller, LDR, Solar panel, LCD, Motor driver circuit, AVR is a 40 pin IC. Here to interface LCD with AVR, an 8 bit data bus is required. 16X2 LCD can interface with AVR microcontroller by using two modes, 4-bit mode or 8-bit mode. In this circuit we will use 8-bit mode for interfacing. In 8-bit mode we send command to LCD by using eight data lines (D0-D7) for sending command and data. These data lines can be connected to any port of Atmega32. LDR and Solar Panel is connected at port A, the ADC is configured in free running mode and is left adjusted so only ADCH register is read. The output is at Port C where 8 leads are connected. If the light falling on LDR is more no. of led glowing are less and vice-versa. The value of ADCH is show on the LCD. L293 is a most popular and less expensive built-in H-bridge in a small integrated circuit used for low current motors. H-bridge is a motor driving unit used to control the direction of two motors at a time either clockwise or anticlockwise direction. It is a 16 pin IC in which pins out1 and out2 connected to the motor. Connect the IN1, IN2, and EN1 pins of L293 with PD0, PD1, and PD2 pins of Atmega32. Connect the VS and VS pins 12V and GND pins of L293 with ground.

4. EXPERIMENTAL SETUPS AND RESULT

The automatic cleaning system is an innovative technology used to clean the accumulated dust on the solar panel during day time. In the system, we use an LDR, which identifies the present condition of atmosphere that is day or night. The

output from LDR and solar panel is fed to the Atmega 32 microcontroller. In this system, we have programmed, the LDR output as 50v, for day condition, during which the light intensity is very high. For a clean and dust free solar panel will be 150mv. Now the wiper remains stationary. When LDR output exceeds 50v and the solar panel output decreases to any value below 150mv, it indicates the presents of dust. Now the stationary wiper will start to work, cleaning the solar panel. The wiper will go back and forth trice. The swiping mechanism improves the efficiency of solar panel. The wiper action is controlled using a dc motor. A 12v battery is used for the proper working of this dc motor. Another feature of the this system is that, this 12v battery is charged using solar panel. If the voltage of solar panel does not increases above 150mv, after cleaning the panel thrice, then a message Contact Technician will be displayed on the LCD screen. Figure-3 shows the experimental setup.

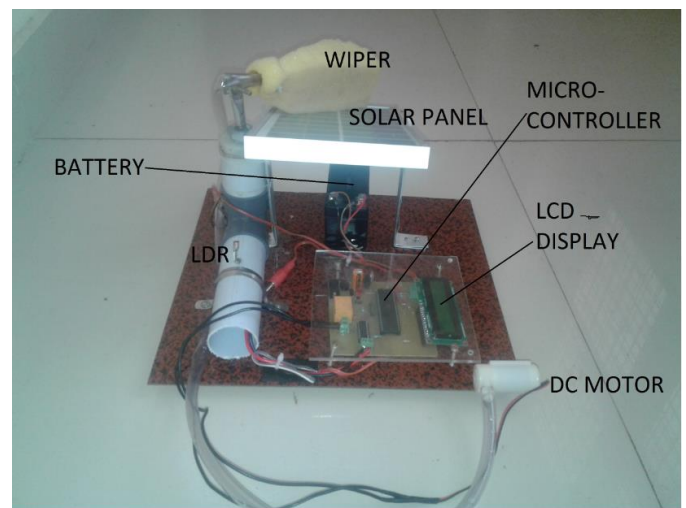

Fig -3: Experimental Setup of Proposed prototype

5. CONCLUSIONS

This project highlights the effect of dust, dirt, pollen, seasalt, and bird droppings on the PV systems efficiency. However, the development of the cleaning system can solve those problems. This development is divided into two parts: hardware(stability and cleaning mechanism) and the software. The software development for the cleaner system has been done in the project. The cleaning time has been reduced by setting a path for the robot on the surface of the PV panels, instead of using the forward and backward movement of the wiper. From this project learned about the designing programs using Arduino software. Also leaned how to lead manage a project in the future. The weakness of this project were the limited time.

6. REFERENCES

- [1] M. Mani and R. Pilla, Impact of dust on solar photovoltaic performance: Research status, challenges and recommendations, *Renewable Sustainable Energy Rev.*, vol.14, pp.31243131, 2010. DOI:10.1088/j.rser.2010.07.065.
- [2] M Anderson, A Grandy, J Hasti, A Sweezey, R Rankey, C Mavroidis and Y.P Markopoulis, Robotic Device For Cleaning Photovoltaic Panel Arrays, in: *Mobile Robotics*, pp. 367-377, 2009. DOI: 10.1142/9789814291279-0047.
- [3] K.A Moharram, M.S Abd, H.A Kandil and H EI- Sherif, Influence of cleaning using water and surfactants on the performance of photovoltaic panels, *Energy Convers.Manage.*, vol.68, pp.266272, 2013 DOI:10.1016/j.enconman. 2013.01.022.
- [4] Kutaiba Sabah and Sabah Nimma Faraj, "Self cleaning solar panels to avoid the effect of accumulated dust on solar panels transmittance," *International Journal of Science and Research (IJSR)*, India Online ISSN:2319-7064.