

MIMO-LTE System for High Speed Communication

Varsha Dewangan¹, Sandeep Bhad², Dr. Pankaj Mishra ³

¹MTEch Scholar, Digital Electronics, varshadew07@gmail.com

²Asst. Professor, sandeepbhad@gmail.com

³Asso. Professor, pmishra1974@yahoo.co.in

¹²³ Dept. of Electronics and Telecommunication Engineering, Rungta College of Engineering and Technology, Bhilai, India

Abstract - This article proposal targets at estimating 3GPP LTE, the representatives of the 4G wireless system. LTE is recent high-speed wireless communication technique which promises increased data rates, greater bandwidth, security and more productive use of the wireless spectrum. An intuitive way to enhance the total power at the transmitter and receiver side is to use diversity. Diversity based approach on beam forming uses multi-transceiver RF systems which potentially increases the received signal power and allow for higher data rates.

The crux of this proposal is an LTE MIMO system. The multi-antenna system (MIMO) technique is used in the LTE standard for performance parameters including higher radio access data rates, enhanced system capacity, significant boost in spectral efficiency, multi-antenna support, and seamless incorporation with the existing mobile communication systems. This proposal promises good quality signal with high data rates.

Key Words: 3GPP, LTE, MIMO, UMTS, HSDPA.

1. INTRODUCTION

The growth in data intensive mobile services and applications have led to the expansion of the next generation high-speed wireless standards to provide the data rates and network capacity necessary to support worldwide delivery of rich multimedia applications. In 1997, the goals declared by the ITU IMT-2000 (International Telecommunications Union International Mobile Telecommunication) were implemented. Various wireless standards such as UMTS, HSDPA, HSUPA, HSPA + (MIMO) were developed. The HSPA+ standard can reach 84Mbps rates and the use of an even higher modulation scheme (64QAM).

2. MULTI ANTENNA SYSTEM

Multi-antenna system uses multiple Tx_N antenna/ multiple Rx_N antenna. By using this system, it is viable to build high-speed wireless communication offering advanced data rates and small error rate. Multi-antenna systems are SISO, SIMO, MISO and MIMO systems [10-11, 17].

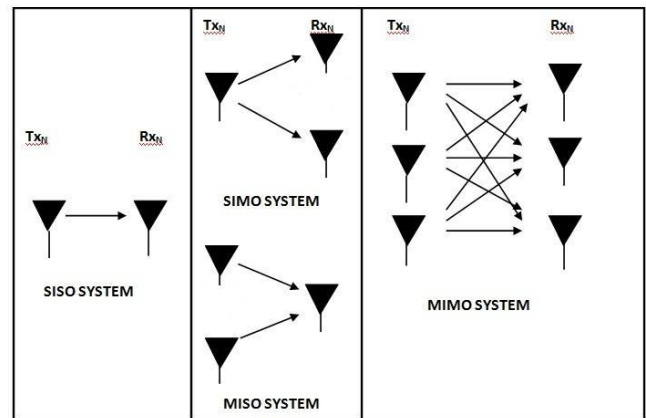

Fig-1: Multi-antenna Systems (SISO, SIMO, MISO, MIMO).

2.1 SISO (Conventional Radio System)

Conventional Radio transmission systems use single antenna for transmission and one antenna for reception [1]. In MIMO diction, the system is called as Single Input, Single Output (SISO) (Fig.1) system. Channel capacity is the maximal capacity of transmission that can be achieved on a channel given any combination of any coding scheme, transmission or decoding scheme. The channel capacity C of this system is given by:

$$C_{SISO} = B * \log_2(1 + \frac{S}{N}) \text{ bit / sec} \quad (1)$$

Where C is the capacity, B (in Hz) is the bandwidth of the channel, S (in Watt) is the output signal power, and N (in Watt) is the output noise power. Implementation of SISO is comparatively simple and cheap. It is used in TV broadcast, radio, personal wireless technologies such as Wi-Fi and Bluetooth.

2.2 SIMO

In MIMO term, a system in which the number of Rx_N antennas is more than Tx_N antennas[2] is termed as Single Input Multiple Output (SIMO) system, also known as Receive diversity (Fig. 1) The simplest case consists of Tx₁-Rx₂ antenna. The multiple receive antennas can help us get a

stronger signal through diversity. The SIMO channel capacity is given by,

$$C_{SIMO} = B * \log_2(1 + \frac{nS}{N}) \text{ bit / sec} \quad (2)$$

Where C is known as capacity, B is known as bandwidth, S/N is known as the signal to noise ratio, n is the number of antennas used at the receiver side. Implementation is very simple. The signal-to-noise ratio can be improved by employing the suitable approach in the receiver.

In Switched Diversity or Selection Diversity Technique, the receiver chooses the best antenna to receive a stronger signal or can merge signals from all antennas in such a way that maximizes SNR known as Maximum Ratio Combining (MRC) Technique. MRC is a mostly good multi-antenna system technique when, in a fading channel, signals exhibit equal strengths.

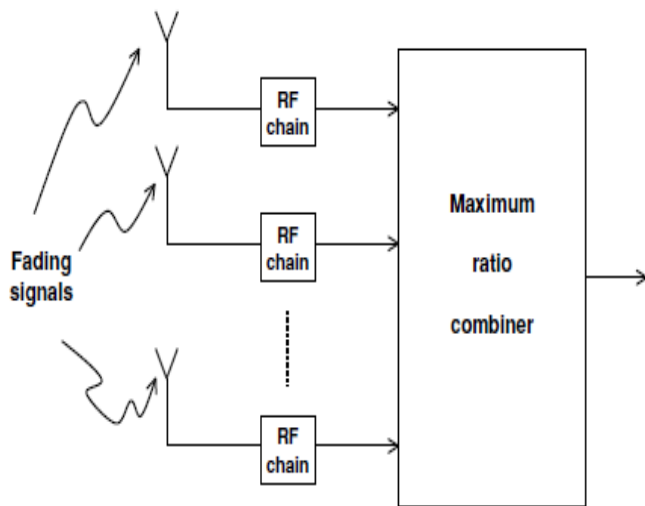

Fig-2: MRC Technique

2.3 MISO

A system in which the number of Tx_N antennas is more than Rx_N antennas, is named Multiple Input Single Output (MISO) system, also called Transmit diversity (Fig.1). The simplest scenario uses Tx₂-Rx₁ antenna (MISO, 2x1).

The redundancy coding is displaced from the mobile UE to the base station, so this method is advantageous, easier and cheaper to implement these technologies. Alamouti STC (Space Time Coding), a technique employed at the transmitter with two antennas. STC are used in order to produce a redundant signal. It allows the message to be transmitted by transmitting antennas at distinct times consecutively i.e. the replica of the signal sent through different antenna at different time. This type of delayed transmission is called Delayed Diversity.

Fig 3 depicted the combination of spatial and temporal signals in Space-time codes. Signal replica is added to create the Alamouti space-time block code later. Multiplexing of the signals s₁ and s₂ are done in two data chains. Space-time codes enhance the conduct and make spatial diversity accessible. Space Frequency Coding is a frequency domain signal processing. The MISO capacity is given by,

$$C_{MISO} = B * \log_2(1 + \frac{nS}{N}) \text{ bit / sec} \quad (3)$$

Where, n = number of transmitting antenna in MISO systems, C= System Capacity, B= Bandwidth of the system and S/N= Signal to noise ratio.

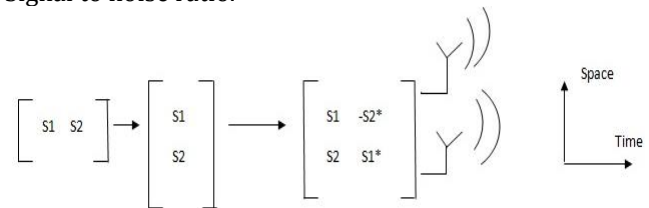

Fig-3: Alamouti Coding

2.4 MIMO

Using additional antennas at the transmitter and/or the receiver is an efficient way of increasing the received power, improvement in capacity and Bit Error Rates (BERs). This represents a class of multi-antenna system referred to as Multiple Input Multiple Output (MIMO) System. Figure 1 depicted a MIMO system which mostly consists of Tx_N-Rx_N antennas where N denotes number of antennas.

Among various MIMO techniques, Spatial Multiplexing introduces a multi-antenna methodology that achieves a linear capacity growth with the number of antennas used. The capacity is defined as the maximizing of the mutual information between the input and output given a power constraint P on the total transmission power of the input, that is $Tr(K_C) \leq P$, where $Tr(K_C)$ is the trace of a matrix K_C . K_C is the covariance of the input C. In other words,

$$C = \max_{Tr(K_C) \leq P} \log_2(\det[I_M + (\frac{\gamma}{N})H^H \cdot K_C \cdot H]) \text{ bits / sHz} \quad (4)$$

The unit bits/(sHz) represents the fact that for a bandwidth of W, the maximum possible rate for reliable communication is CW bits/s.

3. SPATIAL MULTIPLEXING GAIN AND ITS TRADE-OFF WITH DIVERSITY

By using spatial multiplexing, in general one can transmit up to $\min \{T_{X_N}, R_{X_N}\}$ symbols per time slot, where

T_{X_N} : Number of transmit antenna

R_{X_N} : Number of receive antennas.

If $T_{X_N} \geq R_{X_N}$, one can send R_{X_N} symbols and achieve a diversity gain of $T_{X_N} - R_{X_N} + 1$. Note for $T_{X_N} = R_{X_N}$, the diversity gain will be one. On the other hand, the maximum spatial diversity while transmitting only one symbol per time slot is $T_{X_N} * R_{X_N}$. Therefore, the advantage of a MIMO channel can be utilized in two ways, by increasing the diversity and the number of transmitted symbols of the system. For the case in which transmit antenna is more than one, $T_{X_N} \geq R_{X_N} > 1$, there is a theoretical trade-off between the number of transmit symbols and the diversity of the system (Fig 4). The capacity of a MIMO channel increases by raising the SNR.

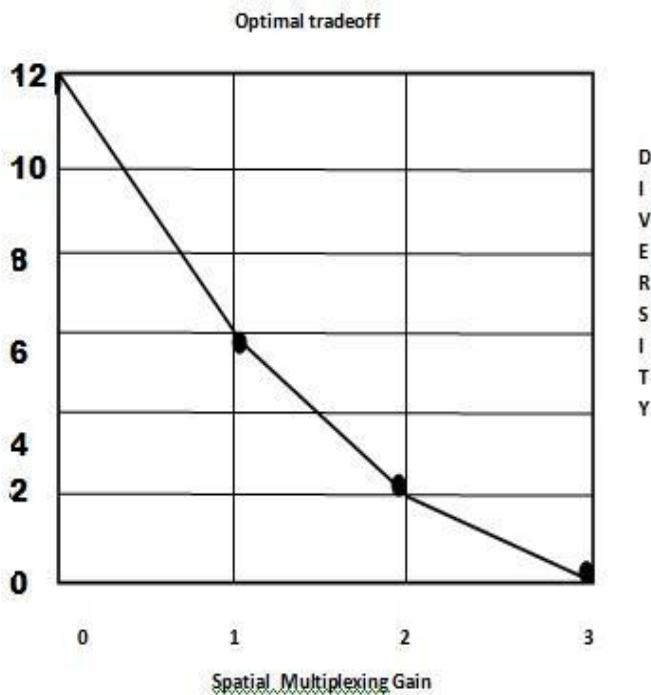

Fig-4: Optimal trade-off between Spatial Multiplexing Gain (an indication of rate) and Diversity[4]

4. LONG TERM EVOLUTION (LTE)

LTE fulfill the aim of achieving global broadband mobile communications. The objectives include improved radio access data rates, improved system capacity along with spectral efficiency, reduced operating costs, flexible bandwidth, low latency, multi-antenna support.

Table-1: Summarizes the peak data rates of various wireless technologies.

Technology	Theoretical peak data rate (at low mobility)
GSM	9.6 Kbps
IS-95	14.4 Kbps
GPRS	171.2 Kbps
EDGE	473 Kbps
CDMA-2000(1xRTT)	307 Kbps
WCDMA(UMTS)	1.92 Mbps
HSDPA(Rel 5)	14 Mbps
CDMA-2000(1x-EV-DO)	3.1 Mbps
HSPA+(Rel 6)	84 Mbps
WiMAX(802.16e)	26 Mbps
LTE(Rel 8)	300 Mbps
WiMAX(802.16m)	303 Mbps
LTE-Advanced(Rel10)	1 Gbps

4.1 LTE (Releases 8 & 9) and LTE-Advanced (Release 10)

LTE standard (3GPP version 8) was released in December 2008. Release 9 came in December 2009[3]. It included features such as Multimedia Broadcast/Multicast Services support, location services, and provisioning for base stations that support multiple standards. LTE-Advanced (released in December 2010) is a transformation of the original LTE standard. It includes technologies such as carrier aggregation, enhanced downlink MIMO, uplink MIMO, and relays[3]. Table 1.summarizes the peak data rates of various wireless technologies.

4.2 LTE-MIMO

Incorporation of many multi-antenna systems techniques results in achieving high maximum data rates standards like the LTE and its advanced standards. MIMO algorithms exploits two main multi-antenna techniques i.e. Transmit Diversity such as SFBC and Spatial Multiplexing with or without delay diversity coding. On different antennas, the relationship between T_{X_N} and R_{X_N} resource elements is expressed by a system of linear equations at each subcarrier. In this system, the multiplication of the vector of transmitted resource elements on transmitting antennas by the MIMO channel matrix results in the vector of received resource elements on receive antennas. As indicated by the MIMO system of equations, so as to recover the best estimate of the transmitted resource element at a given subcarrier, we need not only the vector of received resource elements but also the channel response channel state information connecting each pair of transmitting and receive antennas.

5.SURVEY RESULT

It has been surveyed that the capacity and data rates can be increased by using Multi-antenna systems such as SIMO, MISO, MIMO in spite of SISO system.

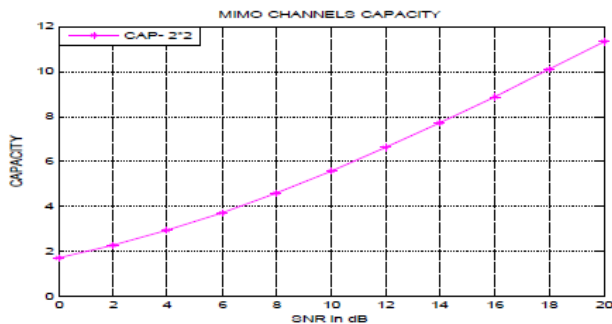

Figure 5 depicts the channel capacity of MIMO with two transmit antennas and two Receive antennas assuming a Rayleigh fading model. It can be seen that at SNR of 20 dB, it is possible to achieve capacity of the order of 11 bits/sec/Hz

6. CONCLUSION

This paper presents that increase in systems data rates & performance is achieved by proper system design of MIMO system. The capacity hikes linearly by using MIMO system at high SNR, i.e. as T_{X_N} and/or R_{X_N} of the MIMO system increases their capacity increases. We have presented the Shannon capacity formula. Different multi-antenna systems are studied thoroughly.

REFERENCES

- [1] 1MA142_0e_introduction_to_MIMO
- [2] <http://www.conniq.com/WiMAX/mimo-01.htm>
- [3] Understanding LTE with MATLAB: From Mathematical Modeling to Simulation and Prototyping, First Edition by Houman Zarrinkoub.
- [4] SPACE-TIME CODING THEORY AND PRACTICE HAMID JAFARKHANI University of California, Irvine 1989.
- [5] Multiple-Antenna Systems Jan Mietzner (janm@ece.ubc.ca, Room: Kaiser 4110)
- [6] Yamini Devlal, Mrs. Meenakshi Awasthi. Capacity Analysis of MIMO Technology, International Journal Of Engineering And Computer Science ISSN:2319-7242 Volume 4 Issue 1 January 2015, Page No. 9819-9824.
- [7] Arif Khan, Rein Vesilo. A Tutorial on SISO and MIMO Channel Capacities, publication/265811248
- [8] May Ch. Giri, Anwasha Sahoo, J. R. Swain, P. Kumar, A. Nayak, P. Debogswami. Capacity & Performance Comparison of SISO and MIMO System for Next Generation Network (NGN), 6 International Journal of Advanced Research in Computer Engineering & Technology (IJARCET) Volume 3 Issue 9, September 2014

- [9] Kritika Sengar ,Nishu Rani, Ankita Singhal, Dolly Sharma, Seema Verma, Tanya Singh. Study and Capacity Evaluation of SISO, MISO and MIMO RF Wireless Communication Systems, 1 International Journal of Engineering Trends and Technology (IJETT) – Volume 9 Number 9 - Mar 2014.
- [10] S.D. Bhad, A.S. Hiwale, A.A. Ghatol, Bhad. Performance Analysis Of Space Time Trellis Code with receive Antenna selection. In: IEEE fourth International Conference on Wireless Comm. and Sensor Networks, WCSN 2008, pp. 148–152 (December 2008). DOI: 10.1109/WCSN.2008.4772700
- [11] Sandeep Bhad and A.S. Hiwale. Performance Analysis of MIMO- Space-Time Trellis Code System over Fading Channels. Springer Berlin Heidelberg on Advances in Computing, Communication and Control, 2011.
- [12] Modern Wireless Communication by Simon Haykin, Michael Moher.
- [13] Digital Communications by John G. Proakis.
- [14] MIMO Wireless Communication, 1st Edition, MIMO Wireless Communications, by Ezio Biglieri, Robert Calderbank, Anthony Constantinides, Andrea Goldsmith , Arogyaswami Paulraj, H. Vincent Poor , Cambridge university press.
- [15] Wireless Communication , by Andrea Goldsmith ,Cambridge university press
- [16] G. J Foschini and M. J. Gans " On limits of wireless communication signal fading environment when using multiple antennas " Wireless Personal Communications vol. 6 pp. 311-335 1998.
- [17] A. S. Hiwale A. A. Ghatol "A reduced complexity MIMO system with antenna selection for high-data rate wireless communications" Journal of Scientific and Industrial Research NISCAIR New Delhi vol. 7 pp. 498-504 July 2007.