

## A Laser Shaft Alignment by IPS- PSD's for Rotary machine

Sitaram Garg<sup>1</sup>, Sanjeev Kumar<sup>2</sup>, Rahul Deshpande<sup>3</sup>, A.K. Sharma<sup>4</sup>

<sup>1</sup>Machine Design, Department of Mechanical Engineering, C.B.S. Group of Institutions Jhajjar Haryana India

<sup>2</sup>Assistant Professor, Department of Mechanical Engineering, C.B.S. Group of Institutions Jhajjar Haryana India

<sup>3</sup>Manager, Department of Reliability and Condition Monitoring, SKF India Ltd Pune Maharashtra India

<sup>4</sup>A.K. Sharma, Assistant Professor, Department of Mechanical Engineering MITS College of Engg. Gwalior M.P.

India

\*\*\*

### Abstract

Laser-optical alignment of shafts in rotating machinery is simple and more accurate than conventional mechanical methods and can result in reduced power consumption and increased mean time between failures. For a typical steel plant running 500 small to medium-to-medium-sized rotating machines consuming 15 MW of power, total savings can amount to dollar 0.5 million / year as a result of a supported laser shaft alignment methods. Shaft alignment is an important technique during installation and maintenance of a rotating machine. A high precision laser alignment system has been designed with PSDs (Position Sensing Detector) and IPS (Inductive Proximity Sensor) to change tradition manual way of shaft alignment and to make the measurement easier and more accurate. The system is comprised of two small measuring unit (Laser transmitter and detector) and PDA (Personal digital assistant) with measurement software. The laser alignment system with PSD has been successful for designing and implements actual shaft alignment. SKF offers precise laser shaft alignment tools TKSA 11 and TKSA 20 for proper alignment of shafts and reduced troubleshooting issues. It can measure errors and display resolution less than 2% / 10  $\mu\text{m}$  (0.4 mils).

**Key words:** Rotating machine, Shaft alignment, Laser alignment, Position sensing detector (PSD), Laser micro - displacement measurement, Transmitter and Detector, Alignment Software SKF TKSA 11, Display unit SKF TKSA 20

### INTRODUCTION

Laser shaft alignment is a way of measuring misalignment between two or more shafts. Laser alignment will provide this long term benefit. Improved machine reliability and productivity, reduced machine repair costs, reduced labor costs, reduced power consumption of machinery, minimization of machine installation and repair time, allow verification of machine performance throughout the machine life. Perfect alignment of machinery shafts is crucial to prevent premature bearing failures, Shaft fatigue, Sealing problems and vibrations. It further reduces the risk of over-heating and excessive energy consumption, reduced unwanted breakdowns and improves down -time. Precise alignment occurs when the centerlines of rotation of two shaft essentially collinear with each other. Machine joined by coupling would generate

vibration when running because of shaft misalignment and the vibration affects the using life of machine and damages the parts. As we know almost 50% of the rotating machinery fault is caused by the shaft misalignment. So shaft alignment is an important process in power machinery assembly. The degree to which two machines are misaligned can be determined by examine the amount of offset and angularity that exists between them. Offset is the distance between the two rotational centerlines, and angularity is the angle between the centerline created by the misalignment of the two centerlines. The design and develop of a laser shaft alignment instrument based on the two dimensional PSD (Mu Li\* Wang Xinwei, 2012). The traditional precise shaft alignment method is dial indicator alignment (Piotrowski, 1995), and the two most popular methods are the rim and face method and the reverse indicator method. With the traditional technique, the measurement results must be graphed out manually and the calculations must yield the corrections required. With the laser alignment system all these are done automatically. Real time management values are displayed as the machine moves. The laser alignment system cuts the measurement time at each coupling by 50% compared to the previous method of taking 16-point rim and face dial readings (Perry, 1998). The improved accuracy of the laser also minimized the number of subsequent bearing alignment corrections required. The laser alignment system has been adopted for more and more precise shaft alignments, such as rotor system (Brommundt and Kramer, 2005), vibration (Lee, 2004), cooling tower fans (Luedeking, 2003), gas turbine (Luedeking, 2005), Link coupling (Pan et al., 1998), turbine driven feed water pump (Patry, 2001), etc. The single PSD laser alignment system designed by us has been applied in actual shaft alignment (Jiao et al., 2006). Dual PSDs method is based on the single PSD laser alignment, and has evidently improved the system measurement accuracy through some modification in the light road, circuits, and software. The advanced Laser technology is the key technology in measuring and adjusting shaft misalignment. The alignment purpose can be realize by adjusting shaft position according to the calculate result.

### MAIN METHODS AND TECHNIQUES

#### Laser alignment system:

The measurement principle of laser alignment is based on the dual indicator method. Alignment while dial indicator is an

accurate method provided these potential problem that can adversely affect readings are dealt with correctly (Studenberg, 2002; Vibrating Inc. 2002), (1)Indicator bar sag, (2) indicator hysteresis, (3) Low resolution, (4) reading errors, (5) role in mechanical linkage, (6) components the indicator touches magnetized by an exciter, (7) Shaft axial Play. Instead of steel bars with dials, it uses laser beam. Unlike steel bars, the laser beams do not have the disadvantage of sagging. In addition, PSD provides a high resolution and PSD signal processing circuit calculate the readout of laser system, so it eliminates human errors.

All of that contribute to high degree of accuracy. The schematic overview of the laser alignment system is given in Fig.1.



Fig.1 Schematic overview of the laser alignment system

**Design with dual PSDs:**

In the optics design, compared with the single PSD laser alignment system, the dual PSDs laser alignment system adds a prism between the laser transmitter and the detector. As Fig. 2 shows, the 90° alignment ring separates the incidence laser light to two beams. And beam finally projected to the PSD surface. From the feature of PSD (Perry, 2001), we know the position of the incidence light spot on each PSD.



Fig.2 Structure of the laser alignment system with dual PSDs

**PSD Signal Processing:**

PSD is a photoelectric device that converts an incident light spot into four photoelectric currents, which can be calculated to continuous position data. Most of the calculations are based

on the circuit by ACU (Analog, Computational units). In that way, the light spot position data were converted to a voltage signal, which can be acquired by ADC (Analog- to- digital converter). Nevertheless, those components in circuit such as amplifier or ACU will bring some additional noises to the system which is difficult to reduce. We adopt a method that calculates the light spot position by an SCM (Single Chip Micryoco), MSC1210, which is a mixed signal device incorporating a high-resolution delta-sigma ADC, an 8-channel multiplexer, and an 8-bit microcontroller. Therefore, one MSC1210 completely deals with eight channels signals of the two PSDs. Only a little component is needed in the signal processing circuit. It improves the stability of the detector unit by greatly decreasing the electro-circuit noise.

**System Design:**

The laser alignment system with dual PSDs is comprised of two small measuring units (laser transmitter and detector) and a PDA with measurement software.

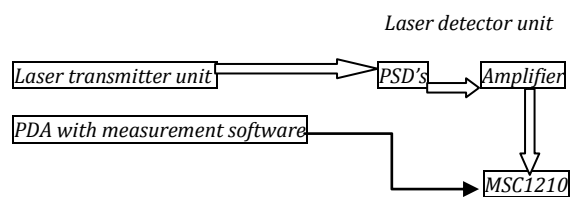

Fig.3 The laser alignment system with dual PSDs

**Laser transmitter unit:** The laser transmitter unit is made up of diode laser and the mechanism with built in micrometer screws for adjustment of the laser beam in horizontal and vertical level. From the PSD response spectrum, the peak sensitive wavelength of this PSD is 960 nm, but it is necessary that the light must be visible when the operator adjust the angle of incidence at the pre-alignment of shaft calibration. So the 635 nm diode laser was selected in the visible wavelength region. Because of the PSDs feature which is sensitive to the light spot barycenter, the light wavelength or intensity does not hamper the precision of the light spot position.

**Laser detector unit:**

PSDs and the PSD signal processing circuit comprise the laser detector unit. In the dual PSDs signal processing, the method adopted is similar to the signal processing, i.e., use software arithmetic to calculate the values of the laser spots position on PSD to replace the pure circuit method which usually involves many components between detector and CPU, such as ASU, ADC, etc. These components will bring to the system some additional noises that are difficult to reduce. An SCM, MSC1210, has been selected as the key chip of the detectors. The MSC1210 includes a 24-bit resolution ADC

consisting of an input multiplexer (MUX), an option buffer, a programmable gain amplifier (PGA), and a digital filter.

The PSD sensor and CPU are connected directly. It was proved in a laser test that this method can efficiently remove those noises and improve the system accuracy and stability.

The photoelectric currents generated by PSD flow through the amplifier circuit and are converted into voltage signals. Then MSC1210 converts those to the PDA through RSC232. The software on the PDA calculates the position of the light spot when the data is received.

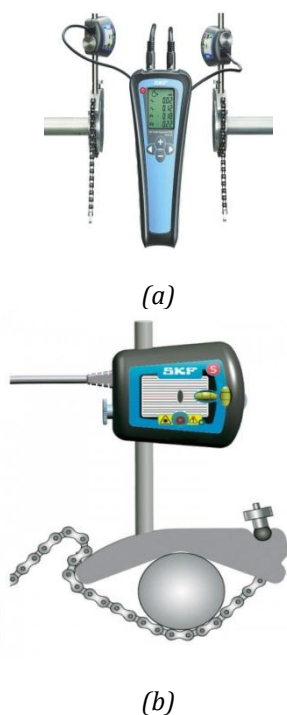

Fig.4 Laser Transmitter and Detector unit

(a) Detector and (b) Transmitter unit

**Measurement software on the PDA:**

During shaft calibration, the laser transmitter and detector units are mounted on the stationary and the movable machine, respectively. After the measurement software is started, the program may ask for every necessary distance datum, and then, must measure and input the distances between the measuring units and feed the software, after the software waits for the data of the laser detector unit. The whole measurement is carried out step by step on the display. The shafts with measuring units are turned to position 9 o'clock, and then 12 o'clock, and finally 3 o'clock, after which offset, angular values and shim adjustment values are clearly displayed on the PDA screen. Both horizontal and vertical values are shown "live", so that it is easy to adjust the machine.

**Laser beam calibration at pre-alignment:**

To obtain the best possible conditions for shaft alignment, it is necessary to check whether the incidence angle of the laser beam projected to the PSD surface is perpendicular. From Fig.2, we know only if the laser spot on each PSD is at the PSD center, the laser light can be said to be perpendicular incident to the detector unit. Therefore, in the self-calibration software, we defined an acceptable range to adjust the laser transmitter unit. As Fig.6 describes, if the spot position is out of the inner circle (radius=25.4 μm), we screw the four dimension adjustment in the laser transmitter until the spot falls into the circle.



(a)



(b)

Fig.5 Laser beam calibration at pre-alignment

(a) Before adjustment; (b) after adjustment

**ALIGNMENT PROCEDURE:**

Experimental setup rig attach the measuring units to the shafts, the S unit is mounted on the stationary shaft machine, M unit is mounted on movable machine and tighten the chain by hand and finally tighten using Tommy bar, usually the motor in the same manner as the S unit. Next fit M & S cables have to be connected to the display unit a ranger cable so they do not fail the machine. Pay attention to the marking on the cable and on the unit get the M cable to the M socket and S cable to the S Socket.

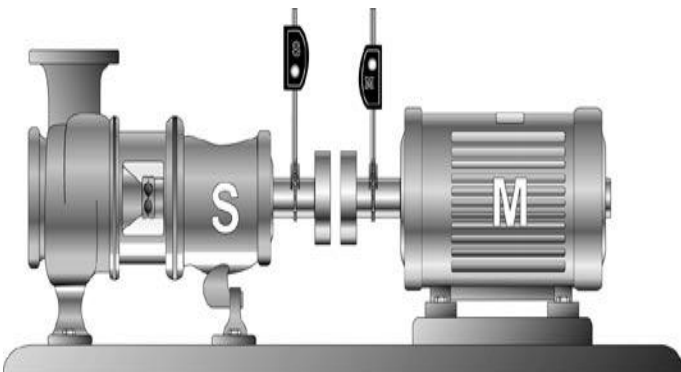
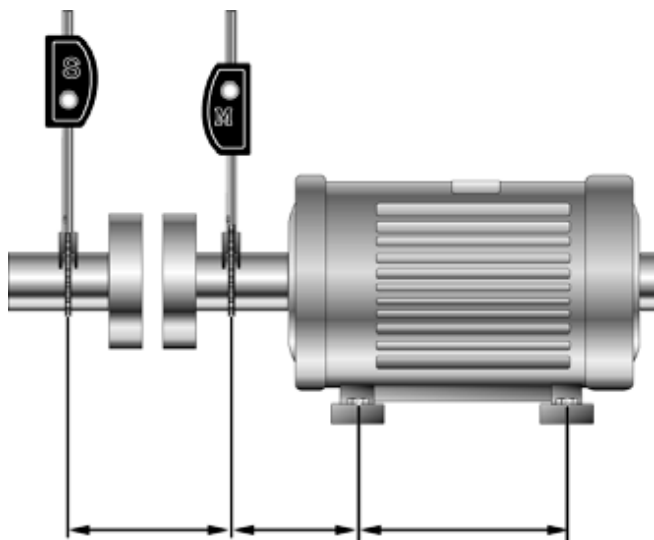

Fig.6 stationary and movable alignment system

Turn on the display unit and adjust the laser lines to the center of the detector. Fine adjustments can be made by using the fine adjustment will measure the machine dimensional using a tape measure, first measure the distance between the measuring units. This is the A Distance. Use a Plus or minus (+/-) buttons to adjust the value and confirm by using the next buttons. The B value now needs to be measured; the B value is the distance from the Centre of the movable machine measuring unit to the front foot of the motor. Enter the value into the display unit and confirm, finally the C value needs to be measured, the C value is a distance between the motor feet, enter the value into the display unit and confirm.



A = 142 mm B= 95 mm C=100 mm

(a)

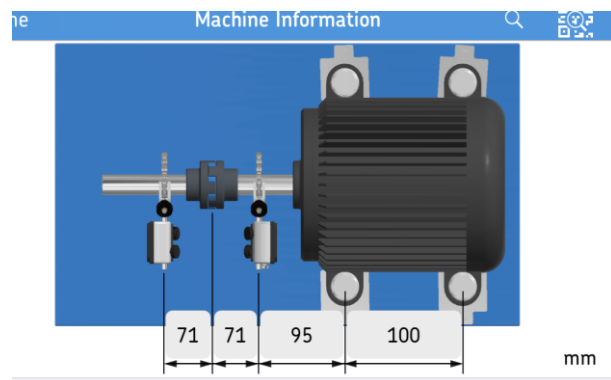

A B C D

(b)

Fig.7 Machine Dimensions

(a) Machine Dimensions as per TKSA 20 (b) Machine Dimensions as per TKSA 11 & 80

The display indicates move the motor in units to the nine (9) o'clock position. The spirit levels help you to get to the right position, once a nine (9) o'clock press for next button the display indicates to the measuring units to the three (3) o'clock position move the measuring units to the three (3) o'clock position and then press next. The display shows a live horizontal motor misalignment both coupling and feed values. It is recommended to correct the vertical alignment, the first move the display units to the twelve (12) o'clock position and the display shows a live vertical motor misalignment values.

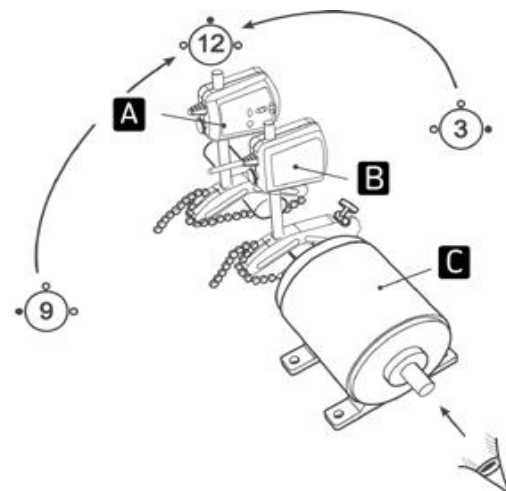

Fig.8 The analogy of a clock

Check the values gain the tolerance values provided, select the shim required to make the vertical correction. The F1 values refer to the front feed correction and the F2 values refer to the back feed corrections; loosen the entire motor support box to allow the motor to be positioned. Lift the and trim the front feed and then the back feet as required. The display unit shows your progress the machine is now aligned in the vertical plane to perform the horizontal alignment correction, move the

measuring units to the three o'clock position for the live horizontal motor misalignment values or shown under the display unit. The alignment is out of tolerance, the motor needs to be moved horizontally, back of a display unit indicates the movement directions, move the motor carefully until the reading on the display unit are in tolerance. Once completed carefully tighten the bolts, press the back button twice and repeat the alignment procedure, measuring at Nine (9), Three (3) and Twelve (12) O'clock and make report.

Speed (rpm)	Angular Error (mm/100)	Offset (mm)
1000-2000	0.08	0.10
2000-3000	0.07	0.07
3000-4000	0.06	0.04
4000-5000	0.05	0.03
5000-6000	0.04	<0.03

Fig.9 Tolerance standard as per speed of movable machine

**RESULT AND DISCUSSION:**

Shaft alignment rig fig.1 is used to study of the Procedure of the laser alignment of shaft for rotary machine. The test is performed as that in the SKF alignment method (SKF TKSA11). Initially put the value of A, B, C and d in the display unit and find the value of misalignment vertical angle 0.14 mm/100, vertical offset -0.31 mm and horizontal angle 0.16, horizontal offset -0.38 mm. As per this value shims required of 0.08 mm and 0.05 mm for proper alignment of 0.00 mm front and rear foot. After the test we list the measured value in fig.7 and Fig.10. From fig.10 and fig.11, we can see the results of laser alignment of rig with PSD's by TKSA 11 are more precise.

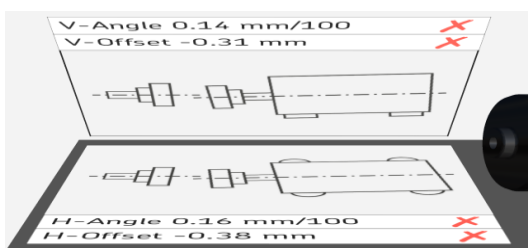

(a)

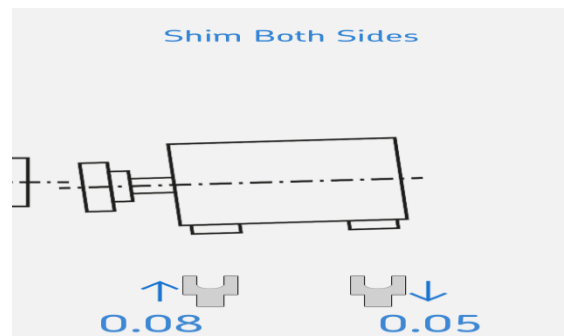

(b)

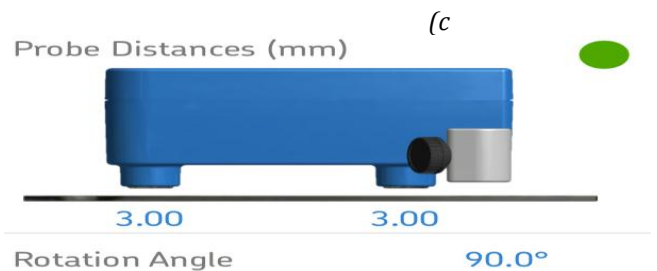
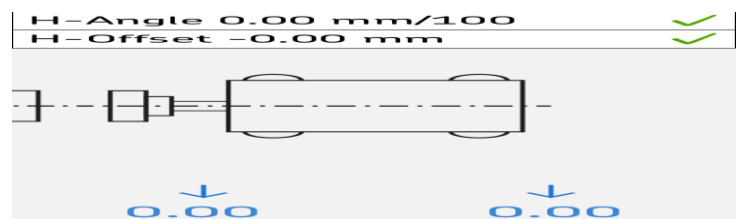

(d)

Fig.10 Alignment Procedure represented by resultant images

(a) Misalignment value represented

(b) Shims required for alignment

(c) Proper alignment shown

(d) Balancing of Front and Rear foot

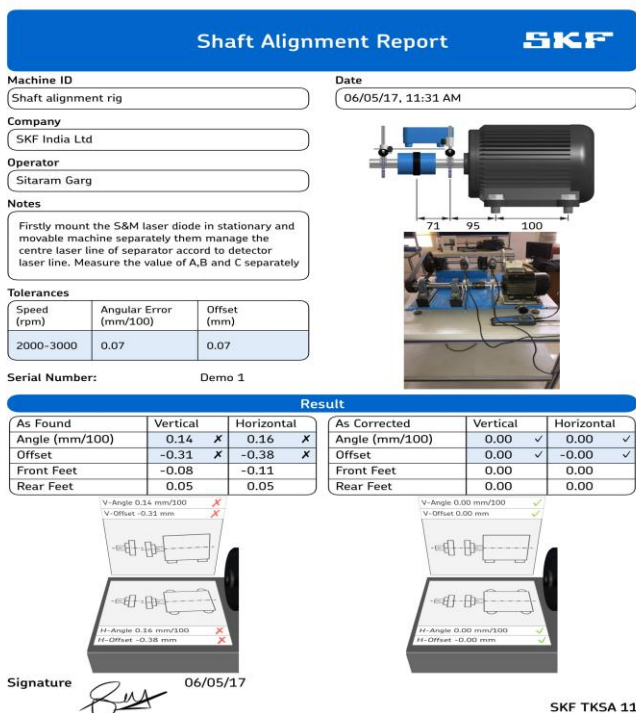

Fig.11 Shaft alignment report designed by Software

**CONCLUSION:** Much like the philosophical change from shafts alignment with dial indicators to shafts alignment with laser - based systems, these types of measurement will take some time to be generally accepted and routinely practiced. The laser alignment system described above will lead to lower misalignment levels, increased mean time between failures, decreased maintenance expenditures, and increased production, reduced 50% of premature bearing failures, reduce Shaft fatigue, reduce Sealing problems, decrease vibration, decrease overheating and improve excessive energy consumption.

**ACKNOWLEDGEMENT:**

The Author wish to thank SKF India Ltd Pune and MITS Engineering college Gwalior, for support and his permission to publish this work.

**REFERENCES:**

- I. SKF shaft alignment method by SKF India Ltd April 2015 to March 2016.
- II. Fluke Shaft alignment method by Fluke U.K. 2014 - 2015.
- III. Pruftechnik Rim & Face dial alignment and Laser shaft alignment method 2014.
- IV. Brommundt, E., kramer, E., 2005. Instability and self-excitation caused by a gear coupling in a simple rotor system. *Forschung im Ingenieurwesen*, 70(1):25-37. (doi:10.1007/s10010-005-0011-3)
- V. Hamamatsu Photonics, 2001. Operating Principle and Features of PSD. Hamamatsu, Japan.

- VI. Jiao, G.H., Li, Y.L., Hu, B.W., 2006. Development of the laser alignment system with PSD used for shaft calibration. *Proceedings of SPIE- The international Society for Optical Engineering*, 6150:61500.
- VII. Jin, G.F., Li, Z.J., 1998. *Method of Laser Measurement*. Science press, Beijing, China, p.697-700 (in Chinese).
- VIII. Lee. G., 2004. Taking Accurate Vibration Measurements. [Http://www.mt-online.com/articles/index.cfm](http://www.mt-online.com/articles/index.cfm)
- IX. Luedeking, A., 2003. Using Laser to Align Cooling Tower Fans. [Http://www.rsesjournal.com](http://www.rsesjournal.com)
- X. Luedeking, A., 2005. Laser Alignment Verification- On site at the largest Gas Turbine in the U.S. [Http://www.ludeca.com/casestudy.htm](http://www.ludeca.com/casestudy.htm)
- XI. Pan, H.J., Liu, Y., Chen, J., 2005. Analysis of a link state of a coupling. *Mechanical Science and Technology*, 24 (8):894-897 (in Chinese).
- XII. Perry, S., 1998. Dealing with Positional change of on-line machinery. *Maintenance Technology*, 11 (10):44-52.
- XIII. Perry, S., 2001. Alignment monitoring and corrections of a Turbine Driven Feed Water Pump. [Http://www.ludeca.com](http://www.ludeca.com)
- XIV. Piotrowski, J., 1995. *Shaft Alignment Handbook* (2nd. Ed.). marcel Dekker Inc., New York, p.67-69, 115-118.
- XV. Studenberg, D., 2002. Precision Shaft Alignment: What's the Right for you? [Http://www.mt-online.com/articles/index.cfm](http://www.mt-online.com/articles/index.cfm)
- XVI. Texas Instruments, 2002. Datasheet of MSC1210. [Http://www.ti.com](http://www.ti.com)
- XVII. VibraAlign Inc., 2002. Dynamic Movement White Paper. [Http://www.vibralign.com](http://www.vibralign.com)
- XVIII. A laser shaft alignment system with dual PSDs by JIAO Guo-hua, LI Yu-lin, HU Bao-wen, LI Tong-hai, ZHANG Dong-bo, 2006.
- XIX. The Design and Develop of A Laser Shaft Alignment Instrument based on the Two Dimensional PSD, Mu Li\*, Wang Xinwel, 2012.

**BIOGRAPHY:**



<sup>1</sup>Sitaram Garg, Student of the Master of Technology in Machine Design, Department of Mechanical engineering, C.B.S. group of institutions Jhajjar Haryana, Former Mechanical engineer of JSW Steel Ltd Nagpur Maharashtra India.