

WebPage Based Industrial Automation

Ganesh Bhadane¹, Nisha Shinde², Geet Chaudhari³, Reshma Patil⁴

^{1,2,3}Student, Dept. of ENT C Engineering ,Dr.D.Y.Patil college of engineering Ambi,Maharashtra,India

⁴Professor, Dept. of ENT C Engineering Dr.D.Y.Patil college of engineering Ambi,Maharashtra,India

Abstract - This paper presents a design and prototype implementation of new industrial automation system that uses web server technology which can be used to communicate with the system remotely. This project highlights a few of the important instrumentation and control loops that are required for safe, economic and reliable working of the boilers and Industrial premises. In this we are monitoring and controlling important parameters with which the process output will be steady output. Here we are using sensors for the parameters are Temperature sensor, Moisture sensor, Level sensor, LDR, PIR & IR sensor. It introduces design of WEB server based on ARM 7 processor and Internet controller. In various internet application based on client/server architecture, it is better to use web server rather than PC server for decreasing size, cost and power consumption. This WEB server can be used in various applications like industrial, agriculture and home automation. This paper proposes a review on remote monitoring and control of industrial plant parameters. The proposed system consists of two main components; the first part is the sensor. Second part is the server (web server), which presents system manages, controls, and monitors industrial plant. Users and system administrator can manage and it control by entering correct password.

Key Words: LPC2148, WEB SERVER,SENSORS,GPRS,BOILER AUTOMATION

1. INTRODUCTION

Industrial work is all has become so dependent on automation that it impossible to do work in any industrial organization automation engineering is required. Trade, environmental protection engineering, agriculture, building engineering, and medical engineering are some of the areas where automation is playing a chief role. Automation engineering is nothing but the control engineering dealing with a number of electrical and electronic appliances. Every equipment and elements has computers & software base for communications and automation. This can help any organization to save their money & time. A web server provided here for uploading the web pages. When the configured IP address is enter in the web browser, HTML web pages gets displayed through which the client can monitored the sensor status. ARM7 processor is the prime controller of web

Server, ARM Processor is selected here because ARM has high data processing efficiency. We can also handle the various parameters regarding with boiler. The sensor

module is an ARM for supervision and controlling the various parameters of a plant.

2. BLOCK DIAGRAM

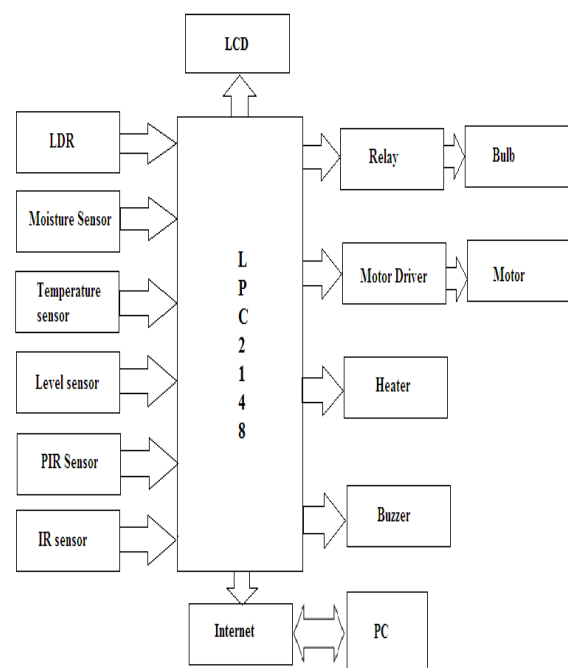

FIG. -1: Block diagram of system

Block diagram of Webpage based industrial automation for boiler system is shown in Fig 1. ARM7 is the prime micro-controller of the system. ARM 7 acts as the server of the system.

The admin can handle & control the devices. These commands are getting through the server by opening the web page, and the controller will send & receive the signals from the sensors and relays respectively. Several sensors used in this project are LDR (Light Dependent Resistor), humidity sensor, temperature sensor, water level sensor, PIR (Pyroelectric Infrared) sensor, IR (Infrared) sensor which is used to monitor overall industrial automation system. The server can get entrants from anywhere if internet connection is available. All the real time data from the various sensors and modules will be updated in the server continuously. Thus the surveillance of industry can be done by user from anywhere and can control the plant and various machines remotely.

2.1 LPC2148

The system uses LPC2148 from ARM7 family. It is the core controller in the system. It has ARM7 TDMI core which is a member of the Advanced RISC Machines (ARM) a family of general purpose 32-bit microprocessors. It is high performance for very low power usage and price. The ARM architecture is used on RISC (Reduced Instruction Set Computer) architecture. The micro-program of instruction set and decode mechanism are very easy than the CISC (Complex Instruction Set Computers) architecture. Hence, high instruction throughput and impressive real-time interrupt response is small and cost-effective chip. All parts of these systems can operate continuously since, pipelining is employed. Generally, while one instruction is being executed, its successor decoded, and a third instruction is fetched from memory. The ARM memory interface has been designed to allow the performance actual to be realized without remitted high costs in the memory system. Speed-critical control signals are pipelined for allow system control functions to be implemented in standard low-power logic, and these control signals impede the absorption of the fast local access modes offered by industry standard dynamic RAM.

2.2 LDR

LDRs or Light Dependent Resistors are useful particularly in light or dark sensor circuits. It is depend upon light intensity, also works on photo conductivity on materials used.

2.3 Moisture sensor

Moisture/Humidity is generally presence of water in air. It is affect to human ease as well as no of manufacturing processes in industries.

2.4 Temperature sensor

The LM35 is a infallibility IC temperature sensor. And output is proportional to the temperature (in o C). The LM35 temperature is measured more rigorously than with a thermistor.

2.5 IR SENSOR

An infrared sensor is an electronic device, used for counting purpose. The no. of person entered in industry is counted by this sensor. IR sensor can measure the heat of an object and detects the motion.

2.6 PIR SENSOR

PIR sensors sense motion; it is detect the heat of the live body. It is small, cheap, low-power, easy to handle and we don't wear out.

2.7 LEVEL SENSOR

It senses the level of liquid. It is works on threshold value. The ultrasonic sensor is used as a level sensor to observe the liquid level.

3. FLOWCHART

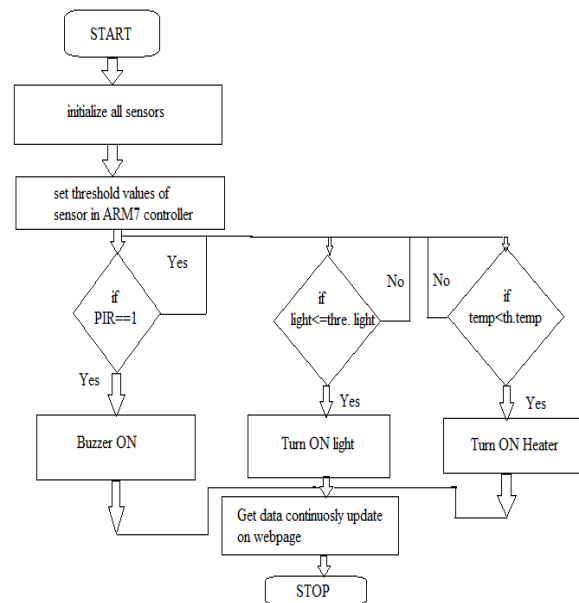

3. CONCLUSIONS

The Implementation of Web Page Based Industrial Automation modem took advantages of the stability and reliability characteristics. Additional, the system also contains the original verifying methods which were inputting owner's password which is send by the controller. The security features were enhanced largely for the stability and reliability of owner recognition. The whole system will be built on the technology of embedded system which makes the system more safe, reliable and easy to use. Additional, system also contains security of plant itself which is used more Sensors,

REFERENCES

- [1] "Embedded Web Server for Home Appliances", IJERA, Mar'12 by Mr. Abhishek
- [2] "ARM Embedded Web Server Based on DAC System", 2011 IEEE by M Poongothai.
- [3] "Design and Implementation of an Embedded Webserver Based on ARM", 2010
- [4] "ARM microcontroller based Industrial Automation System", IJAREEIE, Vol. 3, Special Issue 4, April 2014 by Nagisetty Sasidhar and Monica P. Suresh.