

Automatic Irrigation Using Wireless Sensor Network

Umesh¹, Shashanka D¹, Rajesh¹, Kangzamba Yumnam¹, Dr.C.R. Venugopal²

¹ The National Institute Of Engineering, Mysore

² Asst. Prof Dept. of E&C Engineering, The National Institute Of Engineering, Mysore, Karnataka, India

Abstract - The automatic irrigation system is developed to optimize enhance watering for farming crops. The system has a distributed wireless sensor network which consist of soil moisture and temperature sensors which are placed in the root zone of the soil and the sensor network also has the humidity sensor to determine the humidity of the surrounding. In addition, a gateway system handles the information obtained from sensors, triggers and transmit the data on to a web application. A principle was developed with the threshold values of soil moisture and temperature which was programmed into microcontroller based embedded system to control watering to the plants in controlled manner. The embedded system was powered by AC source and had a full duplex communication link based on cellular internet interface which allowed for inspection of the data obtained from the sensors and based on data analysis the irrigation is done. The data that is continuously generating is stored in MQTT server and that data is used to generate the graphs of soil moisture and temperature over a period of using GUI (graphical user interphase) application.

Key Words: wireless sensor network, soil moisture sensor, temperature, humidity, microcontroller, MQTT server, GUI.

1.INTRODUCTION

On the earth, 3/4 of the land is covered by water and among that water only 3% of water is consumable which is fresh water. In farming, more than 85% of water is being used. As due to rapid population growth the demand for water from cities and industries in increasing the traditional way of irrigation methods are no longer suitable so, there is urgent need to create strategies using science and technology for proper use of water for irrigation.

To achieve water savings in various crops there are so many systems are available from basic ones to more technologically advanced systems. Our work uses a low cost wireless sensor network along with wireless communication device for data communication. An automated irrigation system is developed which consist of soil moisture sensor, temperature sensor and humidity sensor. To monitor the crop condition such as soil moisture, temperature a data collecting system was developed. The system collects the data such as soil moisture, temperature of soil and that data can be downloaded through a computer connected to same network as that of the system.

In this system to develop the automated irrigation system which is based on microcontroller and wireless communication system is presented. the main aim of this system is to minimize the water usage for irrigation using the automated irrigation system which monitors the soil moisture and temperature of the soil. In our work, we are using 3 sensors are soil moisture sensor, temperature sensor and humidity sensor which are interfaced with 8051 Atmel microcontroller. The data obtained by the microcontroller using all the sensors is transmitted using a Wi-Fi module. And based on readings obtained from the sensors motor pump is used to irrigate the field. If the soil moisture is below threshold level then automatically motor pump will switch on to irrigate the soil and immediately soil moisture readings are obtained in LCD display which is interfaced with the microcontroller. The communication between the sensors and data receiver is using the Wi-Fi module. We are using Grafan software to develop the graph and to set threshold value based on the readings obtained from the sensors.

1.1 NEED

Today's world is digital. In this 21st century, country like India where farming is the backbone of the country, needs automation. As we know farming is the vital and broad field for our country's financial system. So, we are trying to instigate the technology which is helpful for farming hence we are instigating Automation Irrigation Using Wireless Soil Sensor Network system so that the water is used in less and very efficient manner for irrigation. It makes the irrigation process more effective and workers can concentrate on other important farming tasks.

1.2 METHODOLOGY

A) Proposed Design

In our venture, we are going to use two unit

- 1) WSU Unit i.e. wireless sensor unit
- 2) WIU Unit i.e. Wireless information unit.

B) Hardware and Software Requirement

1. PC and MATLAB
2. Keil Software

3. Atmel 8051 Controller
4. 16x2 LCD
5. Relay
6. Temperature Sensor
7. Humidity Sensor
8. Soil Moisture Sensor
9. Wi-Fi Module
10. Motor
11. MQTT Server

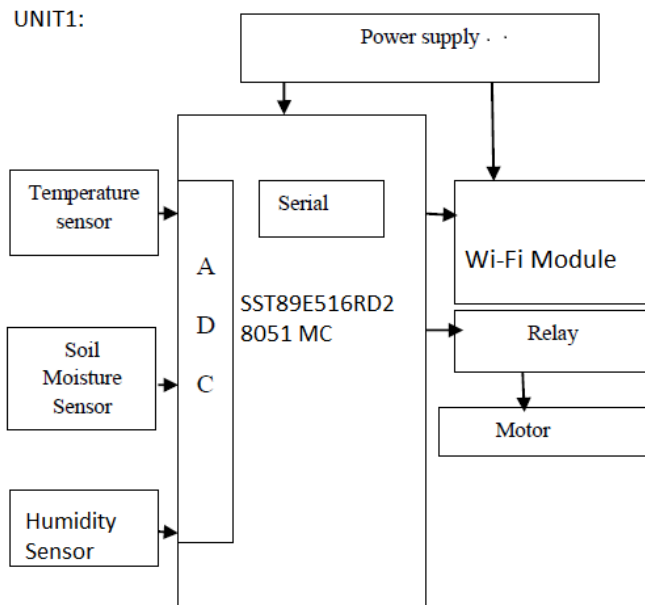

Fig - (1) WSU Unit (wireless sensor unit)

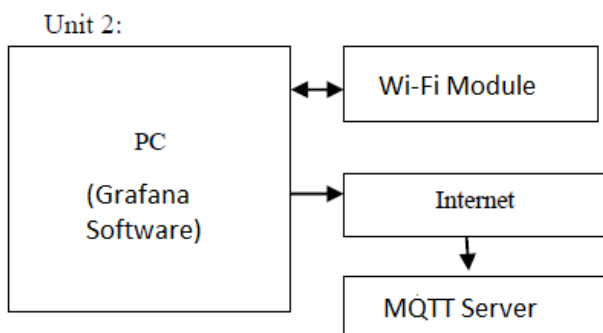

Fig - (2) WIU Wireless Information Unit

C) Automated Irrigation system:

The Automated irrigation using wireless sensor network system consist of two unit WSU i.e. Wireless sensor unit it is connected to the network that allowed the transfer of soil moisture data, temperature data and humidity data for this it uses XBee technology and we are using a Wi-Fi module to transmit the data to a web server via the public mobile network. The data information can be remotely accessed online using internet access devices and using Wi-Fi network available in Smartphone.

a) Wireless Sensor Unit:

A WSU is consisting of RF transmitter and receiver, Sensors, microcontroller and power supply sources. A low cost, vigorous, wireless sensor that provides long period of durable operability without any hectic maintenance. Wireless sensor is made to communicate with a central base unit. The sensor unit continuously detects the moisture, temperature the sensors communicate with the central base unit and provides data. Several WSU can be added into the field to configure distributed sensor network for the automated irrigation system using wireless sensor network. WSU unit consist of a SST Controller, sensors, Wi-Fi module, LCD and Motor. The sensor we are using in the system are soil moisture sensor, temperature sensor and humidity sensor which are interfaced with the controller. Based on data obtained from the sensor unit the controller will operate the motor. Wi-Fi module is also interfaced with the controller which transfers the data to the PC and MQTT server.

b) Wireless Information Unit:

This unit consist of PC, Wi-Fi module and Internet. Soil moisture, temperature and humidity data are received and processed using MATLAB and this data are send to the other devices using internet through MQTT server.

2. Principle of operation

a) Working of a WSU Unit:

In this project, MATLAB is used to collect data from WSU and that data is used to represent it graphically.in this project we are using 2 WSU unit i.e. Wireless sensor unit in which. we are using SST Controller to that 3 sensors are interfaced, Wi-Fi module and one motor is placed at the field side. WSU programming is done using KEIL software and it is loaded into the controller.

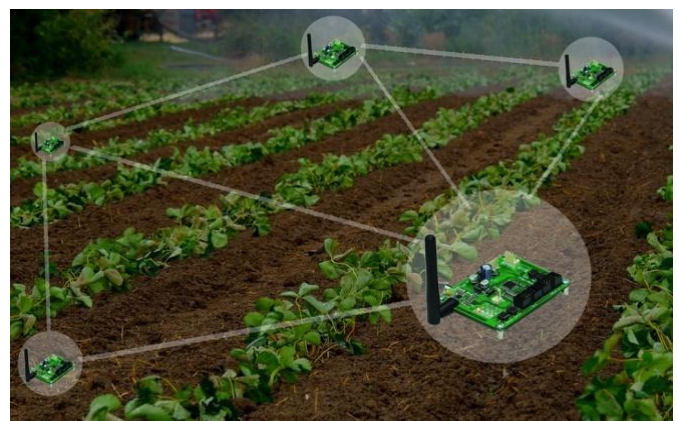

Fig 3: WSU Unit present at the field site.

b) Components used:

The motor is controlled by SST microcontroller. Motor is used to pump water to the field. In our work, we are using 3 types of sensors Temperature sensor i.e. LM35, humidity sensor, Soil moisture sensor. Relay is also used for switching motor on and off. We are also using Wi-fi module for serial communication which transmits the data obtained from the sensors to the PC and using MATLAB software the data is analyzed and represented graphically We are using SST controller of type SST89E516RD2 this controller is easy to program. It is CMOS flashed based 8-bit controller. It has 44 pins, 3 16-bit timers. It has Super Flash EEPROM-64 Kbyte primary block +8 Kbyte secondary block (128-Byte sector size for both blocks), self programming.

Fig 4 shows software flowchart of proposed system

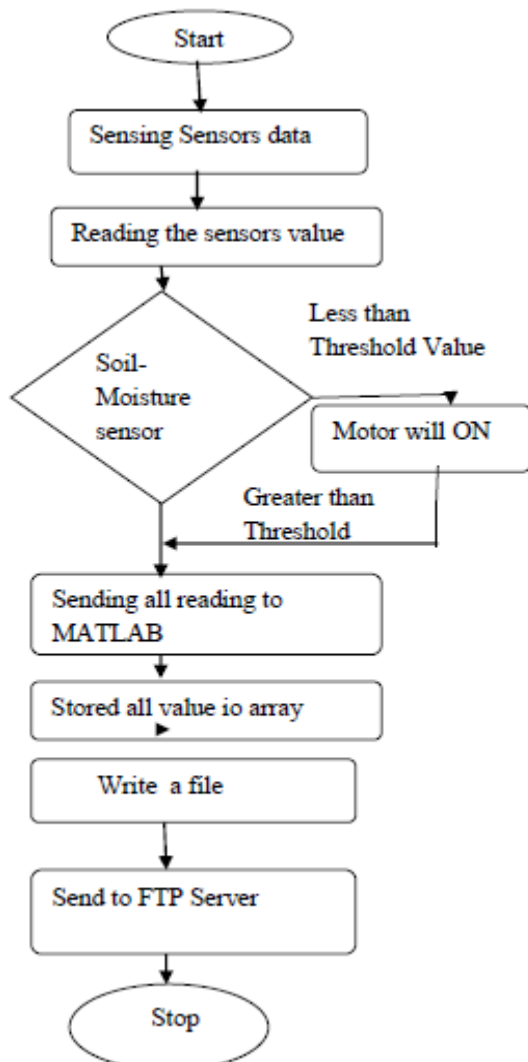

Fig 4: Software Flowchart

In above software flowchart, whole software process of the system is shown. The MATLAB will receive data from controller with the help of Wi-Fi module and sending this to the MQTT Server.

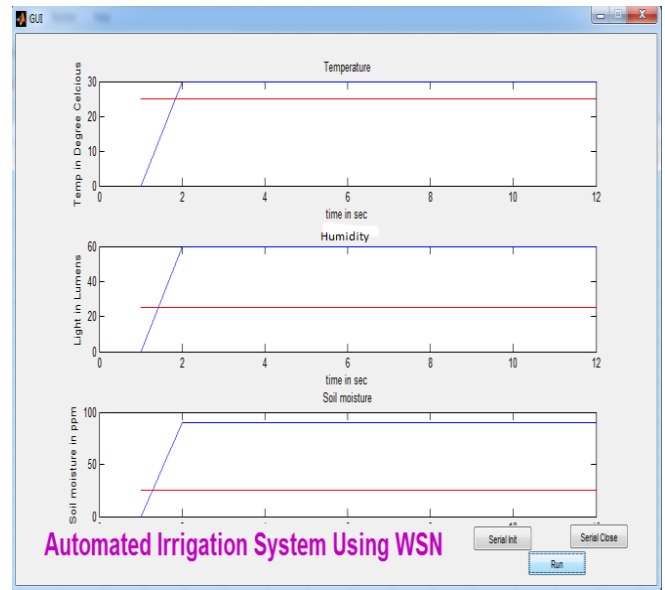

Fig 5: Output when MATLAB Code calculating Sensors Value

3. CONCLUSIONS

The automated irrigation system using WSN implemented is found to be suitable and cost effective for optimizing water resources for agricultural cultivation. This irrigation system allows cultivation in places with water scarcity thereby improves its sustainability.

4. REFERENCES

[1] W.A.Jury and H.J.Vaux ,”The emerging Global water crisis: Managing Scarcity and conflict between water users.” Adv.Agrmy,vol.95,pp.1-76

[2] Forrest S.Melton,,Lee F.Johnson ,Edwin.J.sheffner,and Ramakrishna , ”Satellite Irrigation Management Support with the Terrstrial Observation and Prediction System: A Framework for integration of Satellite and Ein Agricultural Water Resource Management .”IEEE journal Vol 5,No 6,December 2012.

[3] A.Kumar,K.Kamal,M.O.Arshad,T.Vadamala ,S.Mathavan ,”Smart Irrigation Using Low-Cost Moisture Sensors and XBee-based Communication” .IEEE 2014 Global humanitarian Technology conference.

[4] Joaquin Gutierrez Jaguey ,Jaun Francisco, Villa-Medina ,Aracely Lopez -Guzman.and Miguel Angel Porta- Gandara, ”Smartphone Irrigation Sensor” IEEE sensors journal .vol.15.No.9.Sep 2015.

[5] B-G, Lee and W.Y. Chung .”Driver alertness monitoring using fusion of facial features and bio-signals.”IEEE sensors J.,12,no7,pp.Jul .2012