

Pain Relief through Electrical Stimulation

Divya Singh¹, Jyuthika Sen², Yashpriya Sharma³, Prof. S. P. Tondare⁴, Prof. S. P. Gaikwad⁵

¹Divya Singh, B. Tech Biomedical, Department of Electronics, Bharati Vidyapeeth College of Engineering, Pune, India, (e-mail: divyapune789@gmail.com).

²Jyuthika Sen, B. Tech Biomedical, Department of Electronics, Bharati Vidyapeeth College of Engineering, Pune, India, (e-mail: sen.jyuthika26@gmail.com).

³Yashpriya Sharma, B. Tech Biomedical, Department of Electronics, Bharati Vidyapeeth College of Engineering, Pune, India, (e-mail: yashpriya.rimi@gmail.com).

⁴Prof. S. P. Tondare, Assistant Professor, Department of Electronics, Bharati Vidyapeeth College of Engineering, Pune, India, (e-mail: sptondare@bvucoep.edu.in).

⁵Prof. S. P. Gaikwad, Assistant Professor, Department of Electronics, Bharati Vidyapeeth College of Engineering, Pune, India, (e-mail: spgaikwad@bvucoep.edu.in).

Abstract - A Pain Relief unit provides electrical stimulation to the painful area using electrodes attached to the skin. The electrical energy is applied in the form of mild, electrical impulses. The impulses pass through the skin and interact with the nerves that lie underneath the skin. The electrical impulses act on the nervous system in such a way as to suppress the sensation of pain that would otherwise serve as a protective mechanism. We can set this machine for different frequencies used for different intensities of pain. The impulses are in the form of a steady flow of electrical current or a burst of electrical current.

Key Words: Electrical Stimulation, Pain Relief, Electrical Impulse.

1.INTRODUCTION :

Electrical stimulation is used for nerve related pain conditions. This therapy uses low-voltage electrical current for pain relief instances. The stimulating pulses help prevent pain signals from reaching the brain and the device also helps stimulate our body to produce higher levels of its own natural painkillers called endorphins.

Pain is felt as a result of the brain's response to electrical (neural) and chemical (hormonal) changes in the body as a result of damage. Signals from the damaged area or injured site are picked up by the sensory receptors in the nerve endings. The nerve endings then transmit the signals via the nerves to the spinal chord and then the brain.

Pain can be managed in the short term using analgesics, but long-term use can be detrimental to the patient's health. Side effects of the long use of analgesics may have an effect on the liver, kidney or stomach. Permanent pain relief methods include extensive procedures like surgery.

However, in many cases where the pain is constant, a Pain relief unit is the most recommended method because it is a non invasive, safe, and effective method virtually with almost no side effects.

People use this apparatus to relieve pain for several different types of illnesses and conditions. They use it most often to treat muscle, joint, or bone problems that occur with illnesses such as osteoarthritis or fibromyalgia, or for conditions such as low back pain, neck pain [1]. People also use this machine to treat sudden (acute) pain, such as labor pain, and long-lasting (chronic) pain, such as cancer pain [2].

The stimulation delivered by this device excites the sensory nerves and in turn activates specific natural pain relief mechanisms in the body. There are two theories related to the pain relief mechanisms namely:

The Gate Theory: Pain signals from the body travel towards the brain where they are processed and pain is felt. Hence during the stimulation the tingling sensations from the unit goes to the brain instead of pain signals from body which in turn blocks the pain signals and thereby relieving the patient from pain.

The Opiate Theory: With respect to this theory, on application of this device pain relief hormones are released in the body called endorphins which help the patient to overcome the pain.

2. METHODOLOGY

The block diagram for the Pain relief unit is given below:

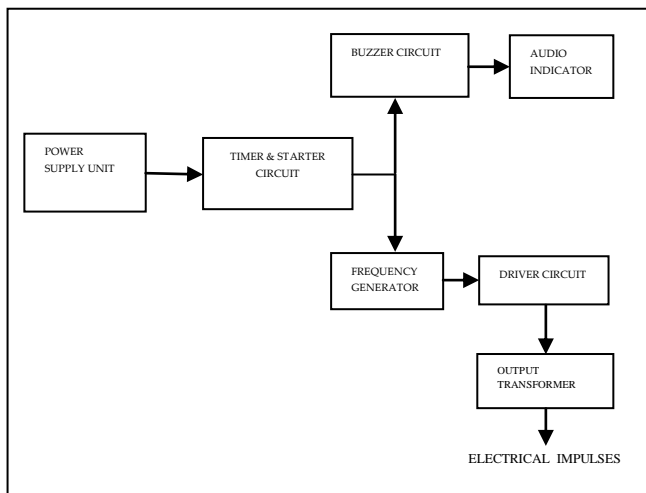

Figure 1: Block diagram of the Pain Relief Unit.

As shown in Figure 1, the power supply of 5V is designed to run the circuit. A trigger pulse is used to start the timer and starter circuit. The output from the timer and starter circuit is given to both, the frequency generator circuit as well as the buzzer circuit. The buzzer circuit is used as an audio indicator to indicate when the stimulation is taking place. The output from the frequency generator circuit is amplified using a driver circuit and given to the output step-up transformer. The electrical energy is applied in the form of mild, electrical impulses. The output pulses which are transmitted reach the pain area or pressure point using disposable electrodes.

The circuit diagram for electrical stimulation is shown in Figure 2.

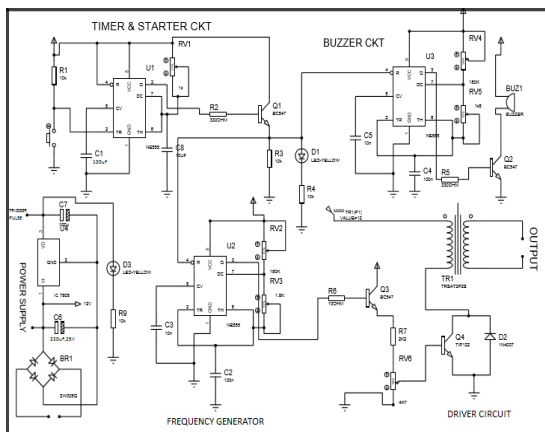

Figure 2: Circuit diagram of the Pain Relief Unit.

3.1 POWER SUPPLY UNIT

A 5V Power supply unit consists of transformer, bridge rectifier, filter circuit and regulator. This unit comprises of a Step-down transformer having a 50:1 turn ratio which steps-down the 230V AC to 5V AC. Rectification then takes place to convert the AC into DC. This is done using a bridge rectifier circuit consisting of four diodes. The pulsating DC got after the rectification stage is passed through a capacitor filter to get pure DC. An electrolytic capacitor (2200µF, 25V) is being used. It is a high temperature radial capacitor. The 15V DC is stepped down to 5V DC using a voltage regulator. Thus the 5V DC output obtained is used to run the circuit. A LED detector is being used as a visual detector which remains ON during the working of the power supply and OFF when the power supply is offed.

3.2 TIMER AND STARTER CIRCUIT

The 555 Timer IC is being used in the Timer and Starter circuit. The Pin 2 in the 555 timer is a trigger input. The Trigger pulse is a narrow negative going spike. A differentiator circuit made from capacitor C7 and resistor R9 will produce two symmetrical spikes but the diode which in this case is the LED D3 is used to eliminate the positive going spike.

The 555 timer IC is being used as a monostable multivibrator which produces accurate and highly stable time delays. Here the Pin 1 is grounded. Output is taken from pin 3. Pin 4 is usually connected to + Vcc to avoid accidental reset. Pin 5 is grounded through C1 which is a 100µF capacitor to avoid noise problem. Pin 6 (threshold) is shorted to pin 7. The resistor RV1 is connected between pins 6 and 8. At pins 7 a discharge capacitor C8 is connected while pin 8 is connected to supply Vcc.

When the push button is pressed, the voltage at the trigger pin drops low and the output pin turns on. At the same time, the discharge pin stops the flow of current from C8 to ground, allowing it to charge. C8 takes time to charge and while the voltage across it is below 2/3 Vcc, the threshold pin remains low so the output pin stays on. When the charge finally builds up enough to make the voltage across C8 greater than 2/3 Vcc, the threshold pin switches off the output pin. At the same time, the discharge pin switches back on and prevents the capacitor from charging until the button is pressed again.

An LED is attached to the output pin of the IC. The length of time the LED remains on is a function of the time it takes for the capacitor to become charged to 2/3 Vcc. It's also determined by RV1, since the resistor prevents the flow of current to the capacitor and thus increases the time it takes for the voltage across it to reach 2/3 Vcc.

The output from the timer and starter circuit is being used to drive both, the frequency generator circuit as well as the buzzer circuit.

3.3 BUZZER CIRCUIT

The buzzer circuit is driven by the output of the timer and starter circuit. It gives the audible indication of the stimulation taking place. It consists of a couple of resistors, capacitors and 555 timers which are set up as astable multi vibrator. In an astable mode, there is no stable state and the pulses are generated at low and high state in square wave form.

To control the ring duration, we connected the output pin3 of the Timer and the Starter circuit to the Reset pin4 of the second 555 Timer IC. Which means as long as the output pin of the timer IC will be high, the buzzer 555 Timer IC will oscillate. Thus the output from pin3 of the Timer and Starter circuit controls the ring duration.

The 555 IC of the buzzer circuit is in astable mode which itself triggers and changes its states automatically from 'High to Low' and 'Low to High'. When a switch is pressed, then the output at pin 3 is high during the capacitor charging from a power supply VCC through resistors RV4 and RV5. This capacitor gets charged up to $2/3 V_{cc}$ so that the output becomes high through this period and the buzzer makes sound. Then the capacitor starts discharging through resistor RV5 till $1/3 V_{cc}$, and the output at pin3 becomes low during this time so the speaker gets muted and completely gets turned off when the switch opens. This process repeats until the square pulses are generated from high to low state and low to high state based on the RC time constant.

We have also connected a LED at the output of Timer IC, which will glow till the buzzer rings. We can also control the frequency of the buzzer by adjusting the value of RV5 and/or capacitor C4.

3.4 FREQUENCY GENERATOR CIRCUIT

In this circuit the 555 timer IC is being used in astable mode. In this mode, the 555 timer acts as an oscillator and the circuit does not require any external trigger to change the state of the output. The frequency of the wave can be adjusted by changing the values of two resistors- RV2 & RV3 and the capacitor C2 connected to the chip.

In this circuit, the resistor RV2 is connected between Vcc and discharge pin 7. The other resistor RV3 is connected between the discharge pin 7 and the trigger pin 2. The pin 2 and the threshold pin 6 are shorted and connected through the capacitor C2. This capacitor charges through resistor RV2 and RV3 and discharges through RV3 only. The pin1 is connected to the ground for negative biasing, and the pin 5 is connected to the ground through the capacitor, and the pin3 is used as an output.

Capacitor C2 begins charging toward VCC through resistances RV2 and RV3. Eventually, the threshold voltage exceeds $2/3 V_{CC}$, and the timer output is low. The discharge transistor Q3 saturates so that the capacitor C2 discharges through resistance RV3 with a discharging time constant.

With the discharging of capacitor, trigger voltage drops below $1/3 V_{CC}$, the timer output is high. This causes auto-transition in output from low to high and then to low and the cycle repeats.

A 80Hz frequency output is obtained from this circuit. The variable resistor RV3 is being used to change the intensity of voltage with respect to the intensity of pain.

3.5 DRIVER CIRCUIT

A typical frequency generator circuit typically gives an output only in tens of mA but the output transformer requires around hundreds of mA to operate. Therefore a transistor-based driver circuit is used to boost the current to the levels needed for operating the output transformer. When the voltage and current levels are in the correct range, the transistor acts like a high-current switch controlled by the lower current circuit. Transistor used in this driver is BD139 which primarily provides the current gain. The $2K\Omega$ resistor R7 is used along with the base of transistor. A diode is connected in reverse bias across the load to suppress the voltage spikes (back EMF) generated when the device is turned off. At high current levels, the transistor might get hot and burn out. In such cases a heat sink is used for power dissipation.

3.6 OUTPUT TRANSFORMER

The regulated output from the driver circuit is given to the transformer which step ups the voltage from 9V to 100V as per our requirement. This is a step-up transformer with 1:50 turn ratio that increases the voltage and has more secondary winding turns than that in the primary winding. The electrical output obtained is then transferred between the two electrodes and is given to the patient for the stimulation. The output voltage is in the range of 0V to 100V but the output current (100mA) is so small that there is no threat of electric shock.

3.7 ELECTRODES

The pain relief unit uses disposable electrodes to transmit the stimulation to the patient. It uses two pairs of disposable electrodes (Total- 4 electrodes).

These disposable electrodes are designed for use in various bioimpedance devices like the pain relief unit.

They are self-adhesive electrodes made with Ag/AgCl and a specific solid conductive gel optimized for diagnostic measurements execution at rest. Ag/AgCl and the solid adhesive gel provide stable and reliable measurement signals due to a highly conductive electrode-skin pairing. The special Gel ensures uniform contact impedance independently from the skin characteristics. The special construction technique allows obtaining reliable measurements, highly accurate, independently from the characteristics of the skin and from temperature and humidity conditions. The electrodes do not leave any residue on the skin and are easy to apply and remove.

4. RESULTS AND DISCUSSION

4.1 WORKING WITH PATIENT

The placement of electrodes varies as per the area of pain. In the case of:

1) Central neck pain

Position each set of electrodes on either side of the neck in the area of discomfort.

2) Shoulder pain

Position each set of electrodes above and below the pain site. Position one electrode on the neck on the same side as the painful shoulder and the other paired electrode on the painful area; position the other electrode pair in a similar way.

3) Knee pain

Position the electrodes around the knee joint above and below the pain site.

4) Lower back pain

Position the electrodes on either side of the back at the pain site. If pain is concentrated to one side position one of the paired electrodes over the site of pain next to the spine and the corresponding electrode close to the spine at the same level; position second electrode pair near the same position [3].

4.2 PRECAUTION

WHILE HANDLING THE DEVICE

- Before placing the electrode pads on the skin make sure the machine is switched off.

- Test the machine by holding the pads between the fingers and then carefully turn it on. You should feel a tingling sensation.

- Make sure the skin where the pads are applied is clean and dry and there are no cuts, grazes or areas of skin irritation.

- Place the pads either side of the pain. Use either self-adhesive pads or flexible rubber pads which should be completely covered, on the surface to be applied to the skin, with a thin layer of conductive gel. The pads should not be put within an inch (2-3 cm) of each other.

- Switch on the machine slowly and turn it up gradually until you feel a tingling sensation. The sensation needs to be quite strong but not uncomfortable. After a few minutes the sensation will start to drop away slightly. This is called accommodation. When this happens, turn the machine up slightly and then leave it for the rest of the time in use. Do not turn it up too high, as this can cause over-stimulation which may make pain worse. There should be no muscle contraction.

- At the end of the session turn the machine off and disconnect the electrodes from the machine. If you intend using the device again later there is no need to remove the electrode pads from the skin. Simply tuck the wires out of the way and carry on as normal.

- Check that the pads or tape do not irritate the skin. If the skin is red you may need to use a different type of pad, contact gel or tape.

- When you have finished using the machine for the day, carefully remove the pads from the skin and clean the skin with ordinary soap and water. Do not pull directly on the wires to remove the pads.

WHILE PLACING THE ELECTRODES

- Do not place electrode pads on broken or damaged skin.

- Do not place electrode pads over the front or side of the neck, close to eyes or in the mouth.

- Do not use over areas of reduced sensation.

- Do not use near water such as in the bath or shower.

- Do not place the electrodes near an artificial cardiac pacemaker due to risk of interference and failure of the implanted device.

4.3 RESULT

Five case reports are presented to illustrate the utilization of our device for pain relief.

Subject	Pain Area	Intensity of pain	Intensity of stimulation applied	Pain relieved or not?
Mr. Rajesh Singh	Spine	Moderate	55V	Yes
Mr. Manash Sen	Knee	High	75V	Partially

Mrs. Santana Sen	Above Elbow	Low	50V	Yes
Mr.Devdass Sharma	Lower back pain	High	70V	Partially
Mr. Probal Sen	Forearm	Moderate	65V	Yes

Table No. 1: Observations made based on working of model for settings of low and high frequencies for low and high pain respectively.

DISCUSSION: Pain relief via electrical stimulation was tested on five subjects of varying age groups. It was noticed that for moderate and low intensities of pain, a low intensity of stimulation when applied resulted in curing the pain completely. The stimulation was applied five times a week at an interval of 24 hours. For a higher intensity of pain, a higher intensity of stimulation was applied which resulted in partially curing the pain. The stimulation was applied five times a week at an interval of 24 hours. From the following results it is observed that the intensity of stimulation is directly proportional to the intensity of the pain.

4.4 APPLICATIONS AND ADVANTAGES

This device is most commonly used for people with musculoskeletal pain, such as long-term (chronic) back pain or knee joint arthritis [4]. They are also often used for pain relief in the early stages of labour as well as for non-painful conditions such as tiredness, insomnia or dementia [5]. Other less common uses include:

Dentistry: One major application of this device is in providing non-odontogenic orofacial pain relief.

Sports performance: Many athletes use this electrical muscle stimulation to build muscle, increase strength and speed recovery.

Compensating for paralysis: In paralysis blood flow of that particular area terminates therefore this technique is used as neuroprothetic to compensate for paralysis.

Control of the brain: Electrical stimulation can be used to hack the brain which is control centre of the body. Hence anything the brain controls can be manipulated with electrical stimulation such as emotions, cognitive performance and motor skills.

Alternative to drugs: It can be used as an alternative to the use of drugs either in the treatment of acute post-operative pain in the first 30 days after surgery, or for certain types of chronic, intractable pain not adequately responsive to other methods of treatment including, as appropriate, physical therapy and pharmacotherapy[6].

The advantage of our device is that it is well tolerated and largely without side-effects. It can be used alone for pain

relief or be combined with other treatments. The use of this machine allows reduction of the amount of painkilling medicines, although we need to try a few settings on the machine before finding the best one. Probably, the TENS machine available in the market are very expensive so our device can be a boon to those expensive machines.

5. CONCLUSION

We believe that electrical stimulation is a safe, simple and reusable method of pain relief involving the use of a mild electrical current. When the machine is switched on, small electrical impulses are delivered to the affected area of your body using the electrodes, which we feel as a tingling sensation. The electrical impulses can reduce the pain signals going to the spinal cord and brain, which may help relieve pain and relax muscles. Thus it is a non-invasive method that can be self-administered by the patient to manage their painful conditions. Regular use of the unit results in the following positive results: Increased concentration, reduced irritability, stress and anxiety reduction, easier physical movement, decreased use of pain-relief drugs, an improved attitude and social life, fewer trips to the doctor. The patients who used the model claimed it to be effective in reducing the intensity of pain.

REFERENCES

- [1] Walsh DM, Howe TE, Johnson MI, et al, "Transcutaneous electrical nerve stimulation for acute pain", Cochrane Library, Apr 15 '2009.
- [2] Robb K, Oxberry SG, Bennett MI, et al, "A Cochrane Systematic Review of Transcutaneous Electrical nerve Stimulation for Cancer Pain J Pain Symptom Manage", 12th September 2008
- [3] Somers DL, Clemente FR, "Transcutaneous electrical nerve stimulation for the management of neuropathic pain: the effects of frequency and electrode position on prevention of allodynia in a rat model of complex regional pain syndrome", type 2. Phys Ther 2006 May.
- [4] Rutjes AW, Nuesch E, Sterchi R, et al, "Transcutaneous electrostimulation for osteoarthritis of the knee", Cochrane Library, 2009 Oct 7 .
- [5] Dowswell T, Bedwell C, Lavender T, et al, "Transcutaneous electrical nerve stimulation (TENS) for pain relief in labour" , Cochrane Library, 2009 Apr 15.
- [6] Nnoaham KE, Kumbang J, "Transcutaneous electrical nerve stimulation (TENS) for chronic pain" , Cochrane Library, 2008 Jul 16.