

Automatic Railway Gate Control System Using RFID with High Alerting System

Rohini Jadhav¹, Harshal Patil², Prof. M. S. Wagh³

¹BE(Electronics and Telecommunication)MET's Institute Of Engineering, Nasik, India

²BE(Electronics and Telecommunication)MET's Institute Of Engineering, Nasik, India

³Professor, Dept. of Electronics and Telecommunication Engineering, MET's Institute Of Engineering, Nasik, India

Abstract – The main objective of this paper is to avoid the railway accidents happening at the level crossings. In India railway is the major mode of the transportations and it is the cheapest way for travelling. So there are more numbers of rail users. And it is not easy to stop railway anywhere to prevent accident or for any other reason. Due to that there are major drawbacks of that. At present manned system is available at level crossings. Hence, many accidents occur at such crossings, since there is no one to take care of the functioning of the railway gate when a train approaches the crossing. The objective of this paper is to manage the control system of railway gate using the microcontroller. This model includes IR sensors, RFID, LCD, buzzer, light led, motor driver and microcontroller PIC16F877A. In the automatic railway gate control system, at the level crossing the arrival of the train is detected by the IR sensor and RFID placed near to the gate. In case of RFID it detects only arrival of train. Hence, the time for which it is closed is less compared to the manually operated gates and reduces the human labor. As the entire system is automated errors occurring due to manual operation are prevented because the accuracy of automated operation is more than the manned operation.

Key Words: Automatic Railway Gate, IR Sensors, RFID, PIC 16F877A, motor driver, level crossing.

1. INTRODUCTION

Railways being the cheapest mode of transportation are preferred over all the other means. But there are so many accidents happening at the manned control level crossings. This is mainly due to the carelessness in manual operations or lack of workers. This project utilizes two pairs of IR sensor and RFID placed at the either sides of gate. Each pair of sensor consist of a transmitter and receiver, in our case light emitting diode is used as a transmitter and a p-n junction photodiode is used as receiver. It detects the arrival of the train by both sides. RFID is also used for the detection of specific train only. RFID consisting of tag and reader. Tag is given to the train and it will be read by that RFID reader only. When reader reads that tag which is placed on train then the gate will be closed. When the last carriage of train passes having tag then the gate will be opened. LCD will display information

for the road users. This process reduces the traffic and time for which users have to for long time at level crossing.

1.1 Concept

At the present, India having world's largest railway network which having manned gate control system. Over hundreds of railways running on track every day. It is definitely impossible to stop the running train at immediate in some critical situation or emergency arises. Train accidents having serious drawbacks in terms of loss of human life, injury, damage to Railway property. This model uses automatic control or operation of gate and reduces the human labors. The concept of the model is to control the railway gate using microcontroller PIC16F877A.

1.2 Objective

To avoid an unwanted accident, happening at the railway level crossing due to less awareness of drivers and poor work of gate keeper and also time saving.

2. OVERVIEW OF THE SYSTEM

2.1 Block Diagram

Fig. 1 shows over all block diagrams for railway gate control system by using microcontroller PIC 16F877A.

PIC16F877A performs some operations related to the system. IR and RFID detects the arrival the of train and they gives the signal to the microcontroller. Accordingly microcontroller gives the command to the gate driver, LCD, buzzer. If train cut the IR sensor and RFID then microcontroller gives the command to gate driver, it closed the gate and buzzer is ON. After sometime, departure of train gate is opened and buzzer is OFF. Accordingly LCD will display the message to the road users. But in case of RFID, it detects only the arrival of the train as compared to the IR sensor. So RFID is the advantageous than IR sensor for the detection of the train.

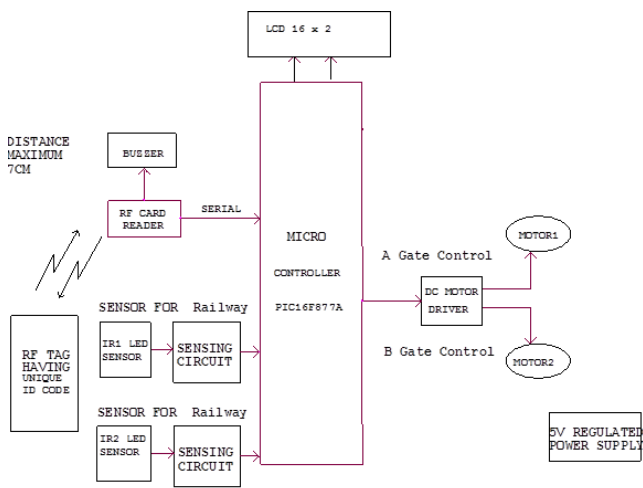

Fig-1: Block Diagram of System

2.2 Circuit Diagram

Figure 2 shows the circuit diagram of Automatic Railway Gate Control by using PIC 16F877A microcontroller. This system includes the various components for the operation of the system. This system includes two components for the detection of the train i.e. IR sensor and RFID. Initially IR emits the light. When train cuts the IR sensor then it gives the input to the microcontroller PIC16F877A, then microcontroller gives command to the gate driver so gate is closed and buzzer will be ON. When the last carriage of the train cut the second IR sensor then gate is open and buzzer is OFF. In case of RFID, the specific tag is given to the train. When that train is crosses the RFID, then that tag is read by the RFID reader. If the specific tag is read by train then and only microcontroller gives the command to the gate driver then gate is closed and buzzer is ON. On the departure of the train the gate is open and buzzer will be OFF. Accordingly the red and green led is operating. Also the LCD will display some message for the road users for informing the information about the arrival and departure of the train.

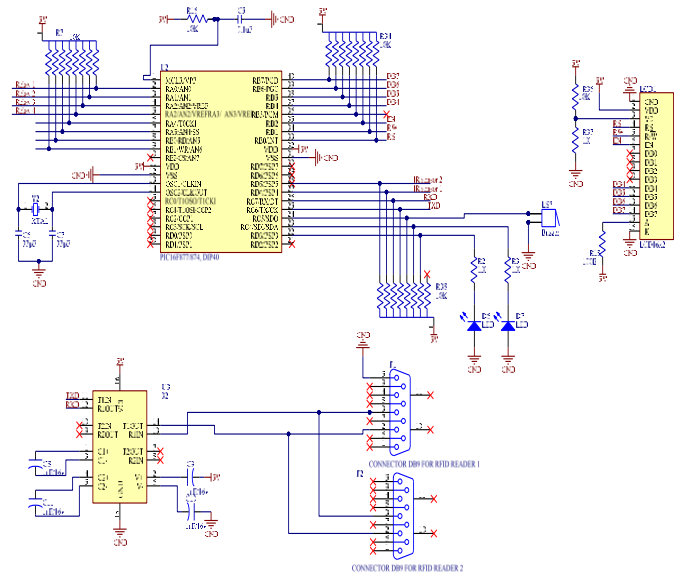

Fig-2: Circuit Diagram of System

2.3 Algorithm

- Step1: Start
- Step2: Initialize timer, LED, interrupt
- Step3: Display on LCD "WELCOME TO MET BKC IOE"
- Step4: Wait for 3sec
- Step5: Clear LCD
- Step6: Display on LCD "AUTOMATIC RAILWAY GATE CONTROL SYSTEM"
- Step7: wait for 4sec
- Step8: if IR sensor1=1 or IR sensor2=1 or RFID reader o/p=1 or RFID reader o/p=1
- Step9: if yes then display on LCD "Gate close please wait"
- Step10: Relay1=ON
Relay2=OFF
Relay3=ON
Relay4=OFF
- Step11: Delay 1sec
- Step12: Red led on, green led off
- Step13: if IR sensor1=0 or IR sensor2=0 or RFID reader o/p=0 or RFID reader2=0
- Step14: Relay1=OFF
Relay2=ON
Relay3=OFF

Relay4=ON

- Step15: Delay 1sec
- Step16: Display on LCD "Gate open please go"
- Step17: Stop.

3. CONCLUSIONS

Automatic gate control system using RFID is the efficient and easy way of reducing the accidents at the level crossings. This gives an secure model for the railway track system. Using RFID tag and reader, microcontroller PIC16F877A detects only the arrival of the specific train so only at that time gate is open and close. Due to that there is no any traffic jam and wastage of time. This will reduce the accidents in large quantity. This system can contribute a lot of benefit either to the road users or to the railway management. Since the design is completely automated it can be used in remote villages where no station master or line man is present. The RFID placed at the either side of gate so they can detect the arrival and departure of train. Now a day's automatic system occupies each and every sector of applications as it is reliable and accurate.

4. PROPOSED MODEL



Fig-3: Proposed model of system

REFERENCES

- [1] Hnin Ngwe Yee Pwint, Zaw Myo Tun, Hla Myo Tun, "Automatic Railway Gate Control System Using Microcontroller," Volume 3, Issue 5, May 2014.
- [2] Sayali R. More, Ruchira J. Raut, Rasika K. Tandel, Snehal D. Yendhe, "Intelligent Railway Crossing Gate Control with High Speed Anti-Collision Alerting System," .
- [3] Krishna, Shakshi Yadav, Nidhi, "Automatic Railway Gate Control Using Microcontroller," ISSN: 0974-6471 December 2013, Vol. 6, No. (4).
- [4] R. Boopala Venkatesh, K. Kamalanathan, "Microcontroller Based Automatic Railway Gate Control With Zero Accident," Vol. 3, Special Issue 2, March 2016.
- [5] Vikash Kumar, Prajit Paul, Nishant kumar, Pratik kumar Sinha, Sumant Kumar Mahato, "Automatic Railway Gate Controller with High Speed Alerting System," Vol. 4, Issue 5, May 2015.