

Design and Development of Solar Panel Inverter with MPPT

Vaishali T. Tekade¹, Mrunali R. Kude², Bharat D. Deore³, Priyanka V. Ahire⁴

^{1,2} Student, Department of E&TC Engineering, SIEM, Nasik, Maharashtra, India

^{3,4} Assistant Professor, Department of E&TC Engineering, SIEM, Nasik, Maharashtra, India

Abstract - The Sun, Wind, Waves and geothermal heat are free source of energy they can use this free and unlimited energy source to work the electrical appliances. They are permanent or self renewing. Solar energy is rapidly reducing an important means of expanding renewable energy resources. A great increase of photovoltaic (PV) power in now a day's generators establishment has increase due to efficiency of solar cells as well as the improvements of manufacturing technology of solar panels. We can receive the maximum radiation due to the movement of solar panel according to the sun direction. Solar panels are used to convert light energy into electrical energy. Capture the maximum power from the sun light in order to produce maximum power from the inverter. An inverter is an electrical or electromechanical device. This device will convert direct current (DC) to alternating current (AC). Energy from the sun is the best option for electricity generation as it is available all over and free to harness.

Key Words: Solar Panel, Inverter, motor, Sensor, Solar tracking system.

1. INTRODUCTION

The single solar cell is very less, hence the solar cells are connected in series to form PV module. To from photovoltaic array the PV modules are connected in series and parallel form. While fossil fuel exhaustion and greenhouse effects are widely important around the world, therefore the problem can be solved by applying a long term for the problem which is accrued. Due to different panel shadowing effect and orientations condition PV panels often work in mismatching condition. To each PV panel for extracting it is maximum power. Maximum power point tracking (MPPT) converters are attached. [3]

The solar tracking system automatically adjusts the PV panel based on the given position of tilt times with respect to the natural position of the Sun at different times. Microcontroller (PIC16F877A) through dc geared motor controlled that the tracking. Then microcontroller (PIC16F877A) sends a high output to the driver which drives the DC motors connected to the panel. And at This mode the controller will continuously reads system. If it matches with the values, the corresponding and tilt angle will be sent to the microcontroller (PIC16F877A) which will make the motor to rotate the solar panel using driver. The tilt angel and panel rotation will be fixed in the program that is given

to the micro controller. PIC PIC microcontroller is a RISC based Architecture. It is low cost and is used for real time application [2]. The size and cost of the PIC microcontroller are less as compare to PLC and ARM7. The 14 MHz crystal oscillator is used to provide the required clock signals. [6][2] Advantages of PIC microcontroller [6][2]

- Supports up to 32 Endpoints. (16 bidirectional)
- On-Chip USB Transceiver with On-Chip Voltage Regulator.
- Four Timer modules (Timer0 to Timer3).
- High Performance RISC CPU Synchronous Serial Port (SSP) with SPI (Master mode) and I2C™ (Master/Slave)

2. SYSTEM IMPLIMENTATION

The sun rays fall on the solar cell in some particular direction then only we get maximum output, The solar cells output depends on the intensity of sunlight and the angle of incidence. Hence the solar cells are rotated in the direction of sun position where we get maximum efficiency. solar tracker is the best for receiving maximum radiation. According to the movement of sun by moving the solar panel we can always receive the maximum radiation. Solar panels are used convert into light energy into electrical energy. Efficient Solar Power generation System using moving panel is a efficient power generating system using sun light. Total four sensor are used two sensors is E-W and other two sensor is N-S directions to sense the direction of maximum intensity of light.

The difference between to the outputs of the sensors is given to the microcontroller (PIC18F877A). Microcontroller is used to process the input voltage from the parallel circuit and control the direction in which the motor has to be rotated so that it will receive maximum intensity of light from the sun. The power generated for this process is then stored in a lead acid battery. The proposed a system provides a indication of their relative angle to the sun by comparing with predefined measured readings. By using this method, sufficiently perpendicular angle the solar tracker was successfully maintained a solar array to the Sun.

2.1. Flow chart

The flowchart is so drawn that it is self-explanatory and gives the complete idea of how computer sequentially does the different operations to measurement and control. The flow chart of motor position control system for solar tracking application is shown in Fig.1.

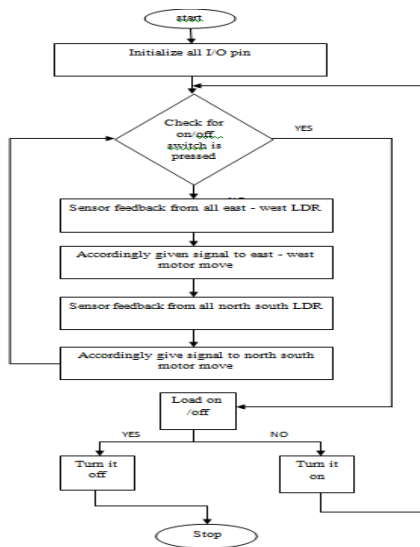

Fig1: Flow chart

2.2 Working Block Diagram

A LDR sensor senses max solar power which is being given to the Micro controller through the Analog to digital converter which digitizes the LDR output.

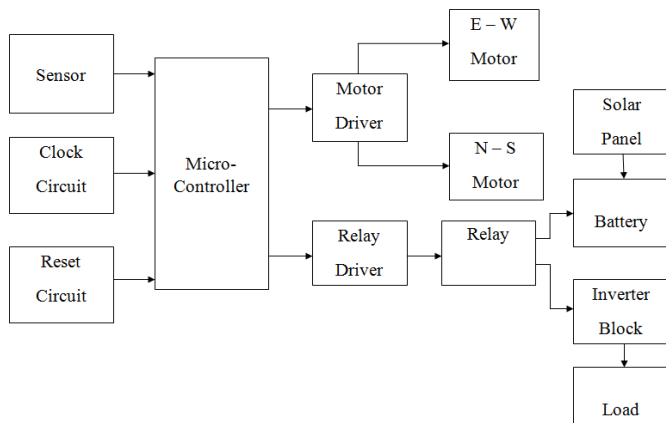

Fig.2: System Block diagram

The PIC controller receives analog input from panel. The maximum voltage which can be obtained from solar cell is set as reference voltage in micro controller. The output of ADC is same to the reference voltage then motor keeps the solar panel in same direction. The solar cell captures the sun's rays and gives the analog output to the ADC. The solar cells are rotated in the direction of sun position where we get maximum efficiency. The over all bloc diagram is shown in fig 2. Solar tracker is the best for receiving maximum radiation. According to the movement of sun by moving the solar panel we can always receive the maximum radiation. Solar panels are used convert into light energy into electrical energy. This energy are stored in battery is DC current then connect the inverter is main function are DC to AC convert.

2.3. Hardware Requirements

2.3.1. Sensor

A sensor is an object whose meaning is to detect events or changes in its environment, and then provide a compatible output. A sensor is a type of transducer; sensors may provide various types of output but typically use electrical or optical signals. It consists of a four LDR sensor senses max solar power which is being given to the Micro controller through the Analog to digital converter which digitizes the LDR output. Controllers then take the decision according to then algorithm and skew the panel towards the direction of the maximum energy given by LDR with the help of Motor. The Motor is used to rotate the LDR to sense the maximum solar power.

2.3.2. Motor

A motor driver is an integrated circuit which is usually used to control motors in automatically. Dc geared motor are not directly interface to microcontrollers. This project are two motor is used then one motor is north to south rotate and second motor is west to east rotate. Motor driver act as an interface between microprocessors in dc geared motor through solar panel. A motor driver is a little current amplifier the function of motor drivers is to take a low-current control signal and then turn it into a higher-current signal that can drive a motor.

2.3.3. Inverter

Electrical power is usually transmitted and used in the form of alternating current AC. Some kinds of electrical generation and storage devices produce direct current, example being PV modules and batteries. An inverter is power electronic apparatus which converts direct current DC to alternating current AC, allowing the DC power from these generators to be used with ordinary AC appliances, and mixed with the existing electrical grid.

2.3.4. PCB Design

Single sided copper PCB is used for implementation of electrical circuits. For preparation of lay out and simulation PROTEUS can be used. While designing of printed circuit board some precaution must be taken [9] to avoid faults in printed circuit board design.

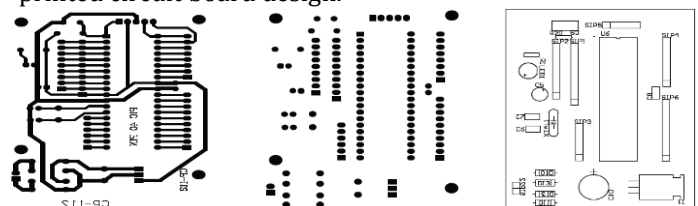

Fig.3: PCB layouts

2.4 Maximum Power Point Tracking Panel

MPPT is maximum power point tracking panel, this is where the panel are on a mount that follows the sun. These optimize output by following the sun across the sky for maximum sunlight. These typically give you about a 15% increase in winter and up to a 35% increase in summer. They take DC input from the solar panel change to high frequency AC and convert it back down to different DC voltage and current to exactly match the panels to the batteries.[3][7]

2.5 Solar Panel working

Photovoltaic array generates a form of renewable electricity particularly useful in situations where electrical power from the grid is not available such as in remote area power systems.

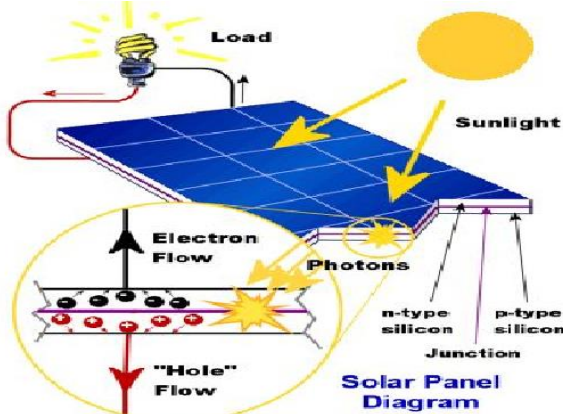

Fig.4: Solar panel working representation

Figure 4 shows Solar panel working representation. A solar cell sometimes called a photovoltaic cell. It is a device that converts light energy into electrical energy. The PIC controller receives analog input from panel. The maximum voltage which can be obtained from solar cell is set as reference voltage in microcontroller (PIC16F877A). The Panel output current and voltage is compared with the reference current and voltage accordingly controller gives signal to the DC geared motor. The output of ADC is same to the reference voltage then DC geared motor keeps the solar panel in same direction. The solar cell captures the sun's rays and gives the analog output to the ADC.[5]

3. RESULTS DISCUSSION

3.1. Maximum Power Point Tracking System

Snap shots of implemented tracking system is shown in Fig. 5.

Power Point tracking system are used four LDR sensors, when two sensors is sense then motor is rotate in E-W direction and other two sensors worked then rotate in N-S direction. This system advantage is maximum intensity of light and increase the panel efficiency.

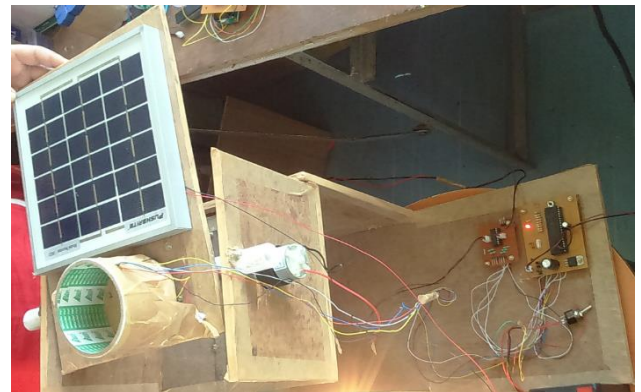

Fig5: Tracking system

3.2. Solar Panel Inverter Model

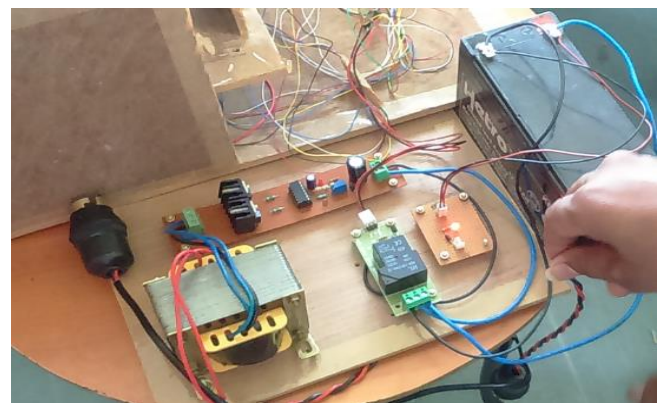

Fig6: Inverter model

3.3. Experimental Model with MPPT

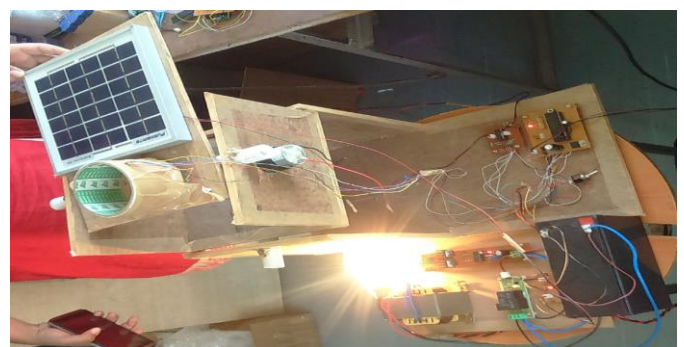

Fig7: maximum power point tracking panel output

In further work we are working to introduce this system with LAB VIEW software. Lab VIEW is also called system design platform and development environment for a visual programming language. Lab VIEW is an interactive program development and execution system in which one creates program using graphical notation.[4] GSM modem can also be

used to operate the operation of solar panel to make system wireless and integrative. Quad-band intelligent GSM/GPRS modem suitable for long duration data transmission. [8]

4. CONCLUSION

In the above paper we have given details regarding implementation of solar power tracing system. The interest of solar energy has become more important due to surging oil prices and environmental effect. In many remote or under develop areas, direct access to an electric grid is impossible and a photovoltaic inverter system would make life much simpler and has become convenient. The proposed system provides a variable indication of their relative angle to the sun by comparing with predefined measured readings. This project is main part of solar panels are used convert into light energy into electrical energy. This energy is stored in battery then the energy is provide to inverter is main function are DC to AC convert and inverter output is bulb or any component to run in electricity. The solar panel is also used in solar tracking this system to increase in panel efficiency in percent. This energy is essential for life time on Earth. It is a renewable resource that is clean, economical, and less pollution compared to other resources and energy. The proposed design is having an low power consumption, low cost and high accuracy.

ACKNOWLEDGEMENT

We would like to thanks all people who have helped us directly or indirectly for the completion of this paper work. We express our truly gratitude towards Prof. S. R. Kurkute for guiding us to understand the work conceptually. Prof. B. D. Deore for his constant incitement to complete this project work on "SOLAR PANEL INVERTER WITH MPPT". We are also expressing our thanks to Dr. D. P. Patil head of the department of Electronic and Tele-communication Engineering for providing important information and required resources. With deep sense of gratitude we thanks to our Principal Dr. M. P. Ray and Management of the Sandip Foundation for providing all necessary facilities and their constant encouragement and support.

REFERENCES

- [1] D. Kornack and P. Rakic, "Cell Proliferation without Neurogenesis in Adult Primate Neocortex," *Science*, vol. 294, Dec. 2001, pp. 2127-2130, doi:10.1126/science.1065467.
- [2] S. R. Kurkute, C.Medhe, A.Revgade, A.Kshirsagar, "Automatic Ration Distribution System -A Review". Intl. Conf. Proceedings of the 10th INDIACom; INDIACom-2016; IEEE Conference ID: 37465 2016 on Computing for Sustainable Global Development, 2016.
- [3] Kumaresh. V, Mridul Malhotra, Ramakrishna N and saravanaPabhu.R , "Literature Review on Solar MPPT

Systems," *Advance in Electronic and Electric Engineering*.ISSN 2231-1297, Volume 4, Number 3 (2014), pp. 285-296.

- [4] Prof. Swapnil R. Kurkute, Ms.Arbutj Komal Promod, Ms. Dargude Chaitanya Rangnath, Ms.Dholi Komal Dattu, "Laboratory Virtual Instrument Engineering Workbench (LABVIEW)", *International Journal of Modern Embedded System (IJMES)*, ISSN: 2320-9003(Online), Volume No.-5, Issue No.-1, February, 2017, Page No-17-20
- [5] Jeng-Nan Juang and R. Radharamanan, "Design of a Solar Tracking System for Renewable Energy", *Proceedings of 2014 Zone 1 Conference of the American Society for Engineering Education*, 2014.
- [6] S. R. Kurkute, C.Medhe, A.Revgade, A.Kshirsagar,D.P.Patil "Automatic Ration Distribution System -A Review". Intl. Conf. WPMC 2015
- [7] Prashant Meshram and U.B.Mujumdar, " Design and Development of MPPT based Converter for Efficient Solar Power Conversion," *2nd National Conference on Innovative Paradigms in Engineering & Technology 2013*, pp. 35-39.
- [8] Prof. S. R. Kurkute, Gopal Girase, Prashant Patil, " Automatic Energy Meter Reading System Using GSM Technology" *International Journal of Innovative Resurch In Electrical,Electronics,Instumentation And Control Engineering* ISSN: 2321-2004 (Online) Volume No.-4, Issue No.-3, IF- 4.855
- [9] Prof. Swapnil R. Kurkute, Ms. Kakrale Priti Nivrutti, Ms. Kale Shraddha Sunil, Ms.Kudav Aboli Santosh, "PCB Quality Monitoring", *International Journal of Modern Embedded System (IJMES)*, ISSN: 2320-9003(Online), Volume No.-5, Issue No.-1, February, 2017, Page No-13-16

BIOGRAPHIES

| | |
|---|---|
|  | "Vaishali Tekade –Pursuing BE in E&TC Engineering, SIEM, Nasik,." |
|  | "Mrunali Kude –Pursuing BE in E&TC Engineering, SIEM, Nasik,." |
|  | "Prof. Bharat D. Deore –Received BE in Electronics and Telecommunication Engineering and ME in Electronics & Telecommunication. Vidyalkar Institute of Technology, Wadala, Mumbai, completed in 2014." |
|  | "Prof. Priyanka V. Ahire –Received BE in Electronics and Telecommunication Engineering and ME in Electronics & Telecommunication, Sir Visvesvaraya Institute of Technology, Chincholi, Nasik, completed in 2015." |