

Study of Transformer Oil Filtration Machine

Shreya Salvi¹, A.P.Paranjape²,

¹M.E. student, Dept. of Electrical Power System, P.E.S. College of Engineering, Aurangabad, Maharashtra, India

²Professor, Dept. of Electrical Power System, P.E.S. College of Engineering, Aurangabad, Maharashtra, India

Abstract - Nearly all load bearing transformers in electric power systems around the world are filled with insulating oil i.e. transformer oil. Insulating oil plays a major role in the transformer, acting as insulating medium and as coolant. Transformers in electric power distribution and transmission systems are expected to function reliably and efficiently for uninterrupted power supply and to do this the quality of the transformer oil must be high. To maintain high quality of the transformer oil, purification of transformer oil by high vacuum transformer oil filtration machine should be conducted regularly. In this paper, we will study about the transformer oil filtration machine and how it purifies the contaminated transformer oil.

Key Words: Degasification, Insulating oil, Moisture, Purification, Transformer.

1. INTRODUCTION

Transformer is one of the most important and costly components of power system. Extreme reliability is demanded of electric power system, and even though the failure risk of a transformer is small, when failures occur, they lead to high repair costs, long downtime and possible safety risks. Moreover, transformers are too expensive to replace regularly and must be properly maintained to maximize their life expectancy. So for getting high performance and long functional life of the transformer, it is desired to perform various maintenance activities. Purification of transformer oil is one of these maintenance activities, since transformer's life mainly depends on its insulating oil i.e. transformer oil. To purify transformer oil, high vacuum transformer oil filtration machine is used. It consists of inlet pump, filters, heaters, ionic reaction column, degassing and dehydration chamber, discharge pump, vacuum pumps etc. In this paper, we will study about the transformer oil filtration machine and how it works to purify the contaminated transformer oil.

2. Insulating Oil

Primarily, two kinds of basic insulation materials are widely used in the transformer, including the liquid insulation material such as insulating oil i.e. transformer oil and solid insulation material such as insulation paper. The widespread use of dielectric liquids for insulation and cooling is due to their greater electrical breakdown strength and thermal conductivity than gaseous insulators, while their

ability to conform to complex geometries and self-heal means that they are often of more practical use than solid insulators. Transformer oil is highly refined mineral oil that is stable at high temperatures and has excellent electrical insulating properties. It is normally obtained by fractional distillation and subsequent treatment of crude petroleum. Hence why this oil is also known as mineral insulating oil. Transformer oil provides part of the electrical insulation between internal live parts in the transformer. It also helps cool the transformer i.e. it acts as a coolant.

Causes of contamination of transformer oil are electrical disturbances and thermal decomposition. Various contaminants like moisture, sludge, dissolved gases etc. Present in the transformer oil reduces the breakdown strength of transformer oil, promotes local heating, increases the electrical conductivity and decreases the electrical and mechanical strength of the insulation system. The contaminants also decelerates the transformer efficiency. The failure of liquid insulation can cause catastrophic damage not only to the power equipment, but also to the surrounding environment. Furthermore, failure often leads to major operational disruption and financial loss. Purification of the transformer oil by high vacuum transformer oil filtration machine removes all these contaminants from transformer oil. The dielectric strength of fresh, thoroughly purified (filtered, degassed, dehumidified) insulating oil is several times higher than that of aged, contaminated insulating oil. Better the insulation of the transformer, longer the life of the transformer and lesser the breakdown of the transformer which eventually results in good returns on investment of the transformer asset and uninterrupted power supply.

3. High Vacuum Transformer Oil Filtration Machine

Transformer oil when untreated will normally contain 50 to 60 ppm (parts per million) of water and also 10% to 12% of air by volume at saturation. In order to bring the oil in required standards, it has to be filtered to remove moisture, dissolved gases, ferrous and non-ferrous suspended particles so as to achieve the required properties of transformer oil.

The high vacuum transformer oil filtration machine treats the transformer oil & switchgear oil by first heating it and then passing it through specially designed filter and then subjecting it to high vacuum treatment which dehydrates and degasifies the oil to the standard specifications after completion of the process.



Fig - 1: High Vacuum Transformer Oil Filtration Machine

Fig. – 1 shows the high vacuum transformer oil filtration machine. Transformer oil filtration machines are available in various ratings starting from 100 LPH (liters per hour) to 16,000 LPH. The filtration machine is either stationary type or mobile type. The screw jacks are provided for relieving pressure on wheels at stationary conditions. It is weather proofed and suitable for outdoor use. The equipment is enclosed and protected against climatic conditions. All the components have adequate strength and rigidity to withstand the normal conditions of handling transport and usage. The plant is suitable for operation on 415 volts, three phase, 4 wire, 50 Hz, A.C. Supply.

The high vacuum transformer oil filtration machine consists of:

3.1 Inlet Pump

Inlet pump pumps the contaminated oil from transformer to oil filtration machine. It is thoroughly tested for vacuum and is suitable for continuous trouble free operation. It is provided with an automatic protection against over-pressure build-up. Interlocking arrangement is provided in between the oil inlet pump and the heater so that heater cannot be energized unless inlet pump is on. Interlocking arrangement is provided in the oil filtration machine between the inlet pump and high level float switch (located into degassing and dehydration chamber) to avoid excessive rise of oil in the degassing and dehydration chamber.

3.2 Heaters

The first step in this serial process is to raise the oil temperature to a desired level, generally upto 65 Degree Celsius. This aids to give the oil latent heat which later aids to dissociate the moisture and gases from oil in the degassing and dehydration chamber. Additionally the viscosity of the oil drops which aids in better filtration to some extent. Heaters are provided in protection tubes to avoid localized overheating, hot spot & breaking oil. Heaters are thermostatically controlled. Heater elements consists of nichrome / kanthal wire filament, inserted in refractory

formers which are located in protection tubes. Heater tank is adequately thermally insulated to minimize loss of heat. One suitable pressure relief valve is provided on the heater chamber to prevent any pressure rise above the acceptable limit.

3.3 Filtration System

3.3.1 Preliminary Filter

The main function of this filter is to prevent any damage to the inlet pump. It have strainers capable of retaining all particles above 1 mm size and also magnetic particles. Incoming oil is passed through this filter. It is possible to clean the strainer without dismantling the filter from the pipeline.

3.3.2 Filter Press

Filter press shall consist of filters held between metallic discs. It is suitable for removal of particles bigger than 50 microns. This is useful for removal of sludge content in the used oil.

3.3.3 Cartridge Filter

Non-hygroscopic throw away type cartridge filters of one micron rating is provided. This cartridge elements have large dust holding capacity. The replacement of cartridge elements is very easy and can be done without any special tools. Compound (pressure / vacuum) gauge is provided on filter vessel for inlet pressure indication in order to ascertain condition of cartridge elements. Aeration is provided on the filter vessel to aerate the vessel during draining. The cartridge type filter facilitates to achieve desired value of particle size in micron.

3.4 Ionic Reaction Column

An ionic reaction column is provided in high vacuum transformer oil filtration machine to reduce the acidity in the oil. It is an optional component in high vacuum transformer oil filtration machine which is provided if the customer demands it.

3.5 Degassing and Dehydration Chamber

The third step in the oil filtration machine is dehydration and degasification of the transformer oil. In degassing and dehydration chamber, dissolved gases and moisture from the transformer oil is removed. It has mild steel welded construction. The chamber is able to withstand the vacuum to which it is subjected. Efficiently spread Raschig rings are placed in the degassing and dehydration chamber. Raschig rings are pieces of tubes which are approximately equal in length and diameter. Usually, Copper or Aluminum Raschig rings are used in high vacuum transformer oil filtration machine. The surface area offered by the Raschig rings is sufficient to form a thin film of oil and facilitates removal of dissolved gases and moisture at the rated flow rate of oil. A

sight glass with illuminating lamp is provided for observation of oil flow in the degassing and dehydration chamber. One float switch on the degassing and dehydration chamber is provided for preventing excess rise of oil level and is electrically interlocked with the inlet pump. Another float switch to control the low level of the oil in degassing and dehydration chamber is provided and it is electrically interlocked with the discharge pump. Two or three stages are separated by a siphon seal. One airing valve is provided for airing the degassing and dehydration chamber.

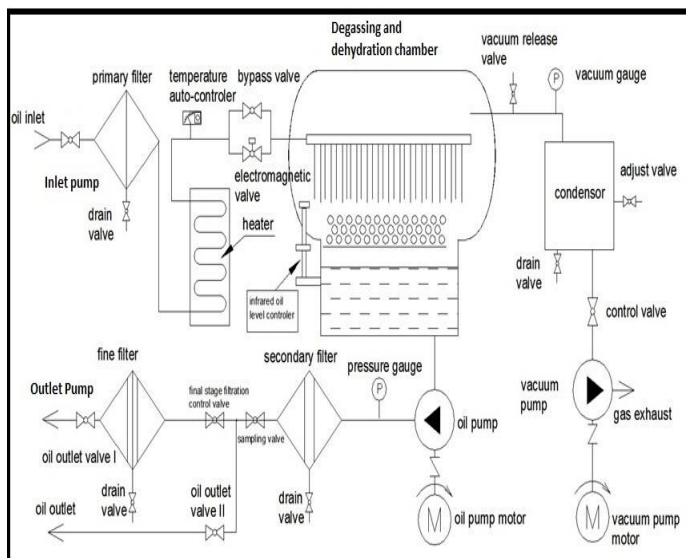

Fig -2: Circuit Diagram of High Vacuum Transformer Oil Filtration Machine

3.6 Vacuum Pumping System

Vacuum pumps are provided for evacuation of degassing and dehydration chamber. These pumps are of imported make.

3.7 Discharge Pump

A discharge pump is provided in high vacuum transformer oil filtration machine for sucking oil from the degassing and dehydration chamber held under vacuum. They are fully tested for pressure and vacuum leak rate. Interlocking arrangement are provided between low level float switch (located in degassing and dehydration chamber) and discharge pump to prevent dry running of discharge pump.

3.8 Oil Hoses

Two nitrile rubber hoses with flanged end connection on both sides are provided, one for oil inlet & one for oil outlet. They are capable of handling the transformer oil at 100 Degrees Celsius (maximum) and vacuum.



Fig -3: Transformer Oil Before and After Filtration

After three to five passes in the high vacuum transformer oil filtration machine, the transformer oil gets purified. Fig. 3 shows the transformer oil before and after filtration from high vacuum transformer oil filtration machine. The brown colored oil is unfiltered oil whereas pale yellow colored oil is filtered (or purified) oil. Fig. 2 shows the circuit diagram of high vacuum transformer oil filtration machine. The dielectric properties of oil may vary depending upon the content of gas, moisture, suspended particles and contaminants. Even new oil absorbs gas and moisture while in storage. Therefore sometimes oil is to be treated before use. Degassing and dehumidification of oil is also necessary periodically, during use, because dielectric properties will be affected due to the absorption of gas and moisture in service at different weather conditions.

4. CONCLUSIONS

This paper is related to the study of high vacuum transformer oil filtration machine and how its various components remove the contaminants like moisture, dissolved gases, sludge contents etc. from the transformer oil. Regular purification of transformer oil maintains its high quality, thus assures long and consistent results from the transformer.

REFERENCES

- [1] B. L. Theraja and A. K. Theraja, "Textbook of Electrical Technology", Vol. 2, 1st multi-coloured edition., S. Chand & Company Ltd., 2010.
- [2] The electrical4u.com [online] Available : <https://www.electrical4u.com/transformer-insulating-oil-and-types-of-transformer-oil/>
- [3] IEEE : A. Raymon and R. Karthik, "Reclaiming Aged Transformer Oil with Activated Bentonite and

Enhancing Reclaimed and Fresh Transformer Oils with Antioxidants”,IEEE Transactions on Dielectrics and Electrical Insulation,Vol. 22, No.2; February 2015

- [4] IEEE : Junhao Li, Quanwei Hu, Xuefeng Zhao, Xiu Yao, Yongfen Luo, and Yanming Li, “Partial-Discharge Characteristics of Free Spherical Conducting Particles Under AC Condition in Transformer Oil”,IEEE Transactions on power delivery,Vol. 26, No.2; April 2011
- [5] T.O.Rouse “Mineral Insulating Oil in Transformer” IEEE Electrical Insulation Magazine;1998
- [6] The Nach Engineering Pvt. Ltd. website [online] Available : <http://nachengg.net/transformer-oil-purification-process>