

ENHANCEMENT OF VAPOUR COMPRESSION REFRIGERATION SYSTEM USING NANOFLUIDS

V.K. Dongare¹, Jyoti Kadam², Amruta Samel³, Rupali Pawar⁴, Sampada Sarvankar⁵

¹ Assistant professor, Department of Mechanical Engineering, Rajendra Mane College of Engineering & Technology, Ratnagiri - 415804, Maharashtra, India.

² Under Graduate, Department of Mechanical Engineering, Rajendra Mane College of Engineering & Technology, Ratnagiri - 415804, Maharashtra, India.

³ Under Graduate, Department of Mechanical Engineering, Rajendra Mane College of Engineering & Technology, Ratnagiri - 415804, Maharashtra, India.

⁴ Under Graduate, Department of Mechanical Engineering, Rajendra Mane College of Engineering & Technology, Ratnagiri - 415804, Maharashtra, India.

⁵ Under Graduate, Department of Mechanical Engineering, Rajendra Mane College of Engineering & Technology, Ratnagiri - 415804, Maharashtra, India.

Abstract - Now days, refrigeration systems have become one of the most important systems for people's daily lives. So the use of refrigerants is increasing day by day. In past five years, nano-refrigerant has become the input for large number of experimental and vapours compression systems because of shortage of energy and environmental considerations. The conventional refrigerants have major role in global warming and depletion of the ozone layer. By adding nanoparticles with refrigerants the coefficient of performance, heat transfer rate and thermal conductivity will increased. Because of that power consumption rate will be reduced. This paper compares coefficient of performance of refrigeration system with nanorefrigerants and without nanorefrigerants such as R134a, Mo49 and blend of R290 and R600a.

Key Words: VCRS, refrigerants, nanoparticles, COP, etc...

1.INTRODUCTION

In present situation, most of the domestic vapour compression refrigerators are equipped with R134a due to its thermodynamic properties. However, it is known that it has a higher global warming potential. The ozone depleting potential (ODP) and global warming potential (GWP) have become the most important criteria in the development of new refrigerants apart from the refrigerants CFCs due to their contribution to ozone layer depletion and global warming. In spite of their high GWP, alternatives to refrigerants CFCs and HCFCs such as hydrofluorocarbon (HFC) refrigerants with the zero ODP and hydro carbon refrigerants (HC) have been preferred for Use in many industrial and domestic applications.

The HFC refrigerants are considered as one of the six target greenhouse gases under Kyoto protocol of United Nations frame work convention on climate change (UNFCCC) in 1997. So it is necessary to find alternative refrigerant to

R134a. Past studies shows that blend of R290 (propane) and R600a (isobutane) can comfortably replace R134a with different proportions. In addition to this blend refrigerant has got optimum proportion of 50% from R290 and 50% R600a. This shows that Conventional refrigerants with high global warming potential can be replaced by eco-friendly refrigerants.

However in order to improve the system performance use of nanofluids is preferable. Nanofluids are a relatively new class of fluids which consist of a base fluid with nano-sized particles (1-100 nm) suspended within them. These particles, generally a metal or metal oxide, increase conduction and convection coefficients, allowing for more heat transfer out of the coolant. Nanofluids are defined as suspension of nano-particles in a base fluid. Many researchers have explored need for improvement in performance of VCRS by using nanofluids. Hence this research work is aimed at performance analysis of VCRS by using eco-friendly nanofluid refrigerants with varying proportions of nano particles in base refrigerant.

1.1 Refrigerants

A refrigerant is a substance or a mixture usually a fluid used in refrigeration cycle. The ideal refrigerant would have favorable thermodynamic properties such as non corrosive, non flammable, and non toxic. There are two types of refrigerants primary and secondary refrigerants.

R134a(Tetrafluoroethane) having a GWP of 1430 and boiling point -26.1°C. Blend of R290(Propane) and R600a(Isobutane) having GWP 20 and boiling point -32.8°C and -11.73°C respectively. Mo49 having GWP 2100 and boiling point -33.40°C. All the refrigerants having zero ODP. Mo49 is the replacement of R12(Dichlorofluoromethane).

According to the Montreal protocol which is an international treaty design to protect ozone layer, the R12 is banned.[1]

1.2 Nanoparticles

Nanoparticles are the simplest form of structures with sizes in the nanometer range. In principle any collection of atoms bonded together with a structural radius of < 100 nm can be considered as nanoparticle. These can include fullerenes, metal clusters (agglomerates of metal atoms), large molecules, such as proteins and even hydrogen-bonded assemblies of water molecules, which exist in water at ambient temperatures. Different nano particles (Cu, Al₂O₃, CuO and TiO₂) were studied for different volume fraction and particle diameters. Simulation results have shown that, for a given refrigerating capacity, evaporator area and refrigerant-side pressure drop are reduced when: (I) the volume fraction of nanoparticles increase; (ii) the diameter of nanoparticles decrease.

Cuo(Copper oxide) is a brownish black powder, 40nm with 99% purity & 6.3-6.49gm/cm³ density. Having 1326°C melting point. It has peculiar chemical and physical properties such as quantum size effect, volume effect, optical absorption, high thermal resistance, etc. Al₂O₃(Aluminium oxide) is a whitish powder, 40nm with 99% purity & 2.9gm/cm³ density. Having 2017 °C melting point.[2] & [3]

2. EXPERIMENTAL SET UP

The process of refrigeration occurs in a system which encompasses of a compressor, a condenser, expansion device and an evaporator. VCERS system functions based on reversed Bryton cycle. The VCERS system consists of four main components which are compressor, condenser, expansion device and evaporator. Fig.1 shows the schematic diagram of the VCERS system. Compressor is used to compress the low temperature and pressure refrigerant from the evaporator to high temperature and pressure. After compression the high temperature and pressure refrigerant is discharged into the condenser through the delivery or discharge valve.

The Condenser consists of coils of pipe in which the high temperature and pressure refrigerant is cooled and condensed. The refrigerant, which passing through the condenser, gives up its latent heat to the surrounding condensing medium which is normally air or water. The condensed liquid refrigerant from the condenser is stored in the vessel known as receiver from where it is supplied to evaporator through the expansion valve (i.e. capillary) or refrigerant control valve. The function of the expansion valve is to allow the liquid refrigerant under high temperature and pressure to pass at a controlled rate after reducing its temperature and pressure. Some of the liquid refrigerant evaporates as it passes through the expansion valve, but the greater portion is vaporized in the evaporator at low

temperature and pressure.

Next it travels to the evaporator. An Evaporator consists of coils of pipes in which the liquid-vapour refrigerant at low temperature and pressure is evaporated and changed into vapor refrigerant at low pressure and temperature. In evaporating, the liquid vapor refrigerant absorbs its latent heat of vaporization from the medium (water) which is to be cooled. The performance of the water cooler system is to be evaluated by using experimental methods which is carried out by using the specially developed test rig. The test rig can be modified and upgraded if required. The work explains some of the technical modification and evaluation of the refrigeration system under varying load condition. The refrigeration system used to test the concept has a low pressure with single hermetically sealed compressor.

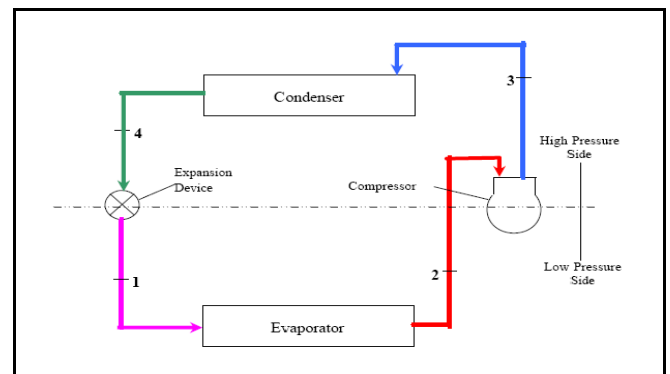

Fig.1: VCR cycle



Fig.2: Water Cooler Test Rig

2. NANOFUIDS

2.1 Nanofluids Preparation

Nanoparticles are not directly inserted into refrigeration system, it is necessary that nanoparticles should be properly mixed in lubricant oil. Basically two methods for nanoparticles insertion such as one step method and two step method. In this research select two step method. In this research work the lubricant oil used which is SUNIZO 3GS oil. For CuO and Al₂O₃ of 300mg are mixed in lubricant oil for R134a and Mo49 as per refrigerant quantity. For refrigerant blend of R290 and 600a 120 mg of nanoparticles are added. For proper mixing of nanoparticles with lubricant oil need to stir for 2-3 hrs. After total mixing or when nanoparticles are totally dispersed into lubricating oil they are inserted into refrigeration system through compressor.

2.2 Nanofluids Insertion

Nanoparticles are inserted through the compressor. First the compressor is dismantled from a system to remove oil from it and after that it will be assemble with the system by welding process. Gas charging and vacuuming process is done by vacuum pump. After gas charging the refrigerant is charged in a system. When refrigerant is get fully charged in system then through purging line of compressor the nanofluid inserted by using hose pipe.

3. CALCULATIONS

3.1 Specification-

P1 = Evaporator Pressure

P2 = Condenser Pressure

T1 = Evaporator Outlet Temperature

T2 = Condenser Inlet Temperature

T3 = Condenser Outlet Temperature

T4 = Evaporator Inlet Temperature

T5 = Water Temperature in Evaporator

h1 = Enthalpy at Evaporator Outlet Temperature

h2 = Enthalpy at Condenser Inlet Temperature

h3 = h4 = Enthalpy at Condenser Outlet Temperature

R. E. = Refrigeration Effect

C.W. = Compressor Work

COP = Coefficient of performance

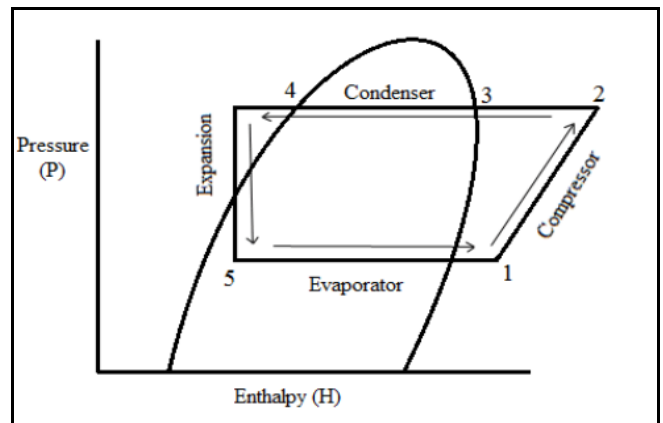

Fig.3: p-h chart

3.2 Observation Tables -

All the observations are took after 30 minutes at load condition-

3.2.1. Trial on R134a without nanoparticles

1) **Table-1:** Observation table for R134a without nanoparticles

Pressure (bar)		Temperature (°C)					COP
P ₁	P ₂	T ₁	T ₂	T ₃	T ₄	T ₅	
1.56	9.51	26	51	28	11	17	10.08

3.2.2. Trial on R134a with CuO nanoparticles

Table-2: Observation table for R134a with CuO

P ₁ (bar)	P ₂ (bar)	T ₁ (°C)	T ₂ (°C)	T ₃ (°C)	T ₄ (°C)	R.E.	C.W.	COP
1.49	8.97	17	48	33	20	172.9	12.4	13.85

From p-h chart

$$h1 = 416.64 \text{ kJ/kg}$$

$$h2 = 429.12 \text{ kJ/kg}$$

$$hf3 = h4 = 243.68 \text{ kJ/kg}$$

$$\text{COP} = (h_1 - h_4) / (h_2 - h_1)$$

$$\text{COP} = (416.64 - 243.68) / (429.12 - 416.64)$$

$$\text{COP} = 13.85$$

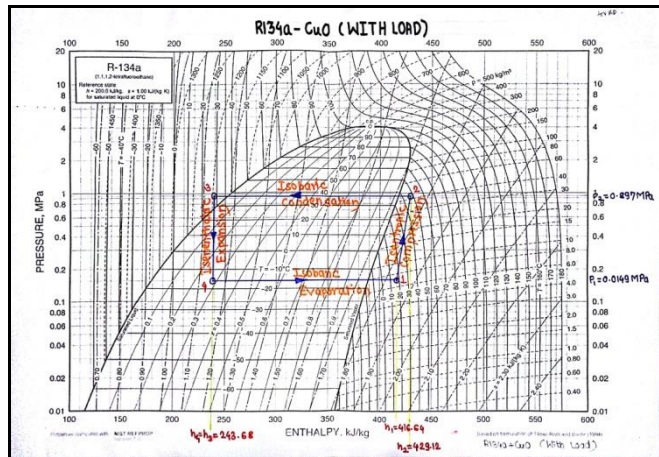

Fig4: Pressure Enthalpy(p-h) diagram for R134a

3.2.3. Trial on R134a with Al₂O₃ nanoparticles

2) Table-3: Observation table for R134a with Al₂O₃

P ₁ (bar)	P ₂ (bar)	T ₁ °C	T ₂ °C	T ₃ °C	T ₄ °C	R. E	C.W.	COP
1.9	11.5	30	60	38	20	181.2	11.2	12.96

From p-h chart

$$h_1 = 417.72 \text{ kJ/kg}$$

$$h_2 = 431.20 \text{ kJ/kg}$$

$$hf_3 = hf_4 = 245.64 \text{ kJ/kg}$$

$$\text{COP} = (h_1 - h_4) / (h_2 - h_1)$$

$$\text{COP} = (417.72 - 245.64) / (431.2 - 417.72)$$

$$\text{COP} = 12.96$$

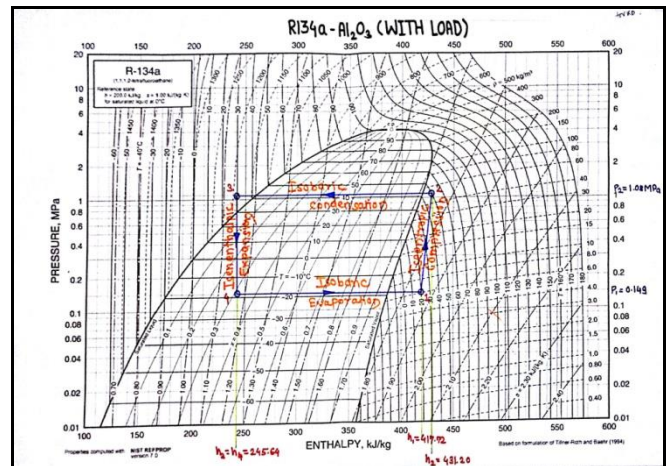

Fig.5: Pressure Enthalpy(p-h) diagram for R134a

3.2.4. Trial on MO49 with CuO nanoparticles

Table-4: Observation table for MO49 with CuO

P ₁ (bar)	P ₂ (bar)	T ₁ °C	T ₂ °C	T ₃ °C	T ₄ °C	R. E	C.W.	COP
1.3	10.4	31	55	33	5.4	177.9	12.5	14.19

From p-h chart

$$h_1 = 429.12 \text{ kJ/kg}$$

$$h_2 = 441.52 \text{ kJ/kg}$$

$$hf_3 = hf_4 = 252 \text{ kJ/kg}$$

$$\text{COP} = (h_1 - h_4) / (h_2 - h_1)$$

$$\text{COP} = (428.12 - 252) / (441.52 - 428.12)$$

$$\text{COP} = 14.19$$

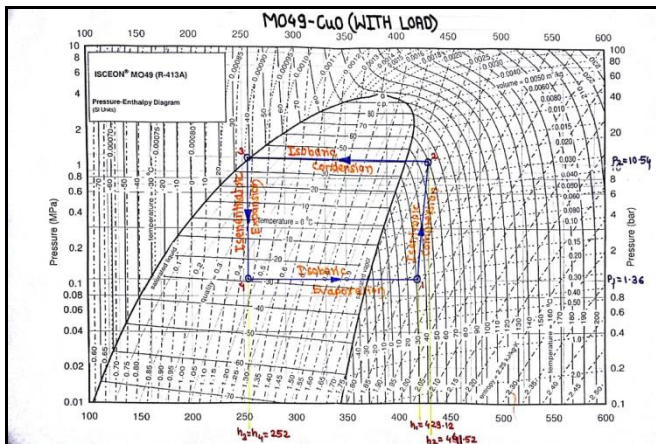

Fig.6: Pressure Enthalpy(p-h) diagram for R12

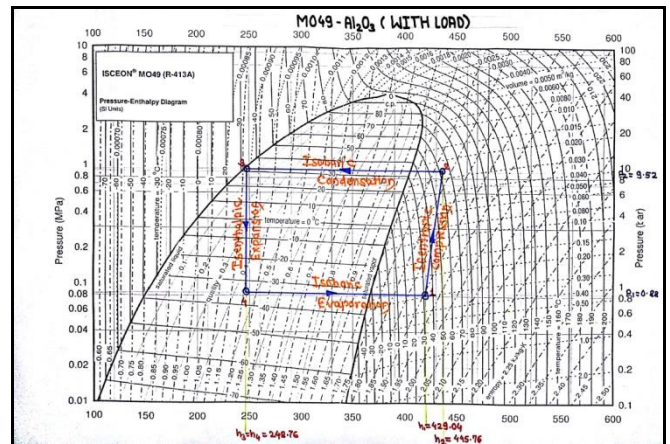

Fig.7: Pressure Enthalpy(p-h) diagram for R12

3.2.5. Trial on MO49 with Al₂O₃ nanoparticles

Table-5: Observation table for MO49 with Al₂O₃

P ₁ (bar)	P ₂ (bar)	T ₁ °C	T ₂ °C	T ₃ °C	T ₄ °C	R. E	C.W	COP
1.2	9.5 2	2 9	5 8	3 1	4.8	180.2	16. 7	10.78

From ph chart

$h_1 = 429.04 \text{ kJ/kg}$

$h_2 = 445.76 \text{ kJ/kg}$

$hf_3 = h_4 = 248.76 \text{ kJ/kg}$

$COP = (h_1 - h_4) / (h_2 - h_1)$

$COP = (429.04 - 248.76) / (445.76 - 429.04)$

$COP = 10.78$

3.2.6. Trial on R290 & R600a with CuO nanoparticles

Table-6: Observation table for R290 & R600a with CuO

P ₁ (bar)	P ₂ (bar)	T ₁ °C	T ₂ °C	T ₃ °C	T ₄ °C	R. E	C.W.	COP
1.0 8	8.4 3	3 5	5 8	3 6	5	376.7	28.06	13.4

From ph chart

$h_1 = 633.82 \text{ kJ/kg}$

$h_2 = 661.88 \text{ kJ/kg}$

$hf_3 = h_4 = 257.12 \text{ kJ/kg}$

$COP = (h_1 - h_4) / (h_2 - h_1)$

$COP = (633.82 - 257.12) / (661.88 - 633.82)$

$COP = 13.42$

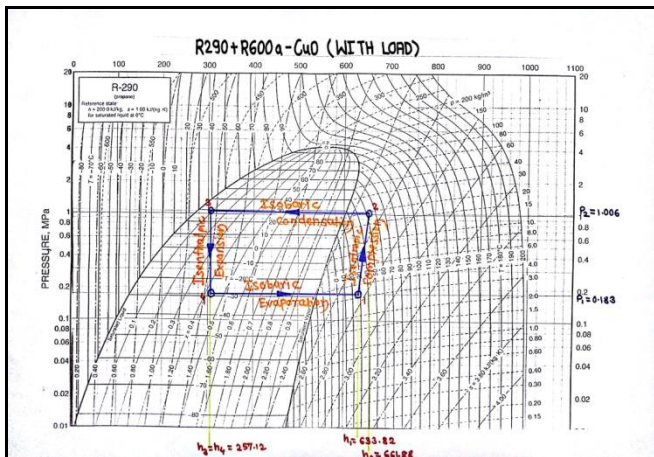

Fig.8: Pressure Enthalpy(p-h) diagram for R290+R600a

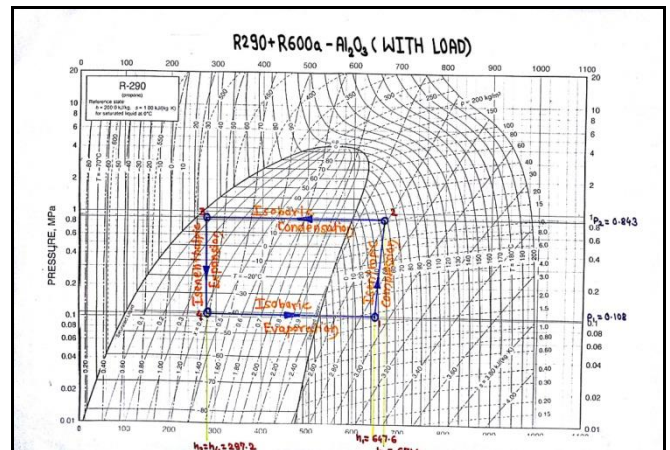

Fig.9: Pressure Enthalpy(p-h) diagram for R290+R600a

3.2.7. Trial on R290 & R600a with CuO nanoparticles

Table-7: Observation table for R290 & R600a with Al₂O₃

P ₁ (bar)	P ₂ (bar)	T ₁ °C	T ₂ °C	T ₃ °C	T ₄ °C	R. E	C.W	COP
1.8	10.6	26	52	38	4.4	350.4	23.8	14.72

From p-h chart

$$h_1 = 647.6 \text{ kJ/kg}$$

$$h_2 = 671.4 \text{ kJ/kg}$$

$$h_{f3} = h_4 = 297.2 \text{ kJ/kg}$$

$$COP = (h_1 - h_4) / (h_2 - h_1)$$

$$COP = (647.6 - 297.2) / (671.4 - 647.6)$$

$$COP = 14.72$$

4. RESULTS

4.1. Comparison between R134a without nanoparticles and with nanoparticles

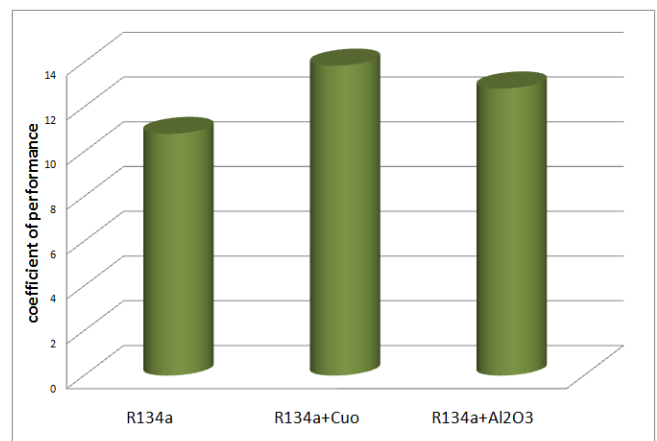

Chart 1. R134a without nanoparticles and with nanoparticles

4.2. Comparison between 3 refrigerants with CuO nanoparticles on the basis of time

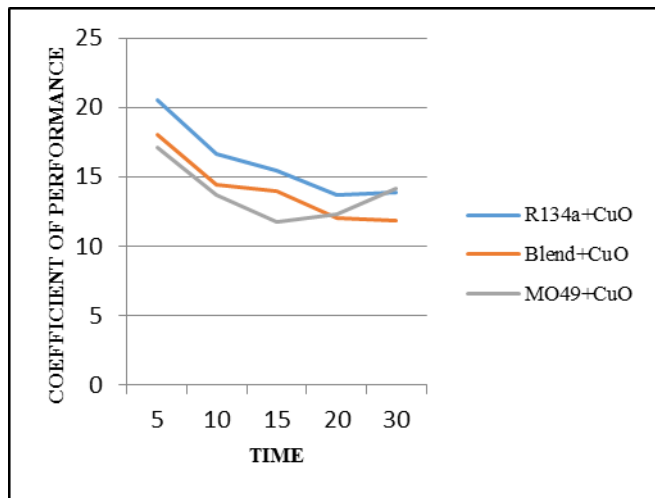

Chart 2: Three refrigerants with CuO nanoparticles

4.3. Comparison between 3 refrigerants with Al₂O₃ nanoparticles on the basis of time

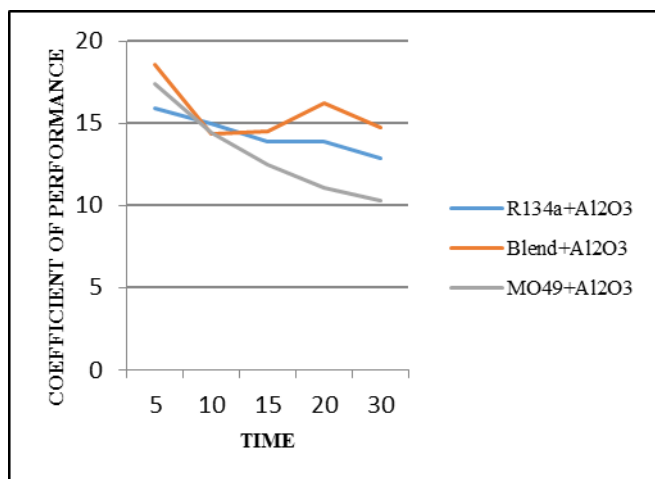

Chart 2. Three refrigerants with Al₂O₃ nanoparticles

4.4. COP of nanorefrigerants after 30 minutes at load condition

Table-7: COP of nanorefrigerants

	R134a	R290+R600a	MO49
CuO	13.85	11.83	14.19
Al ₂ O ₃	12.83	14.72	10.78

4.5. Comparison between CuO and Al₂O₃ with 3 refrigerants on the basis of time

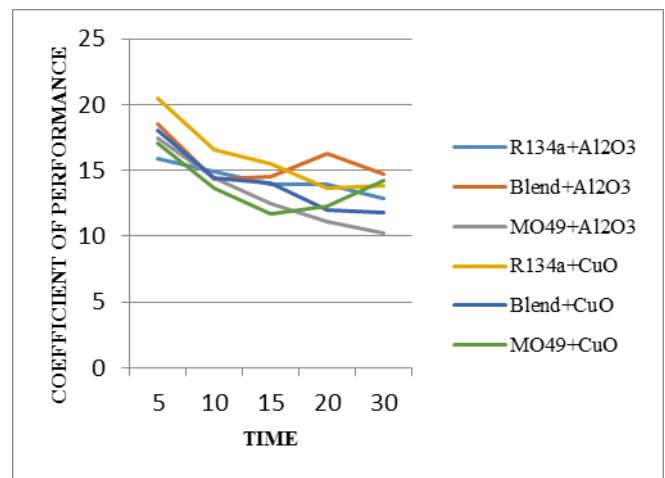

Chart 3. Comparison between CuO and Al₂O₃ with refrigerants

5. CONCLUSIONS

1. The COP of refrigeration system with nanoparticles is more than COP of refrigeration system without nanoparticles.
2. The COP of refrigeration system with nanoparticles is increased by 4-5%.
3. COP of CuO nanoparticles is more than Cop of Al₂O₃ nanoparticles with refrigerants.
4. COP also differs with types of refrigerants R134a, R290 & R600a and MO49.
5. The heat transfer rate and thermal conductivity of system will increased by using nanorefrigerants.

ACKNOWLEDGEMENT

We would like to express our sincere gratitude towards our guide, Prof.V.K.Dongare for the help, guidance and encouragement. This work would have not been possible without his valuable time, patience and motivation. We thank him for making our stint thoroughly pleasant and enriching. We are deeply indebted to H.O.D. of Mechanical Dept. Prof.S.R.Bhandari and Prof.A.R.Suware. They supported us with scientific guidance, advice and encouragement, it was always helpful and enthusiastic and this inspired us in our work.

REFERENCES

- [1].**Senthilkumar and R. Praveen**, "Performance analysis of a domestic refrigerator using CuO-R600a nano - refrigerant as working fluid," Journal of Chemical and Pharmaceutical Sciences, JCHPS, Special Issue 9, (2015), pp. 30-33.
- [2].**D. Sendil Kumar, Dr. R. Elansezhian**, Experimental Study on Al2O3-R134a Nano Refrigerant in Refrigeration System, "International Journal of Modern Engineering Research", Vol. 2, Issue. 5, 2012, pp.3927-3929.
- [3].**Vaishali P. Mohod and Nishikant**, W. Kale, "A Review on heat transfer enhancement using nanoparticles suspended with refrigerants/lubricating oils in refrigeration systems," International Journal of Innovative and Emerging Research in Engineering Volume 2, Special Issue 1 MEPCON (2015), pp. 191-194.
- [4].**Rejikumar.R and Sridhar.K**, (Apr 2013) Heat transfer enhancement in domestic refrigerator using nanorefrigerant as working fluid, Int. J. Comp.Eng. Res., 3(4).
- [5].**D.Sendil Kumar, R.Elansezhian**, "Experimental study on Al2O3-R152a Nanorefrigerant in Refrigerant System",International Journal of Modern Engineering Research, Vol 2,Issue 5, 2012,pp3927-3929.
- [6]. **N. Subramani, M. J. Prakash**, Experimental studies on a vapour compression system using nanorefrigerants, "International Journal of Engineering, Science and Technology", Vol. 3, issue no. 9, 2011, pp. 95-102.
- [7].**I.M. Mahbul, R. Saidur and M.A. Amalina**, "Investigation of Viscosity of R-123-TiO2 Nanorefrigerant, "International Journal of Mechanical and Materials Engineering", Vol. 7, issue 2, 2012,pp. 146-151.

[8].**Mr. Nilesh S. Desai and Professor P.R. Kulkarni**, "A Review on performance of refrigeration system using nanofluids," International Journal for Scientific Research & Development, Vol. 3, Issue 02, (2015), pp. 2390-2394

[9].**Parvinder Singh**, "To study the application of nanorefrigerant in refrigeration system: a review," International Journal of Research in Engineering and Technology, Volume 04, Issue 06, (2015), pp. 414-417

[10].**R. Krishna Sabareesh**, Application of TiO2 nanoparticles as a lubricant-additive for vapour compression refrigeration systems -An experimental investigation.

BIOGRAPHIES



Prof. Vaibhav K. Dongare. *Work Profile: Assistant Professor Department of Mechanical Engineering, Rajendra Mane College of Engineering and Technology.*



Ms. Jyoti T. Kadam. *Student of Mechanical Engineering. Work Profile: working on Enhancement of VCERS using nanofluids.*



Ms. Amruta C. Samel. *Student of Mechanical Engineering. Work Profile: working on Enhancement of VCERS using nanofluids.*



Ms. Rupali S. Pawar. *Student of Mechanical Engineering. Work Profile: working on Enhancement of VCERS using nanofluids.*



Ms. Sampada C. Sarvankar. *Student of Mechanical Engineering. Work Profile: working on Enhancement of VCERS using nanofluids.*