

VEHICLE SECURITY AND TRACKING SYSTEM WITH CLASH DRIVING ALERT

Mayur Pawar, Shivani Wakhare, Amit Yewale, Harsha Gawari

1Mayur Pawar, Dept. of E&TC Engineering, Dhole Patil College Of Engg.Pune, Maharashtra, India.

2Shivani Wakhare, Dept. of E&TC Engineering, Dhole Patil College Of Engg.Pune, Maharashtra, India.

3Amit Yewale, Dept. of E&TC Engineering, Dhole Patil College Of Engg.Pune, Maharashtra, India

4 Professor Harsha Gawari, Dept. of E&TC Engineering, Dhole Patil College Of Engg.Pune, Maharashtra, India.

Abstract - In present growing economy, the country faces the uprising of the crime rate and vehicle theft occur, which is the main concern for conducting this project. The safety of vehicles is extremely essential for public vehicles. Vehicle tracking and locking system is installed in the vehicle, to track the place and locking engine motor. The place of the vehicle is identified using Global Positioning system (GPS) and Global system mobile communication (GSM). This systems constantly watches a moving Vehicle and reports the status on demand. When the theft is identified, GSM send SMS to the microcontroller, then the microcontroller issues the control signals to stop the engine motor. Authorized person needs to send the password to controller to restart the vehicle and open the door. This is a more secured, reliable and low cost system.

Key Words: GPS, GSM, Ultrasonic sensor ,Servo Motor, DC Motor, Keypad, Electronic Key ,LCD, Accelerometer.

1. INTRODUCTION

Vehicle security system has been a topic of great interest over the years due to the increasing vehicle theft cases reported all over the world. Most of the advanced vehicle security systems best suit the four wheelers. As far as the security system for two wheelers is concerned, the systems available in market are of no match to the well equipped thieves. When under attack, these systems can only immobilize the engine and sound a loud alarm. It is a serious limitation. In this paper we propose a reliable and robust design of Vehicle Security System (VSS) with features enhancing the security of the vehicle and ensuring the safety of the rider. In our proposed security system various new features are included in addition to the engine immobilizer and alarm. Few of the important features supported by this system are alerting owner by SMS about the theft attempt, allowing user to control the system remotely by SMS,

tracking the location of vehicle using GPS technology, Remote Keyless System, servo motor operated locking system. Redundancy is maintained to make the system reliable even in the worst case scenario, but due to cost constraints a tradeoff between cost and redundancy was necessary. This system is designed to be compatible with almost all the brands of vehicle.

In this system we are going to use two keys to open the vehicle lock one is the electronic key which is generally used in every vehicle now and another one is the password key for which we are going to use a 4*4 matrix keypad. Firstly the user should have the vehicle key and he should know the correct password for vehicle. If the user has keys but he enters an incorrect password then a warning SMS will be sent to the registered mobile number.

Currently GPS vehicle tracking ensures their safety as travelling. This vehicle tracking system is found in client's vehicles as a theft prevention and rescue device. Vehicle owner or Police follow the signal emitted by the tracking system to locate a robbed vehicle in parallel to the stolen vehicle engine speed going to decreased and pushed to off. After switching of turning off the engine, the motor cannot restart without permission of password. This system is installed for four wheelers, Vehicle tracking is usually used in navy operators for navy management functions, routing, send off, on board information and security. The applications include monitoring driving performance of a parent with a teen driver. Vehicle tracking systems is accepted in consumer vehicles as a theft prevention and retrieval device. If the theft is identified, the system sends the SMS to the vehicle owner. After that vehicle owner sends the SMS to the controller, issue the necessary signals to stop the motor.

2. LITERATURE SURVEY

Montaser N. Ramadan et al. introduces an efficient automotive security system. This system is implemented for anti-theft using an embedded system occupied with a Global Positioning System and a Global System of Mobile. The client interacts through this system with

vehicles and determines their current locations and status using Google Earth. The user can track the position of targeted vehicles on Google Earth. Using GPS locator, the target current location is determined and sent, along with various parameters received by vehicle's data port, via Short Message Service (SMS) through GSM networks to a GSM modem that is connected to a computer or a laptop. The GPS coordinates are corrected using a discrete Kalman filter. In this paper, a low-cost vehicle tracking and monitoring system is presented

accelerometer sensor to sense whether the vehicle is moving or steady and a compass sensor for identifying the direction of moving vehicle.

In this proposed work, a novel method of vehicle tracking and locking system is used to track the theft of the vehicle by using GPS and GSM technology. This system is used mode of operation changed by person or remotely. The controller issues the message about the place location of the vehicle to the car owner or authorized person.

3. BLOCK DIAGRAM

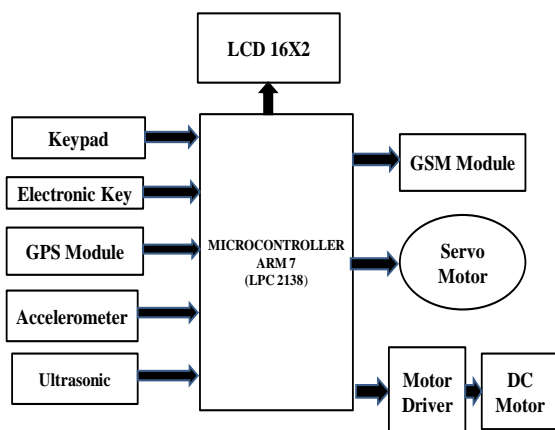

Fig.3: Block Diagram Of The System

3.1 Block Diagram Description

The above block diagram explains the working of the system which can be designed from this paper, A ARM processor LPC2148 is used here for automation and controlling other supporting devices like GPS, GSM, Accelerometer sensor compass sensor. Actually this gives the practical model of a vehicle tracking system which can do routing, tracking of moving vehicles in large area. It consists of two sections, first which will be inbuilt in the car which is having GPS in it and as the car moves, the location of the car goes on changing continuously, the GPS finds the location in terms of two coordinates that are Longitude and latitude. These coordinates are communicated to another section by GSM modem, as shown in the block diagram Fig.3 and both the parts consist GSM for communication. This GSM is connected to the computer through RS232 which has internet connection. So that as soon as the co-ordinates are received, it can be located in the Google Earth. As shown in block diagram Fig.3 two more sensors are used that are,

4. HARDWARE REQUIREMENT

4.1 Microcontroller LPC2138

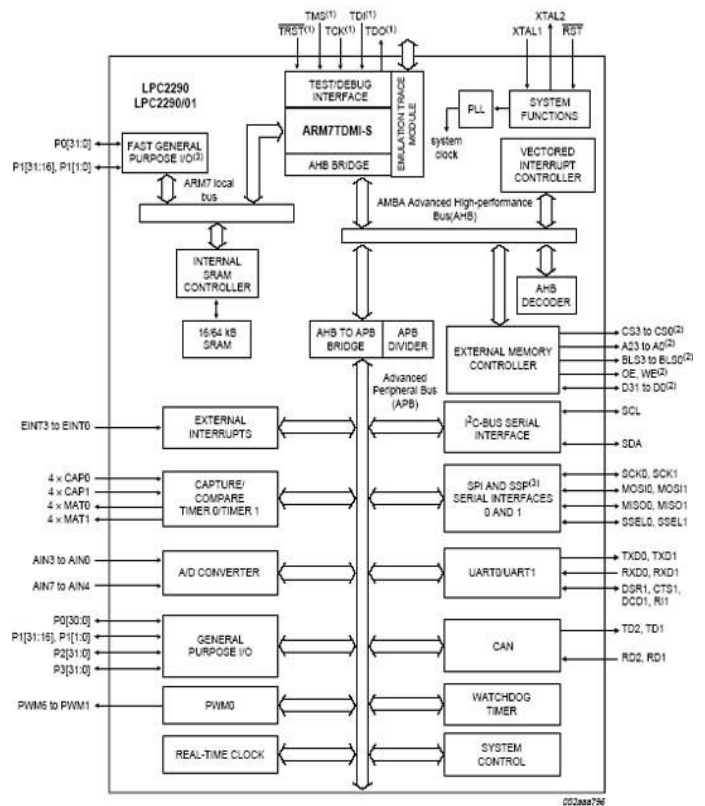

Fig.4.1: Block Diagram Of LPC2138

The LPC2138 microcontrollers are based on a 16-bit/32-bit ARM7TDMI-S CPU with real-time emulation and embedded trace support, that combine the microcontroller with embedded high-speed flash memory ranging from 32 kB to 512 kB. A 128-bit wide memory interface and unique accelerator architecture enable 32-bit code execution at the maximum clock rate.

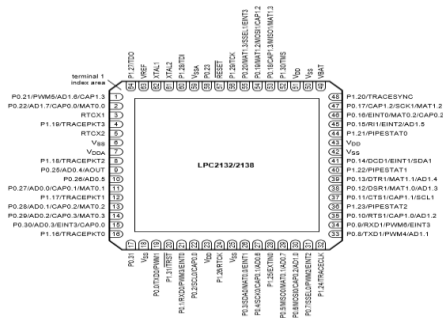

Fig.4.1.1: Pin Configuration of LPC2138

Features

- It is a 16-bit/32-bit ARM7TDMI-S microcontroller.
- It has a 8 kB to 40 kB of on-chip static RAM and 32 kB to 512 kB of on-chip flash memory.
- It has a single 10-bit DAC provides variable analog output.

4.2 GPS

SIM28

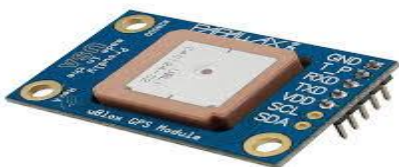

Fig.4.2: GPS Module

Features

- It has a RS232 interface via DB9 Connector
- Its operates at a 3.3 V power Supply
- It has a 24mA power consumption

4.3 Acclerometer

ADXL335 Triple Axis Accelerometer

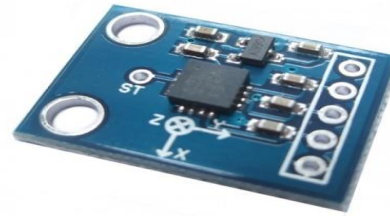

Fig.4.3: Accelerometer Module

Features

- It has a 3-axis sensing
- Smaller in size
- It operates at a low power : 350 µA
- good temperature stability

4.4 GSM Module

SIM900A GSM Module



Fig.4.4: GSM Module

SIM900 GSM Module this means the module supports communication in 900MHz band.

- It is a compatible with ARDUINO, RASPBERRY PI, ARM, AVR, PIC, 8051, etc.
- It can be directly connected to computer via Serial Port.
- It has a ption for connecting MIC and SPEAKER directly to GSM MODEM for calls .
- DEBUGGER Pins existing
- operating temperature: -20 °C to +55 °C
- Input Voltage is: 12V DC.

Features

- It controls via AT commands.
- It is a SIM application toolkit.
- Supply voltage range is: 3.1- 4.8V
- It has a low power consumption: 1.5mA

4.5 Servo Motor

VS-1 vigor



Fig.4.5: Servo Motor Module

Features

- Output angle is 120 degree.
- its Operates on 5V
- Operating Voltage is 4.8V to 6.0V (DC)
- Operating Current is 0.25A to 0.35A

4.6 LCD

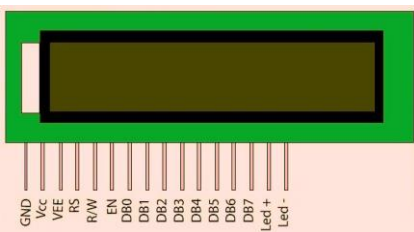

Fig.4.6: LCD

16x2 Character LCD is a very fundamental LCD module which is generally used in electronics projects and products. It contains 2 rows that can display 16 characters. Every character is displayed using 5x8 or 5x10 dot matrix. It can be simply interfaced with a microcontroller.

Features

- It has alphanumeric display.
- Use for a General Purpose
- It is a 16x2 character LCD.
- It has a Green LED Backlight.

4.7 Ultrasonic Sensor

Ultrasonic Ranging Module HC - SR04



Fig4.7: Ultrasonic Module HC-SR04

Ultrasonic ranging module HC - SR04 provides 2cm - 400cm non-contact measurement function, the ranging accurateness can reach to 3mm. The modules comprises ultrasonic transmitters, receiver and control circuit.

4.8 Buzzer



Fig.4.8: Buzzer

Features

- Sealed: yes
- It operates at a 3-6V DC / 25Ma power
- very small and ultrathin construction
- Less electrical noise
- It has a low current consumption

Buzzer is an acoustic signal in device, which may be mechanical, electromechanical , or piezoelectric.Uses of buzzer contains alarm devices, timer & validation of user input such as a mouse click or keystroke.

4.9 DC Motor



Fig.4.9: DC Motor

6. LAYOUT

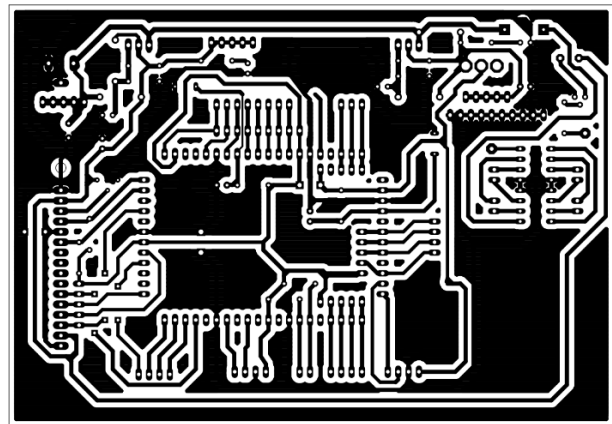

Fig.6: Layout Of System

Features

- Operate in both direction, by switching voltage polarity
- Spin very fast: >1000 RPM
- It needs gearing

4.10 KEYPAD

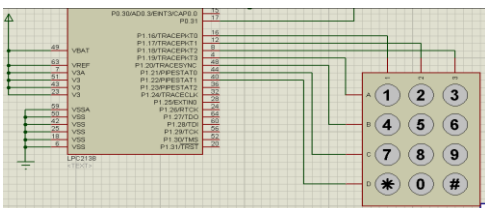
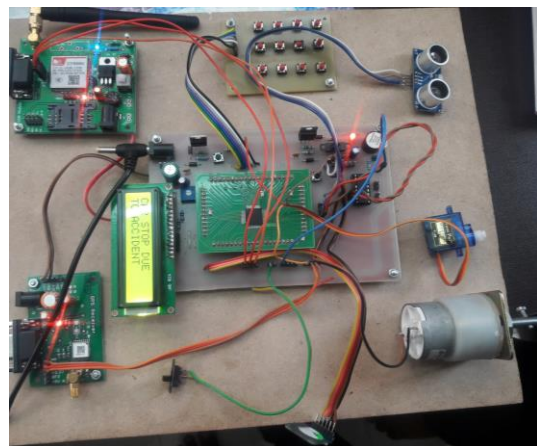

Fig.4.10: 4*3 Keypad

The rows R0 to R3 are connected to Input lines of Microcontroller. The i/o pins where they are connected are made Input. The column C0 to C3 are also connected to MCUs i/o line. These are kept at High Impedance State, in high z state (z= impedance) state these pins are neither HIGH or LOW they are in TRISTATE

7. RESULT



8 . ADVANTAGES

- As the whole system operates on the battery voltage, low power consuming.
- In an unfortunate event that your vehicle is stolen, having an auto alarm installed with a tracking device can result in the quick recovery of the vehicle.
- It provides more security.
- It is easy to find the theft.
- It gives the location of vehicle when accident alert.
- It avoids accidents.
- A car alarm is a simple device that sends a message to the potential thief that there is a high likelihood

5. CIRCUIT DIAGRAM

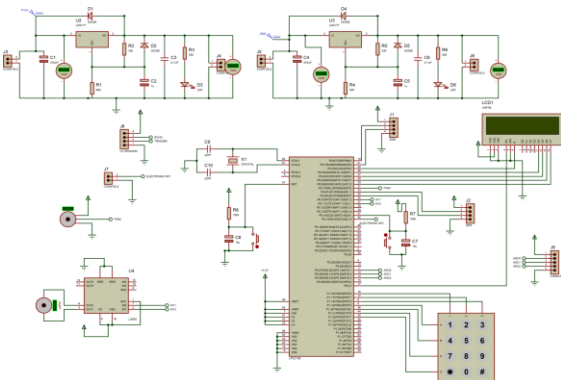

Fig.5: Circuit Diagram

that someone will be alerted if they attempt to perpetrate the crime

9. APPLICATIONS

- As the system provides more security it can be used in military.
- This System can be used in Ambulance for accident alerts.

10. CONCLUSION

The design and implementation of this system allows safety and security system to the car. A simple, cost effective anti-theft security system has been successfully designed and constructed. This system also detects an accident and sends information to service provider. The technologies of speed, the GSM / GPRS wireless transmission have good perspective in the auto safety domain's application. The advantage of the system is that the status of vehicle owner could be identified effectively which prevents the criminal from stealing. In addition to this, this system will reduce the accidents and save the human lives. On the whole, this system is very cost effective and efficient. This system can be easily implemented in real time.

ACKNOWLEDGEMENT

The authors are sincerely thankful to the unanimous reviewers for their critical comments and suggestions to develop the quality of the manuscript.

REFERENCES

[1] Pritpal Singh, Tanjot Sethi, Bibhuti Bhusan Biswal, and Sujit Kumar Pattanayak, "A Smart Anti-theft System for Vehicle Security," Security, especially theft security of vehicle in common parking places has become a matter of concern. An efficient automotive security system is implemented for anti-theft using an embedded system integrated with Global

Positioning System (GPS) and Global System for Mobile Communication (GSM).

International Journal of Materials, Mechanics and Manufacturing, Vol. 3, No. 4, November 2015.

[2] Sathé Pooja, "Vehicle Tracking System Using GPS", In the present growing economy, the country also faces the uprising of crime rate. Car theft, which is the main concern for the conduct of this project.

International Journal of Science and Research (IJSR), India Online ISSN: 2319- 7064, Volume 2 Issue 9, September 2013, www.ijsr.net.

[3] R.Ramani, S.Valarmathy, "Vehicle Tracking and Locking System Based on GSM and GPS", The safe of vehicles is extremely essential for public vehicles. Vehicle tracking and locking system installed in the vehicle, to track the place and locking engine motor.

I.J. Intelligent Systems and Applications, 2013, 09, 86-93.