

## VOICE CONTROLLED ROBOTIC ARM

Abhinav Salim<sup>1</sup>, Ananthraj C R<sup>2</sup>, Prajin Salprakash<sup>3</sup>, Babu Thomas<sup>4</sup>

<sup>1</sup>Student, Electrical and Electronics Engineering, Mar Athanasius College of Engineering, Kothamangalam

<sup>2</sup>Student, Electrical and Electronics Engineering, Mar Athanasius College of Engineering, Kothamangalam

<sup>3</sup>Student, Electrical and Electronics Engineering, Mar Athanasius College of Engineering, Kothamangalam

<sup>4</sup> Professor, Dept. of Electrical and Electronics Engineering, Mar Athanasius College of Engineering, Kerala, India

\*\*\*

**Abstract** - This project presents a system whereby the human voice may specify continuous control signals to operate a real 3D robotic arm. Our goal is to help the people with disabilities by assisting them in their daily activities with the help of a robotic arm. It is indeed possible for a user to learn to move the position of real-world objects with a robotic arm using only non-verbal voice as a control mechanism. Individuals with motor impairments such as those with paraplegia, spinal cord injuries, war-time injuries, or amputations rely on others to assist them in their daily activities. Advances in assistive technologies have begun to provide an increase in independence for these individuals, but there is great potential for further technological developments to significantly improve their abilities, independence, and overall quality of life.

**Keywords:** Speech Recognition, Arduino microcontroller, Robotic arm, Motor driver, Impairments

### 1. INTRODUCTION

The first term to be considered in voice control is Speech Recognition i.e. making the system to understand human voice. Speech recognition is a technology where the system understands the words (not its meaning) given through speech. At its most basic level, speech recognition allows the user to perform parallel tasks, while continuing to work with the computer or appliance. Use of robotic arm by people with disabilities provides a lot of independence in their daily life. The voice control provides a convenient and effortless way to control the robotic arm which can aid people who cannot move their hands. The robotic arm which we used for this project is a lightweight model which is controlled by four motors. The motors used are geared motors which are basically dc motors. They change the direction of rotation if the polarity is changed. Hence rotation in two directions is achieved. The automatic speech recognition system helps to understand spoken words which are recognized by a mike. The speech recognizer depends basically on HM2007 processor which is the heart of the speech recognizer. The analog voice input is transformed to digital commands. These commands are used as input to the arduino. An

advantage to this stand-alone speech-recognition kit is its programmability. The user can program and train this kit to recognize the unique words which is to be recognized. The Speech Recognition kit can be easily interfaced to the robotic arm's CPU. The CPU is an Arduino Mega Microcontroller board. Microcontroller also provides a PWM signal for controlling the speed and direction of rotation of the motor. The PWM output of the controller is fed to two motor drivers that drive the motors of the robotic arm.

### 1.1 Block Diagram

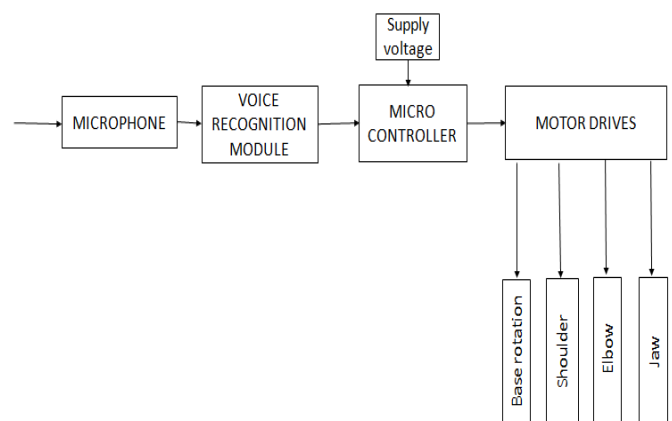

**Fig -1:** Block Diagram

The block diagram in figure 1 shows all the major components that is required for a voice controlled robotic arm using a microcontroller. The voice inputs are given through a microphone to the voice recognition module. The digital output corresponding to the voice command is provided to the microcontroller ( it requires an external power supply of 5V ). Microcontroller will generate the control signals to operate the four motors of the robotic arm. These signals are given to the motor drivers (to meet the additional power requirements of the motors). Motor drivers control the direction of rotation of the four motors.

### 1.2 Major Components

The major components used are Speech Recognition kit SR-07, Arduino Mega 2560 microcontroller, motor driver L293D and the robotic arm.

The Arduino Mega is a microcontroller board based on ATmega 2560. It has 54 digital input or output pins (of which 14 can be used as PWM outputs), 16 analog inputs, 4 UARTs (hardware serial ports), a 16 MHz crystal oscillator, a USB connection, a power jack, an ICSP header and a reset button. It contains everything needed to support the microcontroller.

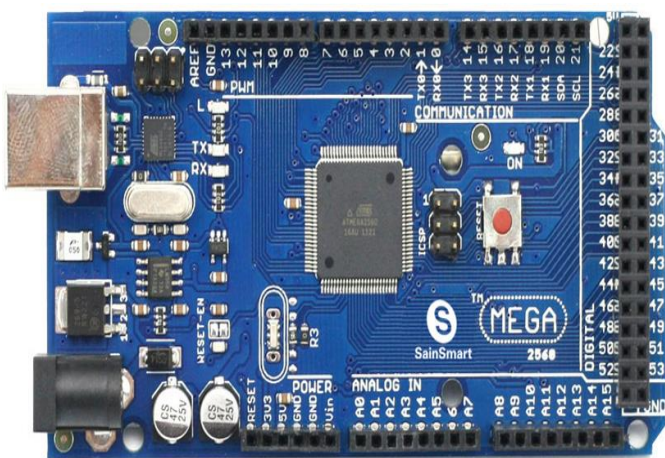

Fig -2: Arduino Mega microcontroller

The L293D is a quadruple high-current half-H driver. It is designed to provide bidirectional drive currents of up to 600-mA at voltages from 4.5 V to 36 V.

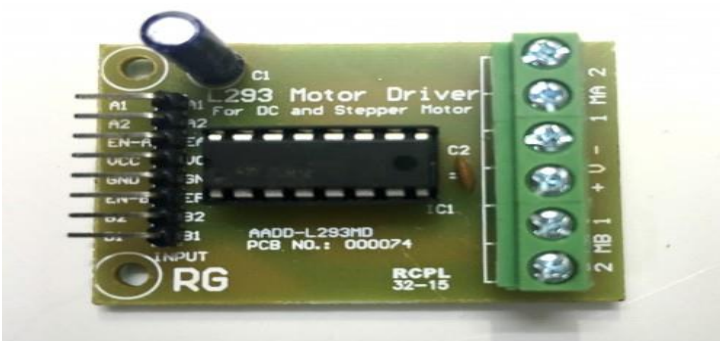

Fig -3: Motor Driver L293D

The speech recognition kit is a complete easy to build programmable speech recognition circuit; programmable, in the sense that the words to be recognized are trained into the module. This kit allows the user to experiment with many facets of speech recognition technology.



Fig -4: Speech Recognition SR-07

### 2. PROGRAM CONCEPT

Initially the output from the voice recognition module is of the state 00. The BCD of this state is given to the Arduino board. When a command is given to the voice module the corresponding number in which that particular word is stored is displayed on the 7-segment display. The BCD corresponding to it is given to the microcontroller. The nine conditions are then checked. If a particular condition is satisfied, appropriate signals are taken from the Arduino to the motor driver which drives the required motor.

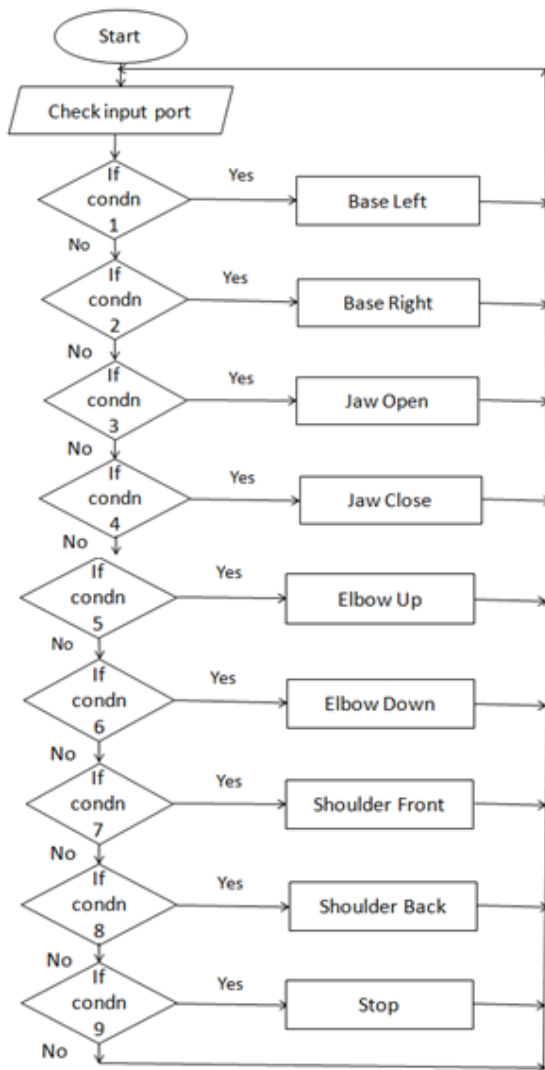

Fig -5: Program logic of voice control

### 2.1 Working

This project presents the working of a robotic arm using voice control. The main aim of this project is that it can be very useful for paralyzed people or people with motor impairments. The appropriate words to be recognized are first trained by the user using the speech recognition module. The words are stored in numbers ranging from 1 to 9 which is displayed on the 7-segment display. During working, when the user says a particular trained word into the microphone of the speech recognition module, the words are recognized by it and the corresponding BCD of the number in which the word is stored is taken out as the output. The output of the speech recognition kit is sent to the Arduino microcontroller. According to the inputs received by the Arduino, appropriate signals are now sent to the motor driver to rotate the required motor in the specific direction. Pulse width modulation is used to set the required speed with which the motor has to rotate. Thus, each part of the robotic arm can be controlled by controlling the direction of

that particular motor. The motor continues to rotate until the user says a second command or a stop command. When the stop command is said all the motors remain ideal.

### 3. HARDWARE IMPLEMENTATION AND RESULTS

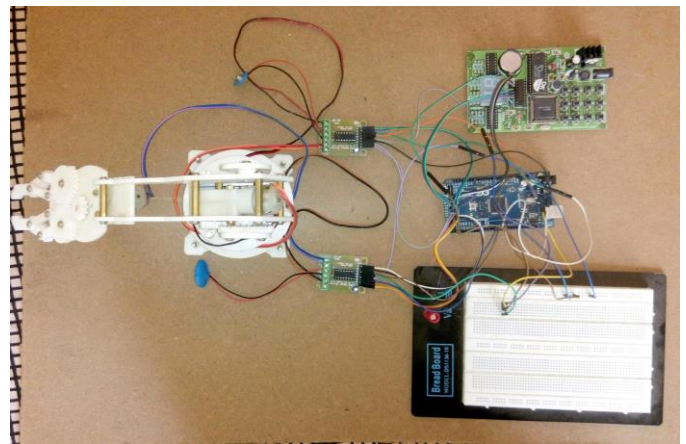

Fig -6: Completed hardware

The hardware and software of the voice controlled robotic arm were setup and tested for all voice command and tasks under different operating conditions. The robotic arm was used to pick up a lightweight object and was place it in its desired position. All the movements of the robotic arm was checked using the following voice commands:

- 1) Base left
- 2) Base right
- 3) Shoulder front
- 4) Shoulder Back
- 5) Elbow up
- 6) Elbow Down
- 7) Jaw Open
- 8) Jaw Close
- 9) Stop

### 4. CONCLUSIONS

Human-Robot interaction is an important, attractive and challenging area in robotics. The robot popularity gives the researcher more interest to work with user interface for robots to make it more user friendly to the social context. Speech recognition (SR) technology gives the opportunity to add natural languages communication with robot in natural and easy way. The working domain of the voice controlled robotic arm is to help the people in everyday life and to help those with disabilities. This project provides effortless control for robotic arm. The speech recognition module was interfaced to the robotic arm with the help of the arduino board. The input and output ports were selected conveniently and the arduino board was programmed accordingly. External power supplies were connected. The voice recognition module was trained to recognize the input commands and the completed project was realized in real time. The future work will focus on introducing more

complex activities and sentence to the system. Humans normally use gestures such as pointing a particular object for a particular direction along with spoken languages. When the human speaks with another human about a close object or location, they normally point at that object or location by using the fingers. This interface called multimode communication interface, which can be incorporated in the near future.

#### **ACKNOWLEDGEMENT**

We take this opportunity to extend my sincere thanks to my Project Guide Sri. Babu Thomas, Professor and all the members of the Department of Electrical & Electronics Engineering for sharing their valuable comments during the preparation of the project.

#### **REFERENCES**

- [1] A study on real-time control of mobile robot with based on voice command, Byoung-Kyun Shim ; Yoo-Ki Cho ; Jong-Baem Won;Sung-HyunHan Control, Automation and Systems (ICCAS), 2011 11th International Conference on Publication Year: 2011M. Young, The Technical Writer's Handbook. Mill Valley, CA: University Science, 1989.
- [2] Praveen Blessington<sup>1</sup>, B.T.P.Madhav<sup>1</sup> M. Sagar Babu<sup>2</sup>, R .Rajiv Reddy<sup>2</sup>, D. I. P. Mani Kumar<sup>2</sup>, I. Naga Raju<sup>2</sup>, N. Anil Babu<sup>2</sup>, Acoustic Controlled Robotic Vehicle - International Journal of Emerging Technology and Advanced Engineering (April, 2012) magazine.K. Elissa, "Title of paper if known," unpublished.
- [3] K. Kannan<sup>1</sup>, Dr. J. Selvakumar<sup>2</sup>, ARDUINO BASED VOICE CONTROLLED ROBOT, International Research Journal of Engineering and Technology (IRJET), Volume: 02, Issue: 01, March-2015
- [4] BrandiHouse, JonathanMalkin, JeffBilmes, The VoiceBot: A Voice Controlled Robot Arm Department of Electrical Engineering, University of Washington bhouse,jsm,bilmes@ee.washington.edu