

AUTOMATIC ELECTRONIC BUG SWATTER FOR ROOFTOP GARDENS BASED ON SOLAR ENERGY

V.Surendar¹, P.Pachiyammal², Rica Sarkar³, B.Saravanan⁴

Assistant professor, Dept. of EEE, Kongu Engineering College, Erode, Tamilnadu, India¹

UG Student, Dept. of EEE, Kongu Engineering College, Erode, Tamilnadu, India²

UG Student, Dept. of EEE, Kongu Engineering College, Erode, Tamilnadu, India³

UG Student, Dept. of EEE, Kongu Engineering College, Erode, Tamilnadu, India⁴

Abstract - In the current scenario, with the rising population more and more apartments are coming up resulting in rooftop gardens. The objective of our paper is to safeguard the rooftop plants from pests and to reduce the use of pesticides. Home gardens need to provide fresh fruits and vegetables for the better health of the family. In this project we use LED lights during night time to attract the insects and swatter electrocutes them instantly thus preventing them from reaching the plants. We also have a provision to collect the dead insects and dispose them back to the soil to be used as natural manure. During the day time, the ultrasonic sound generator is used to repel the insects. The solar energy which is a renewable source is used to recharge the batteries. The moisture level of the soil is also sensed automatically and accordingly water is fed to the plants. Our project is compact and movable. With all four applications combined in a single project, this will be very useful for the city dwellers. It will save their time and energy needed to look after the rooftop plants.

havens. Also pest management is one of the major expenditures incurred by a farmer. From sowing till the crops are harvested and sold, pests need to be managed effectively and economically. This paper aims to design and develop an automatic swatter to protect the rooftop plants from damage due to insects and pests, make judicious use of the pests by turning it into bio pesticides and an automatic watering system for the rooftop plants.

Key Words: Rooftop gardens, agriculture, Solar based electronic swatter, Ultraviolet LED lights, Ultrasonic sound Generator, ATmega 8A Microcontroller, Soil Moisture Sensor, pest control

1.1 System Architecture

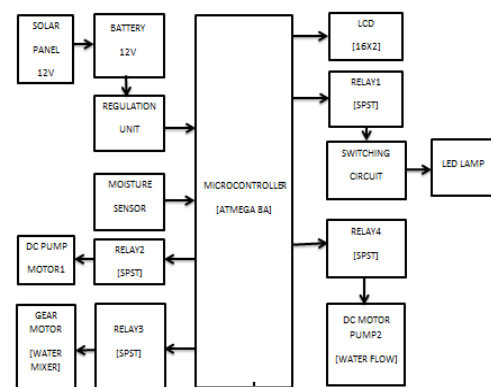

Fig 1 Block Diagram

1. INTRODUCTION

Urban populations face many challenges related to the health and well-being of citizens. Many of these challenges arise as the direct result of condensed urban surroundings. Intense competition for land decreases green space, and there is a subsequent spiritual detachment from agricultural roots and the natural world. Rooftop gardens are an excellent example of incorporating passive, eco-friendly technology into the new environment. Rooftop gardens help lessen the negative impacts of cities on the environment by: conserving water and energy, improving air and water quality, helping in storm water management, absorbing solar radiation, becoming a source of local food production, providing habitat restoration, and creating natural

From the above figure the power supply from 12V battery is regulated to 5V DC using regulator and given to microcontroller, as it works at 5V. A relay connected to the microcontroller switches ON the LED Strips during night time and the ultrasonic sound generator during morning time. A DC Boost Converter boosts the input 6V to 1000V. The boosted voltage is fed to the swatter. The bug is then mixed with water using a mixer. Gear motor operates the mixer which rotates at 30 rpm. Submersible Pump Motor is used to pump out the mixture through the outlet pipe.

1.2 Hardware Used

- a) Power supply
- b) Microcontroller-Atmega8A
- c) Humidity Sensor-LM393
- d) LCD Display
- e) Relay
- f) Dc Gear Motor
- g) Dc Pump Motor
- h) Led Strips
- i) Ultrasonic Sound Generator

POWER SUPPLY

A power supply unit is required to deliver power to the load. The main function of the power supply unit is to provide required power for the operating devices without any interruption. The supply is taken from a battery (a pair of 6V) which gives an output of 12V and is regulated to 5V and this supply is given to the microcontroller and the receiving section. IC 7805, a voltage regulator used to regulate 12V into constant 5V. The filter circuit is used to eliminate the harmonics. Then the output voltage is given to the receiving swatter.

ATMEGA8A



Fig 2

The high-performance, low-power Microchip 8-bit AVR RISC-based microcontroller combines 8KB ISP flash memory with read-while-write capabilities, 512B EEPROM, 1KB SRAM, 23 general purpose I/O lines, 32 general purpose working registers, three flexible timer/counters with compare modes, internal and external interrupts, serial programmable USART, a byte oriented two-wire serial interface, 6-channel 10-bit A/D converter (8-channel in TQFP and QFN/MLF packages), programmable watchdog timer with internal oscillator, SPI serial port, and five software selectable power saving modes. The device operates between 2.7-5.5 volts. By executing powerful instructions in a single clock cycle, the device achieves throughputs approaching 1 MIPS per MHz, balancing power consumption and processing speed.

HUMIDITY SENSOR



Fig 3

Humidity sensors measure the volumetric water content in the environment. Technologies commonly used include:

- The moderator properties of water for neutrons are utilized to estimate soil moisture content between a source and detector probe.
- Electrical resistance of the soil

From calculations based on physical principles, or especially by calibration with a reference standard, these measured quantities can lead to a measurement of humidity. Modern electronic devices use temperature of condensation. Here in this project changes in electrical capacitance or resistance is used to measure humidity changes.

LCD MODULE

A liquid-crystal display is a flat-panel display or an electronically modulated optical device that utilises the light-modulating properties of liquid crystals. Liquid crystals do not emit light directly, instead using a backlight or reflector to produce images in color or monochrome. 16X2 LCD is used for display purposes.

RELAY

A relay is an electrically operated switch. Relays are used where it is required to control a circuit by a low-power signal or where several circuits must be controlled by one signal. A relay will switch one or more poles, each of whose contacts can be thrown by energizing the coil.

DC MOTOR

Gear motor of 12 v is used for mixing purposes. Key features of gear motors are easy to use and mount, standard size for all RPM's, a huge variety of RPM's available, long durability and very affordable. Gear motor starts control and process functions in combination with inverter technology and has thus evolved into the intelligent geared motor. Submersible pump motor pumps out the dead insects back to the soil as natural manure. Another pump motor feeds water when the moisture content is low.

LED STRIPS

For several decades pest management used exterior white incandescent or florescent bulbs to less attractive yellow bulbs, and mercury vapor lights to less attractive sodium vapor lights. Recently, the lighting industry has brought LED lights into the market for outdoor use. Humans can see light wavelengths in the electromagnetic spectrum ranging from 400-800 nm which includes violet to red colour, but does not include ultraviolet (UV) light at 350 nm. Insects can observe light in the 300-650 nm range, but prefer light that is between 300-420 nm which includes UV light. UV output of a light is probably the most essential factor in its attractiveness to insects. Since most insects are fascinated to UV light, most Insect Light Traps utilize UV bulbs as their source of attraction.

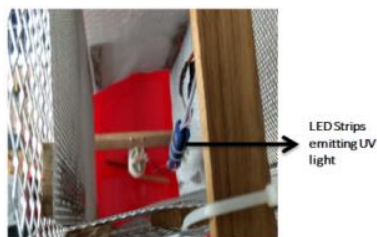

Fig 4

ULTRASONIC SOUND GENERATOR

It is possible that pests like insects, ants, rats, mice etc. are repelled by ultrasonic frequency in the range of 30 kHz to 50 kHz. Human beings can't hear these high-frequency sounds. Our project repels pests by emitting pulsed ultrasonic waves. Using ultrasonic waves creates a noisy and hostile environment which repels pests, whilst remaining absolutely safe for humans and household animals. Unfortunately, all pests do not react at the same ultrasonic frequency. While some pests get repelled at 35 kHz, some others get repelled at 38 to 40 kHz or even higher frequencies. Thus to make it more effective, frequency of ultrasonic oscillator has to be continuously varied between certain limits. Frequency of emission of ultrasonic sound is continuously varied in different patterns to repel different insects.

1.3 Software Description

The platform used is AVR Studio. AVRs have a large affordability due to the free and inexpensive development tools available, including reasonably priced development boards and free development software.

Current AVRs offer a wide range of features:

- Multifunction, bi-directional general-purpose I/O ports with configurable, built-in pull-up resistors
- Multiple internal oscillators, including RC oscillator without external parts
- Internal, self-programmable instruction flash memory up to 256 kB (384 kB on XMEGA)
- In-system programmable using serial/parallel low-voltage proprietary interfaces or JTAG
- Optional boot code section with independent lock bits for protection
- On-chip debugging (OCD) support through JTAG or debugWIRE on most devices
- The JTAG signals (TMS, TDI, TDO, and TCK) are multiplexed on GPIOs. These pins can be configured to function as JTAG or GPIO depending on the setting of a fuse bit, which can be programmed via ISP or HVSP. AVRs with JTAG come with the JTAG interface which is enabled by default.
- debugWIRE uses the /RESET pin as a bi-directional communication channel to access on-chip debug circuitry. It is available on devices with lower pin counts, as it requires only one pin.
- Internal data EEPROM up to 4 kB
- Internal SRAM up to 16 kB (32 kB on XMEGA)

1.4 Circuit Diagram

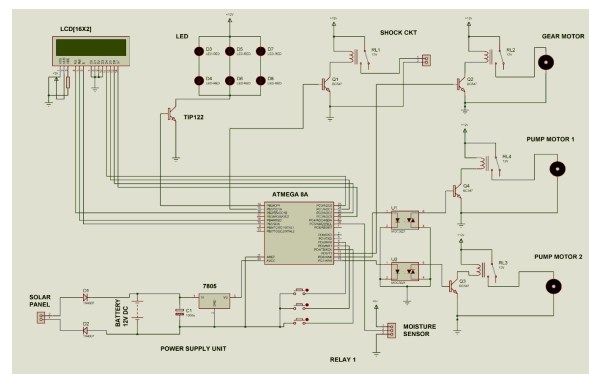

Fig 5

There are two 6V batteries which are connected in series to supply 12V in the proposed work. 12V is converted into 5V using LM 7805 Voltage Regulator with capacitor filter and is connected to Vcc of microcontroller as microcontroller works only on 5V. 12V supply is directly given to energize the driver ICs as 12V DC motor needs to be rotated using this driver. The outputs of the four relays are connected to four input pins of microcontroller through transistor amplifier circuitry. Depending on the inputs of these relays, control signal is given to driver IC by microcontroller. The predefined values which are used as signals are embedded as coding in microcontroller.

1.5 EXECUTION OF OUTPUT

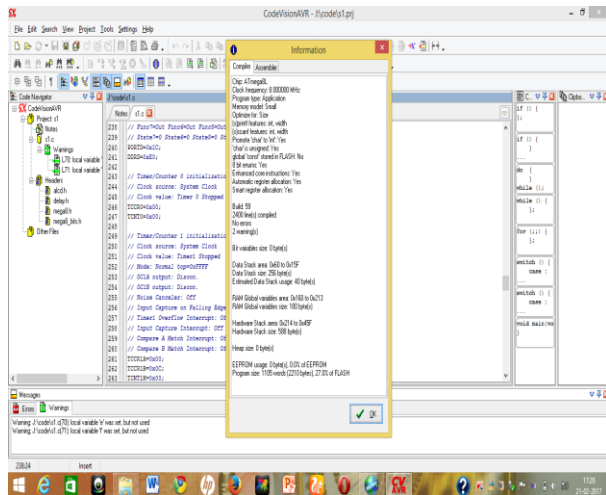

Fig 6

The four relays are interfaced with microcontroller. This project works completely based on the delay time given in the coding of microcontroller and predefined signals given to the driver IC for correct rotation of DC gear motors. By using trial and error method, the delay is given in the coding of microcontroller to rotate the motors. The code is executed using Code Vision AVR with no errors and this program is successfully written into the microcontroller. LED strips successfully attract the pests and the ultrasonic sound generator produces 20-30 kHz which successfully repels the little bugs. The moisture sensor senses the humidity of the soil successfully which is displayed on the LCD. The mixture is successfully pumped out of the storage tub and fed to the plants.

2. HARWARE SETUP

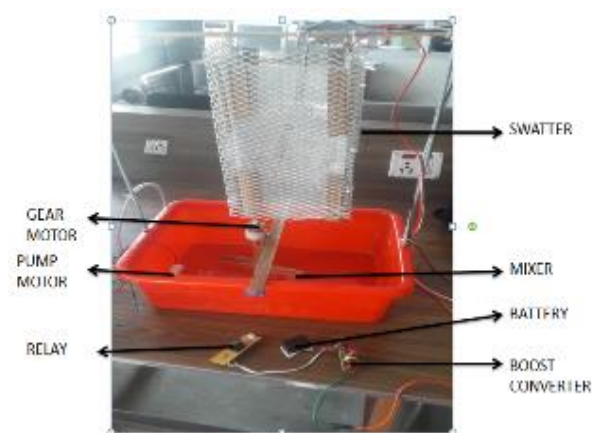

Fig 7 Swatter with the storage tub



Fig 8 Hardware Circuit



Fig 9

This setup deals with attracting insects using Led strips, repelling insects using ultrasonic sound generator, turning insects into bio pesticides and based on the moisture content feeding water in the soil all in a single project. Instead of using a separate machine for various purposes, we are using a single machine. Here manual efforts will be reduced. Humidity is sensed by the moisture sensor. This ensures proper water management. We are using gear motor for mixing and pump motors to pump out the water when required. Insects are collected automatically.

3. CONCLUSION

The great advantage of this project is that we must no longer worry about the problems in the residential buildings which house rooftop plants. No need of human effort to look after the rooftop plants. By placing the electronic bug swatter inside the residential buildings and just turning it ON will safeguard the plants automatically without human intervention. This project reduces the use of harmful pesticides and thereby promotes green gardening. Growing our own food gives us complete control over the chemicals and products used during the growing process. The produce retains more nutrients when consumed shortly after harvesting, making homegrown vegetables a healthier option. Over-watering can lead to soluble nutrients leaching beyond the root zone thereby predisposing the soil to fungi disease, oil compaction, weed invasion and more. Conversely, the application of too little water results in

tissue and cell damage due to salt accumulation predisposing the turf to damage from wear, disease, insect and weed invasion. Weather-based irrigation controls saves water usage and cost especially during the hot summer months.

4. FUTURE SCOPE

Laser can be used in the future to kill the bugs. This system will need very low power. An infrared beam may be able to track the bugs and a 3 - watt, 532-nanometer-wavelength green laser can kill the bugs. The killer beam blinds the system. The tracking laser can be used to count the frequency of the wing beats. The point of such a laser system is not to kill vast numbers of bugs but merely to fence them out of a particular patch.

REFERENCES

1. Chikaire, J. Nnadi, F.N., Nwakwasi, R.N., Anyoha, N.O, Aja O.O., Onoh, P.A., and Nwachukwu C.A. (2010), "Solar Energy Applications for Agriculture". Journal of Agricultural and Veterinary Sciences, Volume 2, September 2010.
2. Masami Shimoda and Ken-ichiro Honda (2013), "Insect reactions to light and its applications to pest management." Applied Entomology and Zoology 48.4 (2013): 413-421.
3. Shimoda, M. & Honda, K. Appl Entomol Zool (2013), "Insect reactions to light and its applications to pest management", Applied Entomology and Zoology, November 2013, Volume 48, Issue 4, pp 413-421
4. Nichanant Sermsri, Chonmapat Torasa (2014), "Colour Lighting Efficiency of Light Emitting Diode Tube To Lure the Adult Coconut Hispine Beetle". World Academy of Science, Engineering and technology, International Journal of Biomolecular, Agricultural, Food and Biotechnological Engineering Vol:8, No:9,2014.
5. Dr. S. Thangalakshmi, R. Ramanuja(2015), "Electronic Trapping and Monitoring of Insect Pests troubling Agricultural Fields", International Journal of Emerging Engineering Research and Technology Volume 3, Issue 8, August 2015, PP 206-213
6. Lee Cohnstaedt, Jonathan I. Gillen and Leonard E Munstermann, "Light-Emitting Diode Technology Improves Insect Trapping", US National Library of Medicine National Institutes of Health, December 2015
7. L.Harsha Vardhan Reddy V.Ashok Kumar Reddy S.Hemant P.J.Durga Prasad(2015), "Modelling and Optimization of Solar Light Trap For Reducing and Controlling", The Pest Population International Journal of Engineering Technology, Management and Applied Sciences April 2015, Volume 3 Issue 4, ISSN 2349-4476 224
8. Burkett DA, Butler JF, Kline DL' " Field evaluation of colored light-emitting diodes as attractants for woodland mosquitoes and other diptera in north central Florida", J Am Mosq Control Assoc. 1998;14(2):186-195.