

## Social Internet of Vehicles

Sakhil P George<sup>1</sup>, Nivya Wilson<sup>2</sup>, Krishnapriya U Nair<sup>3</sup>, Kareeshma Michael<sup>4</sup>, Mayble B Aricatt<sup>5</sup>,  
Thomas George K<sup>6</sup>

<sup>1</sup>Dept.of CSE, Jyothi Engineering College, Kerala, India

<sup>2</sup>Dept.of CSE, Jyothi Engineering College, Kerala, India

<sup>3</sup>Dept.of CSE, Jyothi Engineering College, Kerala, India

<sup>4</sup>Dept.of CSE, Jyothi Engineering College, Kerala, India

<sup>5</sup>Dept.of CSE, Jyothi Engineering College, Kerala, India

<sup>6</sup>Professor, Dept.of Computer Science Engineering, Jyothi Engineering College, Kerala, India

\*\*\*

**Abstract** - *The main vision of the Internet of Things (IoT) is to equip real-life physical objects with computing and communication power so that they can interact with each other for the social good. As one of the key members of IoT, Internet of Vehicles (IoV) has seen steep advancement in communication technologies. Now, vehicles can easily exchange safety, efficiency, infotainment, and comfort-related information with other vehicles and infrastructures using vehicular ad hoc networks (VANETs). We leverage on the cloud-based VANETs theme to propose cyber physical architecture for the Social IoV (SIOV). SIOV is a vehicular instance of the Social IoT (SIoT), where vehicles are the key social entities in the machine-to-machine vehicular social networks. We have identified the social structures of SIOV components, their relationships, and the interaction types. We have mapped VANETs components into IoT-A architecture reference model to offer better integration of SIOV with other IoT domains. We also present a communication message structure based on automotive ontologies, the SAE J2735 message set, and the advanced traveler information system events schema that corresponds to the social graph. Finally, we provide the implementation details and the experimental analysis to demonstrate the efficacy of the proposed system as well as include different application scenarios for various user groups.*

**Key Words:** *Social network of vehicles, Cyber-physical systems, Internet of Things, Internet of Vehicles, IoT architecture reference model, Intelligent transport systems, SAE J2735.*

### 1. INTRODUCTION

The growing technological advancements in the field of information technology have made Smart Cities a thing of near future. In a Smart City, all objects would have embedded processors and capability to communicate with each other through wired or wireless connections. These increasingly

intelligent objects would provide safe and convenient environment through increased interconnection and interoperability, which is also termed as Internet of Things (IoT). Within the objectives of IoT, vehicles play an important role for safe and convenient travel that leads to Internet of Vehicles (IoV).

The number of vehicles has increased dramatically in recent times. Almost all major cities experience heavy traffic during peak hours. An unfortunate accident or even a small road maintenance task can cause a huge traffic jam and further accidents. In US alone, more than 16,000 crashes take place every day on highways. Driver fatigue and lack of early warning system is responsible for these crashes. Watchful suggestions from the surrounding vehicles could be vital in these cases to provide improved safety to the vehicle users.

State-of-the-art vehicles are equipped with advanced technologies that enable them to communicate with nearby vehicles by forming vehicular ad-hoc networks (VANETs). There has been growing interest in building vehicular social network (VSN) where passengers can engage into entertainment, utility, and emergency related data exchanges. This type of social network belongs to the mobile social network (MSN) category where mobile users share user centric information with each other using mobile devices.

### 2. RELATED WORKS

Paper [1] implements on-board diagnostic and GPS on VANET to save the vehicle. In this paper, we use the communication of intravehicular and V2V to enable the safety of the vehicle. We extracted the vehicle information by connecting the OBD system using Pad's Bluetooth interface. And a WIFI connection enables the Pad to present a GUI for anti-collision warning, which is based on an offline map to show the real time GPS information of vehicles. Furthermore, we used the system board which supported the IEEE 802.11p/1609.X protocols to make information exchanged

in vehicles. And the LTE module enables a remote server to monitor all vehicles on the road.

We encapsulate the position and vehicle status information from Global Positioning System (GPS) and On-Board Diagnostic (OBD) to inform surrounding vehicles through CCH in real time. Furthermore, we develop the simple test platform to a set of the complete system for vehicular networking. A user interface combined with the safety information is designed and realized to show the efficiency for the safer driving.

Paper [2] develops an approach of IOV for smart and safe driving. In this paper we specify, connected vehicle architecture solutions for both safe and smart driving in personal or public vehicles. The idea is to utilize Internet of vehicle's dashboard camera (Smart-Eye) to enhance the control and accident prevention or monitoring services. The smart-Eye has capability to capture and share their real-time accident or traffic footage into text, audio and video forms to the related authorities such as nearest vehicles, police staff, hospital, family members and insurance company instantly along with the location. Hence, the Smart-Eye solutions can support automotive markets for smart and safe driving.

Paper [3] is vehicle anti-theft tracking system based on Internet of Things (IoT), which can provide all-round active service for the owners. This system is controlled by an RFID module to switch on and off. When the car is stolen, the vibration sensors and pyroelectric infrared sensors mounted inside the vehicle are triggered, and GSM module will send the location information obtained by GPS module to the owner's mobile phone, thus owners can check the position of the vehicle with an android software developed by our team. This system uses android mobile phones as mobile terminal, which is more convenient and flexible than other kinds of like products since the owner can check and track the position of the car immediately with android mobile phone application once the car is stolen.

Paper [4] is software defined networking for RSU clouds in support of the Internet of Vehicles. In this paper, a Roadside Unit (RSU) Cloud, a vehicular cloud is proposed as the operational backbone of the Vehicle Grid in the Internet of Vehicles (IoV). The architecture of the proposed RSU Cloud consists of traditional and specialized RSUs employing Software Defined Networking (SDN) to dynamically instantiate, replicate and, or migrate services. We leverage the deep programmability of SDN to dynamically reconfigure the services hosted in the network and their data forwarding information to efficiently serve the underlying demand from the Vehicle Grid. We then present a detailed reconfiguration

overhead analysis to reduce reconfigurations, which are costly for service providers.

Paper [5] is on adding the social dimension to the Internet of Vehicles : Friendship and Middleware. In this paper, we analyze the combination of Vehicular Ad-hoc NETWORKS (VANETs) with the Social Internet of Things (SIoT), i.e., the Social Internet of Vehicles (SIoV). In the SIoV every vehicle is capable of establishing social relationships with other vehicles in an autonomous way with the intent of creating an overlay social network that can be exploited for information search and dissemination in VANET applications. The contribution of this paper is two-fold: firstly, we define some relationships which can be established between the vehicles and between the vehicles and the road side units (RSUs); secondly, we propose a SIoV middleware which extends the functionalities of the Intelligent Transportation Systems Station Architecture (ITS SA), defined by ISO and ETSI standards, to take into account the elements needed to integrate VANETs in the SIoT. Additionally, we present results of software simulations analyzing realistic vehicular mobility trace in order to study the characteristics of the resulting social network structure.

Vehicular Ad-hoc NETWORKS (VANETs) are particular Mobile Ad-hoc NETWORKS (MANETs) in which nodes can be mobile or static. Mobile nodes are vehicles while static nodes are road-side units (RSUs). In VANETs, the vehicles are equipped with an On-Board Unit (OBU) through which they can communicate with other vehicles (Vehicle-to- Vehicle or V2V communication) and with RSUs (Vehicle-to- Infrastructure or V2I communication) by employing wireless short-range protocols as IEEE 802.11p. Furthermore, the vehicles and/or the RSUs can be able to connect to the Internet by using mobile cellular systems.

Paper [6] is Mobile tracking system using open MTC platform. This paper proposes new approach on managing all vehicle data using Machine-to-Machine (M2M) communication form which Open Machine Type Communication (OpenMTC) as communication platform for aggregating and processing location data. As a result, the testing showed high accuracy level in transmitting the vehicles position and it can be showed in many devices. Mobile tracking system is used to monitor vehicles position and in special cases there are much useful information can be monitored such as speed, cabin temperature and number of passenger. This monitoring process is done using vehicle's position data from satellite through GPS device, and sending the data to a server through GSM modem. The aim of this new approach, by combining mobile tracking system and

M2M OpenMTC platform technology, is to build a scalable system that can be easily adaptable to large scale Smart Systems using M2M technology. This paper presents the work of implementing mobile tracking system that utilizes M2M communication principles. The aim of the work is to verify the efficiency of using openMTC platform in supporting Smart Cities applications such as mobile tracking system.

Paper [7] provides reliable routing for road side to vehicle communication. In this paper, we study reliable routing for Roadside to Vehicle (R2V) communications in rural areas where rough terrain poses additional challenges. We propose a novel routing protocol where the stationary APs play a key role in route maintenance. The protocol includes a prediction algorithm which can predict the lifetimes of wireless links with consideration for terrain effects, as well as routing algorithms which can find stable paths for packet forwarding based on the prediction. Simulation results based on OPNET Modeler and the rural roadways in the Yellowstone National Park show that the proposed protocol substantially outperforms existing ad-hoc routing protocols.

Paper[8] based on Internet of Vehicles (IoV), provides distributed transport fabric capable to make its own decisions about driving customers to their destinations. Recent advances in communications, controls and embedded systems have changed this model, paving the way to the Intelligent Vehicle Grid. The car is now a formidable sensor platform, absorbing information from the environment (and from other cars) and feeding it to drivers and infrastructure to assist in safe navigation, pollution control and traffic management. The next step in this evolution is just around the corner: the Internet of Autonomous Vehicles. Pioneered by the Google car, the Internet of Vehicles will be a distributed transport fabric capable to make its own decisions about driving customers to their destinations. Like other important instantiations of the Internet of Things (e.g., the smart building), the Internet of Vehicles will have communications, storage, intelligence, and learning capabilities to anticipate the customers' intentions. The concept that will help transition to the Internet of Vehicles is the Vehicular Cloud, the equivalent of Internet cloud for vehicles, providing all the services required by the autonomous vehicles. This article is about the evolution from Intelligent Vehicle Grid to Autonomous, Internet-connected Vehicles, and Vehicular Cloud.

In paper [9], communication is used as a Service for Cloud VANETs. This paper proposes a cloud Communication as a Service (CaaS) to: a) enable a continuous communication to

vehicle located beyond the area uncovered by Roadside units; b) guarantee the Quality of Service QoS (QoS) in terms of delay, throughput and packet loss rate; and c) cope with resources limitation in vehicular networks. To implement these solutions, a Vehicular Cloud architecture (V-Cloud) which is composed by three layers, is proposed. The first layer, entitled Vehicular Cloudlet, consists of a set of vehicles connected to the network and organized into groups, creating a tree topology. The second layer, named Roadside Cloudlet, is a local cloud established among a set of neighboring RSUs. Finally, the third layer is the central cloud which is a cloud established among a group of servers in the Internet.

Paper[10] is about the connected vehicles and its solutions and challenges. This paper provides various wireless connectivities for vehicles enables the communication between vehicles and their internal and external environments. Such a connected vehicle solution is expected to be the next frontier for automotive revolution and the key to the evolution to next generation intelligent transportation systems (ITSs). Moreover, connected vehicles are also the building blocks of emerging Internet of Vehicles (IoV). Extensive research activities and numerous industrial initiatives have paved the way for the coming era of connected vehicles. In this paper, we focus on wireless technologies and potential challenges to provide vehicle-to-x connectivity. In particular, we discuss the challenges and review the state-of-the-art wireless solutions for vehicle-to-sensor, vehicle-to-vehicle, vehicle-to-Internet, and vehicle-to-road infrastructure connectivities.

### 3. DESIGN

The architecture of our system is shown in figure 1. An increasing number of social network applications is being proposed for vehicular networks, which leads to a shift from traditional vehicular networks toward SIoV. The architecture diagram consist of a motor driver which is connected to two motors. We use raspberry pi as our control system. We have breath analyser, piezo sensor, speed sensor, camera, and also the cloud server. All these are connected to the control system. The cloud server is used to store the encrypted datas of break, location, indicator, horn etc. Piezo sensor is used to convert the mechanical vibrations into the electrical signals. The breath analyzer is used for alcohol detection. Speed sensor senses the speed of the vehicle in rpm. Also we use GPS system in order to track the vehicle.

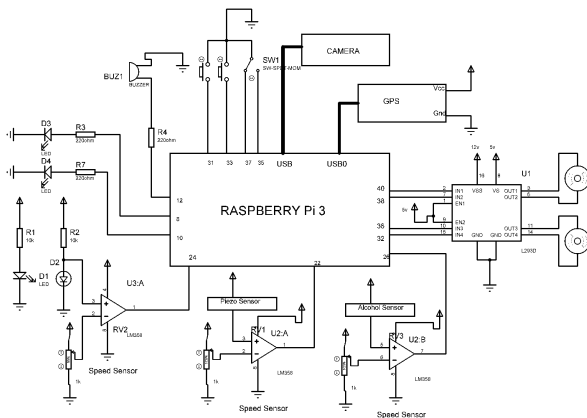

Fig-1:Circuit Diagram

## 4. TECHONLGIES & TOOLS

### 4.1 GPS Technology

GPS or Global Positioning System is a network of orbiting satellites that send precise details of their position in space back to earth. The signals are obtained by GPS receivers, such as navigation devices and are used to calculate the exact position, speed and time at the vehicles location. The GPS has been freely available to anyone with a GPS receiver. Airlines, shipping companies, trucking firms, and drivers everywhere use the GPS system to track vehicles, follow the best route to get them from A to B in the shortest possible time. The GPS is a "constellation" of approximately 30 well-spaced satellites that orbit the Earth and make it possible for people with ground receivers to pinpoint their geographic location. The location accuracy is anywhere from 100 to 10 meters for most equipment. Accuracy can be pinpointed to within one (1) meter with special military-approved equipment. GPS equipment is widely used in science and has now become sufficiently low-cost so that almost anyone can own a GPS receiver. The GPS is being used in science to provide data that has never been available before in the quantity and degree of accuracy that the GPS makes possible. Scientists are using the GPS to measure the movement of the arctic ice sheets, the Earth's tectonic plates, and volcanic activity.

### 4.2 Pieso sensor

A piezoelectric sensor is a device that uses the piezoelectric effect, to measure changes in pressure, acceleration, temperature, strain, or force by converting them to an electrical charge. Piezoelectric sensors are versatile tools for the measurement of various processes.

They are used for quality assurance, process control, and for research and development in many industries. Pierre Curie discovered the piezoelectric effect in 1880, but only in the 1950s did manufacturers begin to use the piezoelectric effect in industrial sensing applications. Since then, this measuring principle has been increasingly used, and has become a mature technology with excellent inherent reliability. Here we are using piezo sensor for accident detection. The vibration occurred during any accident is converted into the electrical signals. Based on piezoelectric technology various physical quantities can be measured; the most common are pressure and acceleration. For pressure sensors, a thin membrane and a massive base is used, ensuring that an applied pressure specifically loads the elements in one direction. For accelerometers, a seismic mass is attached to the crystal elements. When the accelerometer experiences a motion, the invariant seismic mass loads the elements. Sensors often tend to be sensitive to more than one physical quantity. Pressure sensors show false signal when they are exposed to vibrations. Sophisticated pressure sensors therefore use acceleration compensation elements in addition to the pressure sensing elements. By carefully matching those elements, the acceleration signal is subtracted from the combined signal of pressure and acceleration to derive the true pressure information. Vibration sensors can also harvest otherwise wasted energy from mechanical vibrations. This is accomplished by using piezoelectric materials to convert mechanical strain into usable electrical energy.

### 4.3 Breath analyzer

A breathalyzer or breathalyser (a portmanteau of *breath* and *analyzer/analyser*) is a device for estimating blood alcohol content (BAC) from a breath sample. Breathalyzer is the brand name (a genericized trademark) for the instrument that tests the alcohol level developed by inventor Robert Frank Borkenstein. It was registered as a trademark on May 13, 1954, but many people use the term to refer to any generic device for estimating blood alcohol content . Breath analyzers do not directly measure blood alcohol content or concentration, which requires the analysis of a blood sample. Instead, they estimate BAC indirectly by measuring the amount of alcohol in one's breath. Two breathalyzer technologies are most prevalent. Desktop analyzers generally use infrared spectrophotometer technology, electrochemical fuel cell technology, or a combination of the two. Hand-held field testing devices are generally based on electrochemical platinum fuel cell analysis and, depending upon jurisdiction, may be used by

officers in the field as a form of "field sobriety test" commonly called PBT (preliminary breath test) or PAS (preliminary alcohol screening) or as evidential devices in POA (point of arrest) testing.

#### 4.4 Speed sensor

Speed sensors are machines used to detect the speed of an object, usually a transport vehicle. Here we are using wheel speed sensor. A wheel speed sensor or vehicle speed sensor (VSS) is a type of tachometer. It is a sender device used for reading the speed of a vehicle's wheel rotation. It usually consists of a toothed ring and pickup. Wheel speed sensors are in anti-lock braking systems in conjunction with the Electronic Stability Program(Control) system.

#### 4.5 Data logging

A data logger (also datalogger or data recorder) is an electronic device that records data over time or in relation to location either with a built in instrument or sensor or via external instruments and sensors. Increasingly, but not entirely, they are based on a digital processor (or computer). They generally are small, battery powered, portable, and equipped with a microprocessor, internal memory for data storage, and sensors. Some data loggers interface with a personal computer, and use software to activate the data logger and view and analyze the collected data, while others have a local interface device (keypad, LCD) and can be used as a stand-alone device. Data loggers vary between general purpose types for a range of measurement applications to very specific devices for measuring in one environment or application type only. It is common for general purpose types to be programmable; however, many remain as static machines with only a limited number or no changeable parameters. Electronic data loggers have replaced chart recorders in many applications. One of the primary benefits of using data loggers is the ability to automatically collect data on a 24-hour basis. Upon activation, data loggers are typically deployed and left unattended to measure and record information for the duration of the monitoring period. This allows for a comprehensive, accurate picture of the environmental conditions being monitored, such as air temperature and relative humidity.

#### 4.6 Telegram application

Telegram is a free cloud-based instant messaging service. Telegram clients exist for both mobile (Android, iOS, Windows Phone, Ubuntu Touch) and desktop systems (Windows, macOS, Linux) Users can send messages and exchange photos, videos, stickers, audio, and files of any type. Telegram also provides optional end-to-end-encrypted messaging. Its client-side code is open-source software, whereas its server-side code is closed-source and

proprietary. The service also provides APIs to independent developers. In February 2016, Telegram stated that it had 100 million monthly active users, sending 15 billion messages per-day.

The security of Telegram has faced notable scrutiny; critics have argued that Telegram's security model is undermined by its use of a custom-designed encryption protocol that has not been proven reliable and secure, and by not enabling secure conversations by default.

## 5. IMPLEMENTATION DETAILS

### 5.1 Raspberry Pi 2

We have used an Raspberry PI 2 as our main pcb The Raspberry Pi 2 delivers 6 times the processing capacity of previous models. This second generation Raspberry Pi has an upgraded Broadcom BCM2836 processor, which is a powerful ARM Cortex-A7 based quad-core processor that runs at 900MHz. The board also features an increase in memory capacity to 1Gbyte. which have the following specifications.

Chip Core architecture CPU GPU Memory Operating System Dimensions Power Broadcom BCM2836 SoC Quad-core ARM Cortex-A7 900 MHz Dual Core VideoCore IV Multimedia Co-Processor Provides Open GL ES 2.0, hardware-accelerated OpenVG, and 1080p30 H.264 high profile decode Capable of 1Gpixel/s, 1.5Gtexel/s or 24GFLOPs with texture filtering and DMA infrastructure 1GB LPDDR2 Boots from Micro SD card, running a version of the Linux operating system 85 x 56 x 17mm Micro USB socket 5V, 2A

### 5.2 HLK-RM04 (*The WIFI Module*)

HLK-RM04 is a new low-cost embedded UART-ETH-WIFI module (serial port - Ethernet -Wireless network) developed by Shenzhen Hi-Link Electronic co., Ltd. This product is an embedded module based on the universal serial interface network standard, built-in TCP / IP protocol stack, enabling the user serial port, Ethernet, wireless network (wifi) interface. Through the HLK-RM04 module, the traditional serial devices do not need to change any configuration, data can be transmitted through the Internet network. Provide a quick solution for the user's serial devices to transfer data via Ethernet.

## 6. CONCLUSION

We propose a system that enables communication between vehicles. It provide safe driving by passing notifications to the vehicles, and provides remote driving, similar to google car. Driver can operate the vehicle from a remote location. We provides security to vehicles by storing details in the cloud server and during that time it will also prevents the misuse of this stored data by using encryption technique. Our system is better enough to solve social problems like robbery of

vehicles. During robbery's the details regarding the vehicle such as location and all other informations are sent to the cyber cell, hence cyber cell can track and lock the vehicle, then the vehicle became stationary. The complete details of the vehicle is stored in the cloud server, so when an accident is happens the police can take action in correct way. At the same time GPS value is sent to ambulance, so it allows ambulance facility on time. In our system, the vehicles are equipped with advanced technologies, that enable them to communicate with nearby vehicles by forming vehicular ad-hoc networks. Our system is used to reduce accidents, alcohol detection and it protect vehicles from collision and theft. In our system, the data is highly protected. It uses different sensors so that it can measure the distance between the vehicles and also monitor road collisions and provides safe driving.

### ACKNOWLEDGEMENT

First and foremost, we express our thanks to The Lord Almighty for guiding us in this endeavour and making it a success. We take this opportunity to express our heartfelt gratitude to all respected personalities who is guided, inspired and helped us in the completion of this work.

### REFERENCES

- [1] Zhen Qin, Zhen Meng, Xiaoyi Zhang, Bin Xiang, and Lin Zhang. Performance Evaluation of 802.11p WAVE System on Embedded Board[C]//International Conference on Information Networking(ICOIN), 2014 IEEE.
- [2] Junping, Z., Fei-Yue, W., Kunfeng, W., Wei-Hua, L.,Xin, X., Cheng, C., "Data-Driven Intelligent Transportation Systems: Survey", IEEE Transactions on Intelligent Transportation Systems, Vol. 12 (4) pp. 1624-1639, 2011.
- [3] H. Song, S. Zhu, and G. Cao, "Svats: A sensor-network-based vehicle anti-theft system," IEEE INFOCOM 2008, pp.2128-2136, April.2008.
- [4] A. Zanella, N. Bui, A. Castellani, L. Vangelista and M. Zorzi, "Internet of Things for Smart Cities," IEEE Internet of Things Journal, vol. 1, no. 1, pp. 22-32, 2014.
- [5] G. Dimitrakopoulou, "Intelligent transportation systems based on internet-connected vehicles: Fundamental research areas and challenges", in Proc. of the 11<sup>th</sup> Int. Conf. on ITS Telecommunications (ITST), Aug. 2011, pp. 145-151.
- [6] Shahriyar, R, dkk (2009): "Intelligent Mobile Health Monitoring System (IMHMS). International Journal of Control and Automation. Vol 2. No. 3.
- [7] IEEE 802.11 Working Group, Wireless LAN Medium Access Control (MAC) and Physical Layer (PHY) Specifications, IEEE Standard, 1997.
- [8] U. Lee, E. Magistretti, B. Zhou, M. Gerla, P. Bellavista, and A. Corradi, "MobEyes: Smart Mobs for Urban Monitoring with a Vehicular Sensor Network," IEEE Communications Magazine, vol. 13(6), pp. 52 – 57, Oct. 2006.
- [9] R. Yu, Y. Zhang, S. Gjessing, W. Xia, and K. Yang, "Toward cloud-based vehicular networks with efficient resource management," IEEE Network, vol. 27, no. 5, pp. 48 – 55, October 2013.
- [10] Transparency Market Research, "Connected car market—Global industry analysis, size, share, growth, trends and forecast, 2013–2019," Transparency Market Res., Albany, NY, USA, 2013.