

Dish Positioning By Using IR Remote

Prof. S. A Maske¹.Mr. Shelake Aniket Vishwasrao ².

Mr.Shinde Anup Sanjay³ . Mr. Mugade Nitin Krushnat ⁴.

Sanjeevan Engineering Institute & Technology, Panhala ,Department of E&TC

Abstract- *In this paper, microcontroller was designed to develop a dish positioning system which can be operated by using a remote control. The main point of using a dish is to receive signal from satellites and other broadcasting sources. In order to get the exact angle of position of the dish, it needs to be adjusted manually. In order to overcome the difficulty of adjusting manually, this paper helps in adjusting the position of the dish through a remote control. Remote control acts as a transmitter whose data is received by an IR receiver which is interfaced to a microcontroller. The remote control sends coded data to the receiver whose output is then sent to the microcontroller. Basic pro language is also used to implement this system. The microcontroller sends the control signals to the motor through an interface known as relay driver.*

Keywords – Microcontroller, Infrared(IR) Remote Control, DC Motor of the Dish .

1. INTRODUCTION

The project is designed to develop a dish positioning system which can be operated by using a conventional TV remote. The main application of using a dish is to receive signal from satellites and other broadcasting sources. In order to position the dish to the exact angle to receive the maximum signal of a particular frequency, it needs to be adjusted manually.

In order to overcome the difficulty of adjusting manually, this proposed system helps in adjusting the position of the dish through a simple TV Remote. This system consists of two motors that enable the dish to move both in horizontal and vertical direction.

The TV remote acts as a transmitter whose data is received by an IR receiver which is interfaced to a microcontroller of 8051 family. The TV remote sends

coded data to the receiver whose output is then sent to the microcontroller. The microcontroller sends control signals to the motors through an interface IC also known as motor driver IC.

The code followed by the TV remote is a standard RC5 code. This code is used in the program to recognize the input code from the TV remote for the controller to develop appropriate output signal for the motor driver IC. Further the project can be enhanced by using RF control instead of IR which has got line of sight communication restrictions.

2. LITERATURE REVIEW

Richard, V., Editor, "Motor Control Electronics Handbook, Mc Graw-Hill, Boston. Nowadays, the most popular motor is a servo motor that is used to control and drive for heavy load application. On the other hand, the servo motor cost is extensively high for this application. [10]

Chatterjee S., "Industrial Electronics and Control", New Delhi: Tata Mc Graw-Hill Publishing Company Limited. Using the remote control improves the advanced technology. And using the microcontroller develops the motor to maintain the desired position. Although this is the first approaching step to the control system, automation system and robotics systems, these can greatly serve to the industrial control. [9]

3. PROBLEM DEFINATION

Satellite dish positioning system can be provided with computer system without microcontroller. But microcontroller is a single chip it is low cost, small size and high performance. So, microcontroller is most suitable for auto positioning system. In this system, a satellite positioning system has been developed.

A dish control system is critical to its tracking capability. Dish are controlled the manual operation which is time consuming and less accurate. This system is used remote control to start the motor moving in the desired direction. Microcontrollers are widely used all over the world and it is based on the latest technologies.

Using the remote control improves the advanced technology. And using the microcontroller develops the motor to maintain the desired position. Although this is the first approaching step to the control system, automation system and robotics systems, these can greatly serve to the industrial control.

4. BLOCK DIAGRAM

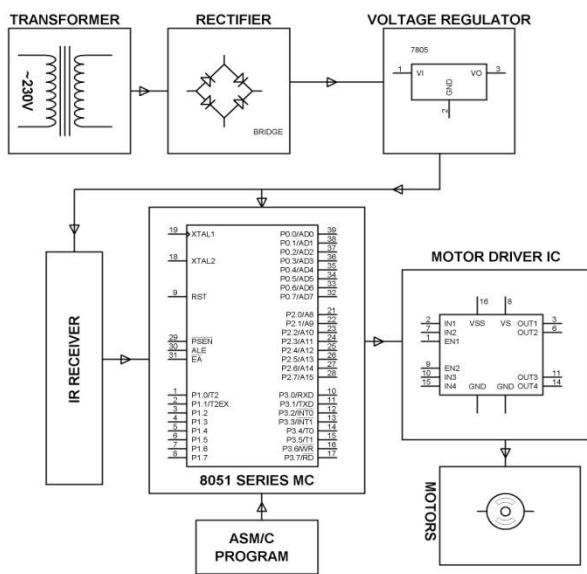

Fig1- System Architecture of The Proposed Embedded Web Server

5. CONCEPTUAL ARCHITECTURE

This proposed architecture is divided into 3 parts: Remote environment; Aurdino UNO & home internet connectivity shown in figure. A vision that is being implemented by many in the world is an extensive range of everyday objects connected and communicating cheaply with each other across a global network - "the Internet of Things." The electronic devices in our world

generate enormous amounts of data and thanks to the Internet the possibilities for interaction between devices is almost endless. These devices can be data sources (sensors), end user devices (displays, databases), and even a data source and sink (an actuator, smart phone). Using the Internet for weather monitoring raises new issues and there are remaining implementation limitations. Internet communications are scalable and can be used to connect to everything in a weather monitoring network.

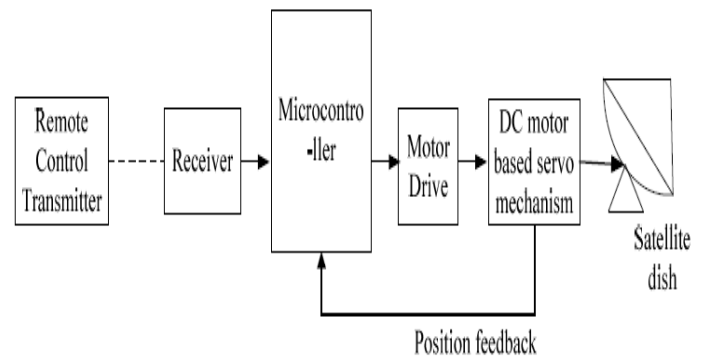

Fig2. Conceptual Architecture

Firstly, the motor is reaching in something degree when the power supply on. This degree is called the last degree. If the setting switch is pressed to save degree and count of the motor of the satellite dish, motor will go to the lowest limit from current degree. After reaching to the lowest limit, the motor will stop. We get zero degree and zero count.

Then the motor will go to the highest limit. After reaching the highest limit, the motor will stop. And then, the maximum degree is saved in the microcontroller.

So the maximum degree and maximum count are got. Microcontroller calculated resolution and saved the degrees and pulses in EEPROM. When command degree from remote control fed to the microcontroller, the motor is driven. The motor is driving with the counts. These counts are being sensed by sensor.

Sensor feedback counts of driving motor to the microcontroller. Microcontroller makes increasing the counts if the command degree is greater than the last degree. While increasing the counts, the motor will be

stopped by microcontroller when the command degree is equal to the last degree.

Similarity, microcontroller makes decreasing the counts if the command degree is less than the last degree. While decreasing the counts, the motor will be stopped by microcontroller when the command degree is equal to the last degree.

6. DESIGN IMPLEMENTATION

FLOW CHART for WEBSERVER

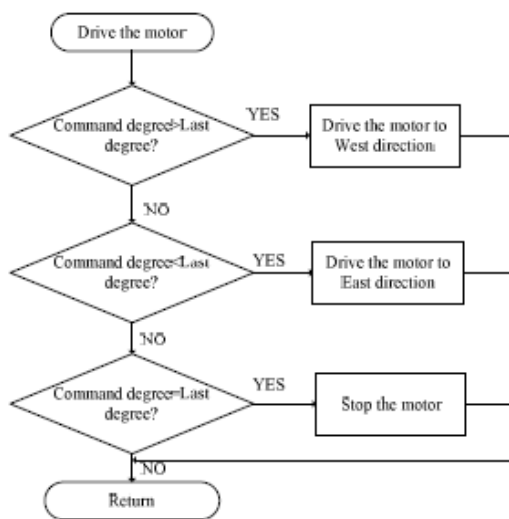

Microcontroller is used to drive the motor to the clockwise direction when the command degree is greater than the last degree and counterclockwise direction when the command degree is less than the last degrees in Figure.. And it is used to drive the motor with the desired degree by calculating the command degree from remote and feedback Degree from the reed sensor.

8. ADVANTAGES

The dish position, i.e., tuning, is very important for getting the standard-broadcast signals from the satellite. The dish must be pointed at a correct angle to get the strongest signal possible. If the dish position is adjusted manually, one cannot direct the dish towards the best possible position. This proposed system is intended to adjust the dish position through a simple TV remote by pressing the buttons corresponding to the direction of the

dish position.

9. RESULT

We are monitoring the change in angle of dish and make the perfect angle in right direction.

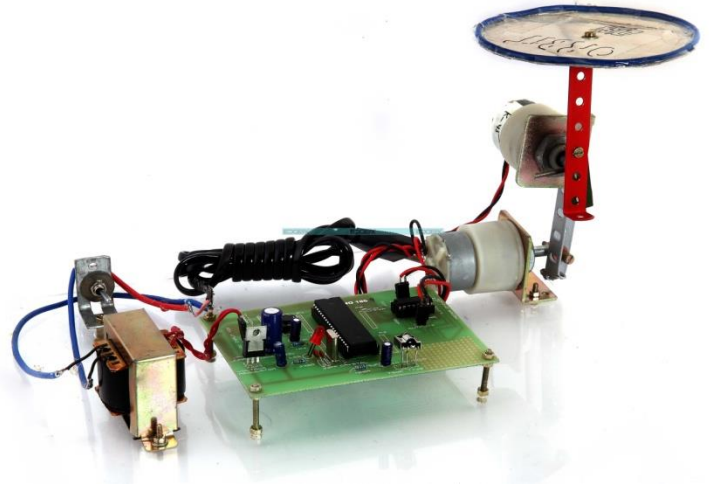

CONCLUSION

Microcontroller is most suitable for auto positioning system. In this system, a satellite positioning system has been developed.

A satellite dish control system is critical to its tracking capability.

This system is used remote control to start the motor moving in the desired direction. Microcontrollers are widely used all over the world and it is based on the latest technologies. Using the remote control improves the advanced technology. And using the microcontroller develops the motor to maintain the desired position. Although this is the first approaching step to the control system, automation system and robotics systems, these can greatly serve to the industrial control.

11. FUTURE SCOPE

We can interface more sensors and control processes. We have use to two sensors. Also to make it very simple it can be used just as just a monitoring system. We can provide SMS alerts.

12. REFERENCES

- [1] <<http://www.edgefxkits.com/dish-positionig-control-by-ir-remote>.
- [2] < <http://www.satsig.net/sslist.htm> "List of Satellite in Geostationary Orbit".
- [3] <<http://afarts.dodmedia.asd.mil/tech-info/downlink/Satellite Antenna -Alignment-Rev 1.pdf> and <<http://www.dishpointer.com/>.
- [4] <Microchip, PIC16F87XA, Data Sheet, DS39582B, Microchip Technology Inc, <http://www.microchip.com/downloads/en/DeviceDoc/39582b.pdf>.
- [5] Ian Aber, James Binney, Miles Buckman, Samantha Krening, Vu Nguyen, Michael Reher, and Miranda Rohlfing "Creating a Control and Operating System For Monitoring and Observing Space(COSMOS)".
- [6] Nhivekar G.S. and Mudholkar R.R. "Microcontroller Based IR Remote Control Signal Decoder for Home Application".
- [7] R. Krishnan, Electric Motor Drives, Low Price Edition.
- [8] <http://www.reed-sensor.com> Relay and Electronic India Limit info @ reedswitch.com.
- [9] Chatterjee S., "Industrial Electronics and Control", New Delhi: Tata Mc Graw-Hill Publishing Company Limited.
- [10] Richard, V., Editor, "Motor Control Electronics Handbook, Mc Graw-Hill, Boston.