

# SwaRma – A Women Safety Device

Anitha.k<sup>1</sup>, Kanimozhi.R<sup>2</sup>, Hemalatha.P<sup>3</sup>, Giridharan.S<sup>4</sup>

<sup>1&2</sup>UG Scholar, Department of Information Technology, IFET College of Engineering, Villupuram

<sup>3&4</sup>Assistant Professor Department of Information Technology, IFET College of Engineering, Villupuram

\*\*\*

**Abstract**— Nowadays Women's Safety has become a major issue due to their fear of violence, sex empowerment, etc. Women's in India facing many problems while travelling in a bus or any other vehicles. . Flush in the 21st period anywhere the knowledge is quickly mounting and new-fangled implements were established but still women and girls are facing problems. Women's cannot move out from home at night times and even in day time crowded areas also have many incidents are happen. For these issues our paper aims to design and develop a Smart GPS Watch with Smart Android App which will track the position of the attached person and also to monitor all sudden fall and Irregular Attacks. And also aims to create any number of predefined security zones within a campus area and other places.

**Keywords-** Smart phone, Android app, GPS watch, Flexi force sensor, MEMS Accelerometer

## I. INTRODUCTION

In today's world People at home are not sure of women's return safely back to their home. Among other crimes, rape is the fastest growing crime in the country today. All are knows about the Nirbhaya singh incident happened in New Delhi at night 9.30 PM which is a gang rape and this Act named as WARMA. And another more incidents are happened in Chennai, more specifically Swathi murder case. To overcome these problems the device "SwaRma" which is a flash warning giving an instant location of the distressed victim to the police and the parents so that the incident could be prevented and the culprit apprehended. Here why this paper named as SwaRma means combination of SWATHI+WARMA act="SWA-RMA". The device descried here is a self-defense system specially designed for women in distress to help them to protect themselves. The lady in danger can activate the system by pressing emergency button. It is a simple and easy to carry device with wide range of features and functionality. The basic approach is to intimate instant location and a distress message to the cops and registered number like parents, friends, broadcasting, and mankind chamber etc. so that unsuccessful instances would be

forestalled and to afford tangible time evidence for swift action against the perpetrators of crime against women.

## II. PROPOSED SYSTEM

The proposed system aims to design a economically feasible device and to create any number of predefined security zones within a campus area and other places which is not feasible with human securities and economically feasible. The smart watch tracks the person who wears it with the help of an integrated GPS and alerts the authority when the person crosses the virtual zone boundary using GSM and With Android Phone. The whole device just runs with total of 12v in which 5v is enough for the ARM to process. In this system, a GPS watch is used to find the location and send the location to the group of people stored in the Android Application. [1]The user can be sent the alert by using the SMS service available in the mobile phones. When the alert services is activated the user get the Current Latitude and Longitude from the GPS service available in the Smart phones, then the users get the Current location address from the latitude and longitude details. The proposed system [2] provides all required functionality and there is no need to buy and install different apps that possess different functionality. Hence the cost gets minimized as well as the memory requirement by the system is less compared to having many apps.

## III. Proposed System Architecture

Women tracking is mainly based on two units :

1. GPS watch unit and
2. Android monitoring unit.

The GPS watch unit contains a GPS receiver, Flexi Force Sensor, MEMS accelerometer. This timepiece entity is devoted to the arrows of the creature. Using the GPS mouthpiece we can observer the movement of the students and women.

This GPS receiver will work under the control of GPS satellite and then if the watch unit is removed or gets damaged the Flexi Vigor Beam will vigilant the authority with the help of Bluetooth Connection with Android App.

The GPS module tracks the longitude and latitude to smidgeon an particular position of a user and sends the pre-stored emergency message including location to the registered contact numbers.

This Flexi Force is available in the bottommost of the timepiece which varieties a clutch we can display while they confiscating the guard unit from the hand. MEMS accelerometer present in the watch unit is used for monitoring the sudden fall and Attack of the Women. This watch unit will send the signals to the Android monitoring unit with Bluetooth communication. The fig. 1 shows the watch unit.

If the scholar marks the given boundary contour the indicators will be guide to the watching element using the GPS receiver present in the GPS watch unit. The monitoring unit sends the signal via SMS to the authority using GSM cellular modem present in the Android Phone.

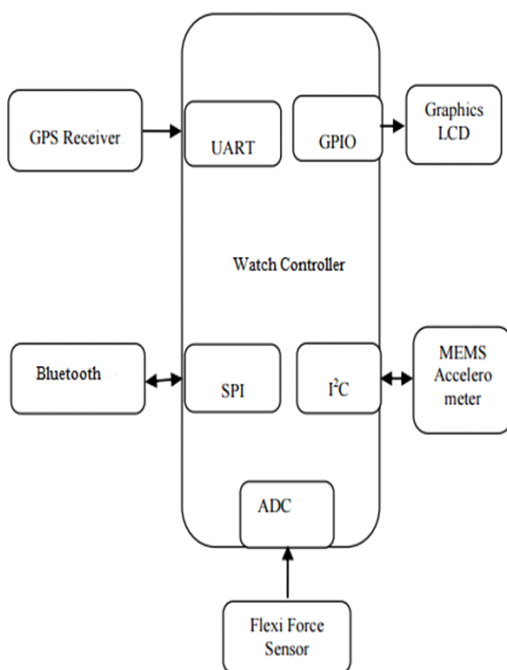

Fig 3.1: Watch unit

Removing the watch unit from the hand or gets damaged is prohibited. If it happens, it will alert the right using the Flexi Force Sensor. If the offspring go sequestered any precarious sector contemporaneous esoteric the school campus it can also be monitored using the GPS receiver. Sudden fall or Attack of the Women can also be monitored using GPS watch unit. It will send Help Request to Nearest Police Station With Special Android App. It provide women safety even in the situation like terrorist attacks [3] or

natural disaster, by just shaking the watch on the hand above the predefined threshold value automatically activate the system.

#### IV. PROPOSED SYSTEM METHDOLOGY

The coordination may perhaps be circumstance in moreover of the two approaches OUT and IN. In the OUT way, it helps school and college organization to prevent students from crossing an invisible fence that alarms school specialist by way of SMS when they consent the sector[3]. During the IN mode, the system could be used to prevent a student from reaching into a protected or dangerous area within the campus premises.

##### GPS Receiver

Subsequently this is a refuge coordination, GPS guard should be permanently committed to the examined creature and removing or damaging this device should be prohibited. This GPS receiver will work under the control of GPS satellite. The GPS module tracks the longitude and latitude to trace an exact location of a user and guides the pre-deposited substitute missive containing locality to the enumerated connection information.

##### Flexi Force Sensor

Flexi Vigor radar is devoted to the vertebral of the ruse and it intellects the grasp dynamism of the device with the user skin. The device will send an SMS to the authorities if the device gets altered or indifferent by any revenues. To deactivate this sanctuary latch article an sanctioned manipulator could simply press the enable-disable button in the central control unit using a **Keypad**.

##### MEMS Accelerometer

This system can also be applied in monitoring Ladies. When an ladies falls or Attacks, a 3-axis Digital **MEMS Accelerometer** sensor in the watch could sense this and alert the central unit via wireless communication which in turn will send SMS about the fall location to the necessary person or to the hospital. The system is used to track the student/Ladies who is within the radio communication range.

##### ARM Controller

Due to the low power nature of the device the wireless radio communication standard, **IEEE 802.15.4** is chosen for this project. More than one SMS can be sent if it has to. The system helps us to create any number of predefined security zones within a campus area. Number of security zones could

be increased. The device is battery powered and built with **LPC1313**, a 32-bit **ARM Cortex-M3** microcontroller from **NXP Semiconductors** (Inbuilt With Smartphones). It requires GPS receiver enabled watch. Location will be tracked using GPS. It finds the longitude and occasion of present position of handler. Using longitude and freedom whereabouts is explored and an actual address is given via message.

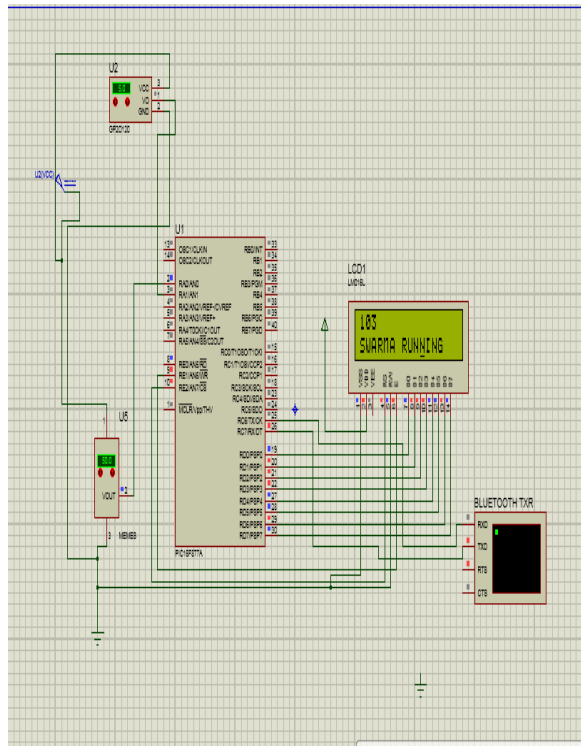

Fig 4.4 Circuit Diagram for SwaRma Device

In, the messages to the numbers [4] stored (numbers of friends, family and neighbors) in the android app, is an automatic message to a particular friend whose number is stored and directing situation of deceive to the adjoining Police department Location and other information which stowed in the succession of linkage. All these operation can be made by using a single push on a button. When the switch is pressed, GPS used to trace the dupe location. GPS receiver gets the site from satellite. The incoming signal consists of GPS coordinate. By compare this with the database the server will find out the corresponding place and guided evidence (missive and location) to those figures hold back along with that commercial. These quantities consist of Police station records of that constituency and others in that province so that they can return in the instance.

**V. CONCLUSION**

The projected proposal will compact with life-threatening problems challenged by womankind in the near past and will benefit to solve them with technologically. While the society may or may not change for the enhanced, the authority to be self-sufficient, self-guaranteed and strictly unrestricted can come with disarmament oneself with the best possible device. This system can overcome the fear that scares every woman in the country about her safety and security. This mobile application and watch are very much helpful for any woman. Because when a woman is in danger position the device will send the alert to their parents or friends.

**ACKNOWLEDGMENT**

I extremely grateful and convey my heartfelt thanks to my internal guide Professor Mrs.P.Hemalatha and Mr.S.Giridharan work under the Department of Information Technology IFET College of Engineering Villupuram, TN, for his valuable suggestions and encouragement throughout all the development stages of this paper.

**REFERENCES**

[1] *Women Safety Application using Android Mobile* N. Saranya M.C.A.1, Mr.KarthikMCA.2 PG Scholar1,Assistant Professor2 VSB Engineering College.

[2]*All in one intelligent safety system for women security* Abhijit Paradkar , ME Computer Engg student Deepak sharma associate professorK. J. Somaiya college of Engg., Vidyavihar, Mumbai, India .

[3]*Hierachy baased distributed scheduling Algorithm for mobile data Gathering in WSN* Palani.U, Alamelumangai.V, AlameluNachippan, IFET college of Engineering

[4] *one touch alarm system for women'ssafety using gsm*Premkumar.P1, CibiChakkaravarthi.R2,Keerthana.M3, Ravivarma.R4, Sharmila.T5 *Department of Electronics Instrumentation Engineering K.S.Rangasamy College ofTechnology, Tiruchengode (India)*

[5]*Application for Women Safety* 1S.Sangeetha, 2P.Radhika PG Scholar, Department of MCA, Panimalar Engineering College,TN.

[6] Nishant Bhardwaj and Nitish Aggarwal, "Design and Development of "Suraksha"-A Women Safety Device", Department of Electronics and Communication ITM UNIVERSITY Huda Sector 23-A Gurgaon Delhi India, ISSN 0974-2239 International Journal of Information & Computation Technology online available at <http://www.irphouse.com>, Volume 4, pp. 787-792, November 2014.

[7] Nicole Westmarland, Mariann Hardey, et al. *"Protecting Women"s Safety? The use of smartphone „apps“ in relation to domestic and sexual violence"*, Durham University, Durham centre for research into violence and abuse (2013).

[8] Mason, C and Shoshana Magnet, *"Surveillance studies and violence against women"*, *surveillance & society* 10(2):105 – 118 (2012).

[9] *An Intelligent Security System for Violence against Women in Public Places*. Remya George, Anjaly Cherian.V, Annet Antony, Harsha Sebastian, Mishal Antony, Rosemary Babu.T

[10] Ashokkumar Ramalingam, Prabhu Dorairaj and Saranya Ramamoorthy *"personal safety triggering system on android mobile platform"*

[11] THOOYAVAN V, *"advanced security system for women"*, Department of ECE Vidyaa Vikas College of Engineering and Technology Vasai Thane India, Final year project, Serial number HEM 128 IEEE 2014 Project List under real time target surveillance system, slides share on [www.slideshare.net](http://www.slideshare.net), Jun 24, 2014.

[12] *Women Safety Device and Application-FEMMED*. G. Monisha1\*, M. Monisha1, G. Pavithra2 and R. Subhashini31 Department of Information Technology, Sathyabama University, Chennai