

A Spring Loaded Flexible Bumper Controlled Automotive Braking

Rushikesh Ambadas Mule¹, Avinash Sunil Kasar², Monali Thombare³, Bilal Shaikh⁴

¹Rushikesh Ambadas Mule, Mechanical Engineering, SSM Adsul Polytechnic, Chas, A'nagar, Maharashtra, India

²Avinash Sunil Kasar, Mechanical Engineering, SSM Adsul Polytechnic, Chas, A'nagar, Maharashtra, India

³Professor Monali Thombare, Dept. of Mechanical Engineering, SSM Adsul Polytechnic, Chas, A'nagar, Maharashtra, India

⁴Professor Bilal Shaikh, Dept. of Mechanical Engineering, SSM Adsul Polytechnic, Chas, A'nagar, Maharashtra, India

Abstract – In almost all of the cases of vehicle accidents, the basic reason cited is failure to apply the brakes at the right time. Considering this failure, a mechanical system having spring loaded flexible bumper is designed. During obstacle, the spring is compressed to apply clutch and brake. A system consists of sensor, pneumatic bumper system and intelligent braking system, increases complications and its cost [1]. Proposed hardware system is simple and does not require any of these components. Through the testing, accuracy for the compression of spring is obtained. This paper presents well designed prototype of spring loaded flexible bumper controlled automotive braking system.

Key Words: Mechanical spring, bumper, automotive braking system

1. INTRODUCTION

Automobile vehicles have become integral part of our lives. With growing number of vehicles on road, the numbers of traffic accidents are also increasing. It is important to prevent the chances of accidents and to protect the passengers when accidents occur. Air bags provide safety, but they are costly. Safety, being a matter of prime importance, cannot be compromised for cost. Hence our attempt is to provide a reliable and safe system at low cost. Though there are different causes for these accidents but proper technology of braking system and technology to reduce the damage during accident can be effective on the accident rates. In today's world to prevent the accidents by vehicles, implementation of automatic braking system is must [2]. Therefore, pre-crashing system is demanded. Such a system will prevent accidents on road.

In conventional vehicles there are different mechanism operated for braking system like use of hydraulic, pneumatic, or mechanical system. But all these braking mechanisms get the input signal directly from the driver by application of force on brake pedal. Thus, braking of vehicles is totally manual operated. So, if the driver fails to see the obstacle in front of his driving vehicle or fails to apply proper braking force on the brake pedal, he may lose the control of his vehicle, leading to accident [3]. Also the driver may not able to pay complete attention when driving at night. So there are

many chances of accidents. Hence, there is no provision to minimize the damage of vehicles. Thus, the current designed system only fairly reduces the damage of vehicle and/or passengers [4].

2. MECHANICAL SPRING

Springs are mechanical elements that exert forces or torques and absorb energy. The stored absorbed energy is released later. Springs are made up of metal. Metal springs can be replaced by plastic springs in case of light loads. Structural composite materials are used by some applications which require minimum spring mass. Blocks of rubber can be used as springs, in bumpers and vibration mountings of electric or combustion motors. Figure 1 shows mechanical spring.



Fig -1: Mechanical spring

3. WORKING PRINCIPLE DESIGN & ANALYSIS

1.1 Construction of Project

Figure 2 shows actual diagram of project. The aim is to design and develop a spring controlled automotive braking system. Here flexible bumper is attached to the chassis of the vehicle by means of spring. Hence bumper gets compressed against spring force on the application of external force. Hence this bumper is called as flexible bumper because it gets pressed under the application of external force. Hence this bumper is pressed due to obstacle coming front of the vehicle. A link is used which is pivoted to the chassis and connected to the flexible bumper and link of brake pedal. In this prototype, the components such as sensor, pneumatic bumper system and intelligent braking system are replaced by a single spring. When obstacle comes

in front of vehicle then it compresses the spring loaded flexible bumper first and take some time to reach the actual chassis of vehicle. During this time interval, flexible bumper rod drags the brake and clutch pedal by means of spring and it actuate clutch and brake of the vehicle.



Fig -2: Construction of project

In this way, vehicle stops without actual contact with chassis. Hence collision is reduced by stopping the vehicle.

4. DESIGN & ANALYSIS

4.1 Spring

Our braking action can possible if bumper is moving 20 to 25 mm in the direction of chassis [5]. Hence for maximum displacement of spring (shown in figure 3) i.e. for $\delta_{max}=25\text{mm}$

$F_{max}=1200\text{N}$ can be generated by impact of human

Assuming Spring Index= $C=5$;

Spring Material:

$\tau = 400 \text{ N/mm}^2$

$G=85 \times 10^3 \text{ N/mm}^2$

Wire diameter:

Wahl factor $K_w = \frac{(4C-1)}{(4C-4)} + \frac{(0.615/C)}{(4C-4)}$

$= \frac{[(4 \times 5)-1]}{[(4 \times 5)-4]} + \frac{(0.615/5)}{[(4 \times 5)-4]}$

$= 1.3105$

Shear Stress Induced:

$\tau = K_w [8 F_{max} C / \pi d^2]$

$400 = [1.3105 \times 8 \times 1200 \times 5] / \pi d^2$

$d = 7.1\text{mm}$

Mean Coil Diameter:

$D = Cd$

$= 5 \times 7.1$

$= 35.5 \text{ mm}$

Taken $D = 40\text{mm}$

No. of coil turns:

Spring Stiffness, $K = F_{max} / \delta_{max}$

$= 1200 / 25 = 48\text{N/mm}$

Now, $K = Gd / 8C^3n$

$48 = (85 \times 10^3 \times 7) / (8 \times n \times 5^3)$

$n = 12.6$

Assuming square & ground ends,

Total no. of coils,

$n' = n + 2 = 14.6$

Spring length & pitch

Solid Length, $L_s = (n+2) d$

$= (12.6+2)7.1$

$= 103.66 \text{ mm}$

Free length = Solid length + Max. Deflection + Total Clearance

$= L_s + \delta_{max} + (n'-1)d$

$= 103.66 + 25 + (14.6-1)7.1$

$L_f = 142.26\text{mm}$

Now, $L_f = pn + 2d$

$142.26 = p(12.6) + (2 \times 7.1)$

$p = 10.16\text{mm}$

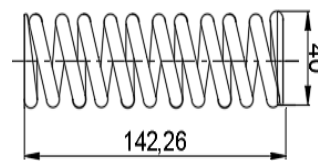

Fig -3: Spring

4.2 Frame

The Height of frame must be greater than the radius of wheel for proper rotation (Figure 4).

Hence Rad. Of wheel = 325 mm

Hence frame height selecting giving proper clearance between ground level = 350mm

Frame width at one end = 140mm which is near about less than the length of pedal rod.

Frame width at one end = 180mm which is near about less than the length of axle rod of the hub.

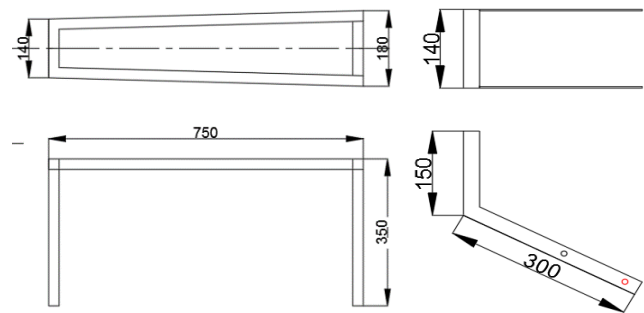

Fig -4: Frame and Flexible Bumper

5. LIST OF MATERIALS

Table -1: List of materials [6]

Sr. No.	Description	Material	Quantity
1	Wheel	STD	01
2	Link	Steel	01
3	Link	STD	01
4	Flexible Bumper	MS	01
5	Spring	Steel	01
6	Frame	MS	01
7	Brake Pedal	STD	01

5.3 Cost of Equipment

Table -1: Material Cost

Sr. No.	Name of component	Specification	QTY.	Cost
01	Wheel with Drum	325 mm dia.	01	450
02	Tyre	3300 mm dia.	01	120
03	Brake shoe with link		01	350
04	Axle	200mm long	01	80
05	Bearing for wheel hub		02	160
06	L channel (Angle)	1" and 15 feet	01	420
07	Sheet metal	0.5 mm thick perforated	01	40
08	Pivot rod	200mm long	02	80
TOTAL				1700

Table -1: Manufacturing Cost

Sr. No.	Manufacturing	Time	Cost
01	Frame	80 min.	510
02	Bumper	40 min.	230
03	Assembly	10 min.	30
TOTAL			770

6. ADVANTAGES

1. It avoids unnecessary movement of bumper as it activates only when obstacle compresses the flexible bumper of vehicle.
2. It does not require any proximity sensor which is costly.
3. It does not require any intelligent braking system to stop the vehicle when bumper is activated.
4. It does not require any Compressor for activating the bumper.
5. Overall cost & size becomes low due to absence of sensor, intelligence braking system, pneumatic system with compressor.

6.1 Limitations

1. System has very few limitations in densely traffic road.
2. To avoid total accident, system must be situated at both sides of the vehicle.
3. Time interval require for obstacle to compress flexible bumper and chassis must be as high as possible.

6.2 Applications

1. Three wheeler & four wheeler can use this to avoid damage of vehicle body & human due to accident from obstacle coming from the front of vehicle.

2. Heavy vehicles like buses, trucks, trailers etc. can also successfully use this system.

7. CONCLUSIONS

With limited knowledge, an excellent opportunity and experience has provided by this paper. This paper introduces a system which is totally mechanical and apply the clutch and brake when obstacle compress the spring loaded flexible bumper. The Overall cost & size is lowered due to absence of sensor, intelligence braking system, and pneumatic system with compressor.

REFERENCES

- [1] Srinivasa Chari.V, Dr.Venkatesh P.R, Dr.Prasanna Rao N.S, Adil Ahmed S, "Automatic Pneumatic Bumper And Break Actuation Before Collision", IRJET, 04| July-2015
- [2] Sammed M Kesti, Dhanaanjaykumar J Upadhye, Sumeet A Bastawade and Wadkar Rasik Adinath, "Design And Fabrication Of Automatic Pneumatic Bumper And Braking System For Four Wheeler", ISRASE
- [3] Mr. Nivesh Thepade, Mr. Lakhan Thombare, Mr. Pritish Varude, Prof. Ashish Umbarkar, "Intelligent Braking System with Automatic Pneumatic Bumper", IJSRD, 04, 2016
- [4] Dr. Kripal Singh, "Automobile Engineering - Vol.1", Standard Publishers Distributors New Delhi-110 00
- [5] R S Khurmi "Theory of Machiney", Sultan Chand publication.
- [6] National Program on Technical Enhanced Learning [NPTEL]

BIOGRAPHIES



Rushikesh Ambadas Mule is a student in SSM Adsul Polytechnic, Chas, A'nagar with specialization in Mechanical Engineering.



Avinash Sunil Kasar is a student in SSM Adsul Polytechnic, Chas, A'nagar with specialization in Mechanical Engineering.



Bilal Shaikh is a Lecturer in SSM Adsul Polytechnic, Chas, A'nagar with specialization in Mechanical Engineering.



Monali Thombare is a Lecturer in SSM Adsul Polytechnic, Chas, A'nagar with specialization in Mechanical Engineering.