

DESIGN AND FRABRICATION OF PNEUMATIC BORE WELL CHILD RESCUE SYSTEM

Suggala Vishal¹, T.Sree hari², Matta vidyasagar ³

¹ Department of mechanical engineering, sathyabama university. Chennai

² Department of mechanical engineering, sathyabama university. Chennai

³ Assistant professor, Department of mechanical engineering, sathyabama university

Abstract - Bores which yielded water and afterwards got depleted are left uncovered. A suitably strong cap of bright colour to cover the mouth of the bore will avoid such accidents. To aid in such rescue we have project a system. Methods to keep a child alive in a bore should take in to consideration the lack of oxygen, increased temperatures and humidity, which produces hyperthermia. These problems are addressed with fresh air delivery or without delivery of oxygen. A hand-powered equipment by using PNEUMATICS is being designed. This method brings down temperature and delivers fresh air with visualizing the child is made possible with infrared waterproof CCD cameras and a portable high resolution. The camera is suspended in a 200 feet cable. It will be a light weight mechanism .that will go down into the bore well pipe and hold the trapped body systematically. This assembly will be supported by a and rope roller drive, stand and all necessary accessories. A lot of other hassles will also be avoided by this alternative technique. This pneumatic type machine can rescue trapped body from bore well in minimum amount of time and safely ,life safe

Key Words: Hand-Powered Equipment ,Digital camera, Oxygen Concentrator, Design, Safety balloon, pulley ,Dc air compressor

These ad-hoc approaches involve heavy risks including the possibility of injuries to the victim's body during the rescue operations. Also, the body may trap further in the debris and the crisis deepens even more means death. In most cases, we trust on some makeshift arrangements. This does not assure us of any long term solution. In such methods some kind of hooks are employed to hold the sufferers clothes and body. This may cause wounds on the body of the subject. A single accident creates a big hue and cry spreading a sense of panic among the masses. It draws a lot of undue attention and criticism of the civil administration. Heavy expenses have also reportedly obtain in most cases. It is pertinent to mention that a proper technical solution for such emergency crisis is the needed. More so in times of technical advancements and continuous research, technician should take the responsibility to find an easy way out. It is an issue of national as well as social concern and an early step in the way of developing an instrument for the rescue of victims of such cases is desirable. After studying all the cases we found a serious issue to do, to made a such machine which can go through the trapped bore well without any support and hold the trapped body in least minimum time with providing facilities of oxygen cylinder, microphone, infra red LED. With this machine, there is no chance of damaging victim's body and other minor damages, and we called that machine as "Pneumatic Bore Well Child Rescue System ".

1.INTRODUCTION

Today's major problem faced by human is water scarcity, which leads to a large number of bore wells being sunk. These bore wells in turn have started to take many innocent lives. Bores which generate water and subsequently got depleted are left uncovered. Small children without noticing the hole dug for the bore well slip in and get trapped. There is no befitting technique to rescue victims of such accidents. When the make shift local arrangements does not work, Army is called in. In most cases reported so far, a parallel hole is dug up and then a horizontal path is made to reach to the victim's body. It is not only a time taking process, but also risky in various ways. Moreover it involves a lot of energy and expensive resources which are not easily available everywhere and in this process we need big space around the trapped bore that we can dig a parallel bore.

Table -1: Incidents Occurred in and around the Country

S. N	Name of the Child	Age	Place of the Incident	Recover red (Alive Or Not)	Source of Information (Newspaper)
1)	Deivar aj	6	Danduga	Recover ed alive and died in hospital	The Hindu- 9th June,2004
2)	Prince	8	Haryana	alive	The Hindu- 24th July,2007
3)	Dilraj Kaur	3	Chandiga rh	Not alive	The Hindu- June,4/2010

			(Dheera village)		
4)	D. Dinesh	2	Hyderabad	Not alive	Hindustan Times-19th Jan,2010
5)	Kariya	7	Davangere	Not alive	NDTV correspondent 18th Jan,2009
6)	Darawath Prasad	1.5	Warangal, AP	Not alive	NDTV correspondent 18th Jan,2010
7)	Sonu	2	Agra	Not alive	The Hindu-10th Oct,2010

1.2 Existing System

The main aim of this project is to make it possible for a child fall inside bore well to rescue without any injury. This goal is achieved by controlling a robot to take of the child inside the bore well which is operated by the person from outside. In existing system, a big hole is dug beside the bore well up to the depth where the child is stuck. A small delay in this resources accumulation may reduce the chances of saving the child alive. If the area beside the bore hole contains rocks below certain depth, in such cases the chance of saving child alive is very low. Lack of oxygen and light sources inside the bore well causes the major difficulty during the rescue operation. There is no such special equipment for rescuing the child inside the bore well. There is no proper technique to rescue victims of such accident. When the local arrangements do not work, army is called in. In most cases reported so far, a parallel hole is dug up and then horizontal path is made to reach to the subject's body. It is not only a time taking process, but also risky in various ways

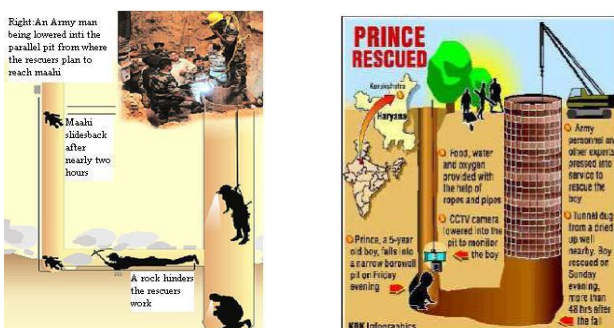

Fig -1: Existing System

Moreover it involves lot of energy and expensive resources which are not easily available everywhere and in this process we always need big space around trapped bore that we can dig. Whatever may be the case the success depends

on lots of factors like availability of time taken for transportation of machinery to the situation, human resources and mainly the response time of various government organizations. According to the NCRB report of 2011 there are 5 average deaths per day in the license bore wells. At present there is no proper result for this problem; in this paper the model of a robot arm which can be used for rescue operation is explained.

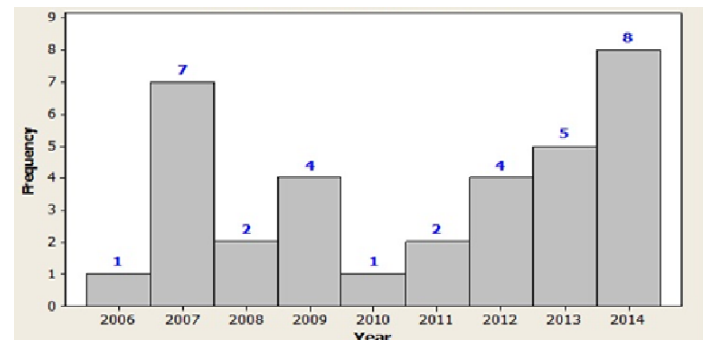

Chart -1: Bore well incidents between 2006-2014

1.3. Proposed System

This work is aimed towards the construction and design of a robotic system to work in borehole rescue operations and to detect faults inside the pipeline. The robot has arms at its front to pick and place the Available solutions (i) So far there is no proper solution available for giving relief in such accidents. Generally, a hole parallel to the bore-well is dug up then a horizontal way is created to reach to the subject's body. But it takes too much time to save the life of the sufferer. Moreover, it involves a lot of energy, and expensive resources which are not easily available everywhere. It also involves the possibilities of damaging the body of sufferer during the rescue operation loom large. (ii) In some cases makeshift arrangements are made to pull off the body of sufferer. In such methods some kind of hooks are used and sufferers' clothes or body organs get caught hold of. This may cause wounds on the affected body.

1.4. Possible alternative solutions

Pneumatics system should replace humans in the activities of performing repetitive and dangerous tasks which humans prefer not to do due to size limitations, extreme environments, etc. It will also perform various life-saving operations for the victims such as supply of oxygen and video camera to observe the actual situation closely and continuous interaction with the sufferer could also be possible

2. LITERATURE SURVEY

1. BORE WELL RESCUE ROBOT V. Venmathi, E. Poorniya, S. Sumathi The aim of this project is to give an innovative concept to handle the bore well rescue operations.

Nowadays child often falls down in the borehole which is left uncovered and get trapped. It is difficult and also risky to rescue the trapped children to aid in such rescue we proposed a system of designing robots to the rescue of a child in a borehole. The robot structure consists of power supply, switch pad, gear motors, Oxygen concentrator, camera and Microcontroller. The condition of trapped child is captured with CCTV camera and monitored on a TV. A safety balloon is introduced in order to provide extra safety. Once the lifting rod reaches a safe position under the child, an air compressor is operated to pump air to the bladder attached to the end of the lifting rod through an air tube that runs downwards inside the lifting rod. The bladder provides a safe seating to the child. When the child is secure, the lifting rod is contracted to its maximum position.

2. AN AUTOMATIC ROBOT TO RESCUE THE CHILD FROM BORE WELL SYSTEM S. Gopinath, T. Devika, M.Jagadeeshraja, M. Rajendiran This paper is based on the recovery of children who fallen into borewell. Due to drought and depletion of underground water more bore wells are drilled on the surface of the earth. When the ground water gets dried or polluted nearby industries, the motor along with casing pipe are removed and the outer, surface of the bore is not insulated properly. As a result of this, the children who were playing near the bore. The arm movement of the robot is controlled by stepper motor. Once child is perfectly picked by robot, BLDC motor is used to lift up the child from borewell. The ZigBee plays a vital role of data transferring between the victim in borewell and the recovery team in earth surface. The simulation results are obtained by using Solid works. The hardware output is implemented and the results are shown

3. BOREWELL RESCUE SYSTEM Venmathi.V1, Monisha.P, Muthuselvi.P, Poorani.K, Ramya.A This paper is generally based on the child rescue in the bore well. Nowadays child falls into an abandoned bore well, which is left uncovered and get trapped. Normal operation to rescue the child is to pit a dig nearer to the bore well.. The mechanical system moves inside the uncontrolled bore well. Accordance with the user command given to the Arduino, the mechanical setup is controlled. The hardware is attached to the PC, to stimulate the DC motor. This kind of system can release trapped baby from the bore well securely within lesser time.

3. PNEUMATIC BORE WELL RESCUE

In this system mainly pneumatics as main role with help of pneumatics child is rescued from incident

Our constructed model totally worked based upon the pneumatics. The compressed air will push the pneumatic cylinders forward when rthe total setup get into the bore well in order to pick the the child. Initially the setup will get into with the help of DC motor. When DC motor rotated with help of battery then it will release the rope into the well at the end of rope we’ve connect the pneumatic cylinders. One of the pneumatic cylinder is used to pick the child and another pneumatic cylinder is used to extend the total length of the setup based on requirement. And one webcam is placed to find the exact location of child.

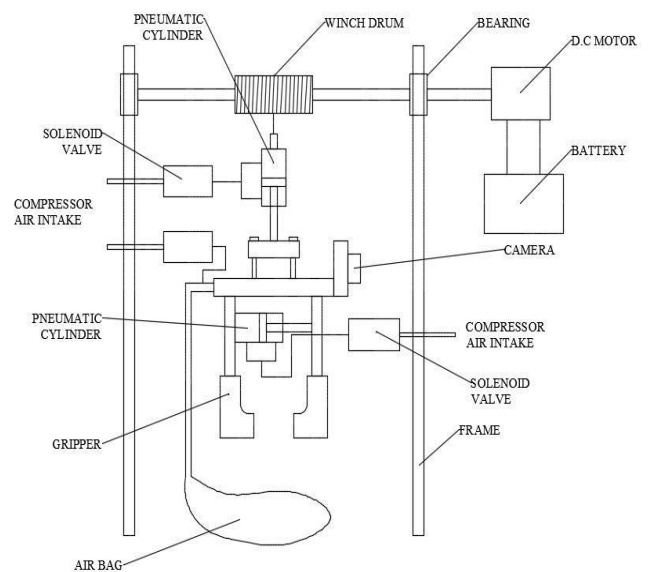

Fig -2: 2D lay out

The working mechanism of this projected system is a combination of pick and place mechanism, data acquit ion system and the safety mechanisms for dealing with a human life. The overall working of the system deals with two cases based on the position of the victim i.e. whether the victim is trapped in the midway inside the well or at the bottom end of the well.

3.1 Design By Using Catia Software

CATIA is the only solution capable of addressing the complete product development process, from product concept specification through product-in-service, in a fully integrated and associative manner. Based on an open, scalable architecture, it facilitates true collaborative engineering across the multidisciplinary extended enterprise, including style and form design, mechanical design and equipment and systems engineering, managing digital mock-ups, machining, analysis, and simulation. By enabling enterprises to reuse product design knowledge and

accelerate development cycles, CATIA helps companies to speed-up their responses to market needs.

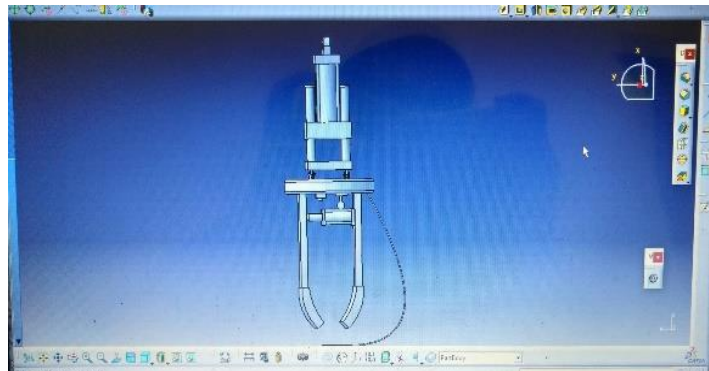

Fig -3: Front View

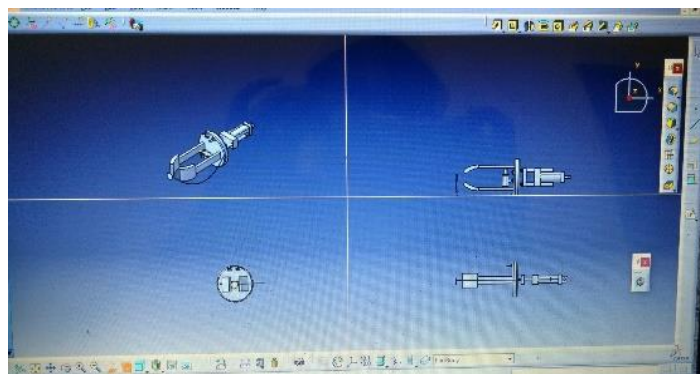

Fig -4: All Sectional Views

Based on the above design, the whole system consists of the setup which is to be sent inside the borewell. It includes the pneumatic assembly for fixing the system inside the well, the parabolic shape gripper, temperature sensor to measure the temperature inside the borewell, measure amount of oxygen inside the well for the victim, the wireless video camera and its transmitter to continuously monitor the condition of the victim

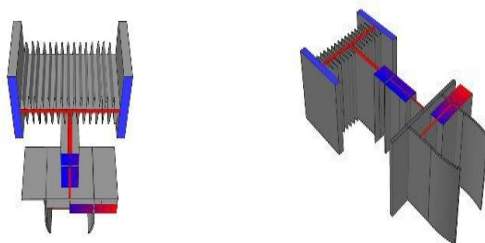

Fig -5: Model Diagram

Mechanism of this pneumatic projected system is a combination of pick and place mechanism, data acquisition system and the safety mechanisms for dealing with a human life. The overall working of the system deals with two cases

based on the position of the victim i.e. whether the victim is trapped in the midway inside the well or at the bottom end of the well.

4 COMPONENTS USED

Table -2: list of components

S.N	components
1	Pneumatic Cylinder
2	Solenoid Valve
3	Hoses and Connections
4	Rope
5	Shaft
6	Bearing with Clamp
7	DC Motor
8	Battery
9	Metal Strip
10	Camera
11	Air balloon
12	Frame

4.1 Double Acting Pneumatic Cylinder

- Stroke length : Cylinder stoker length 160 mm = 0.16 m
- Quantity : 1
- Seals : Nitride (Buna-N) Elastomer
- End cones : Cast iron
- Piston : EN - 8
- Media : Air
- Temperature : 0-80 ° C
- Pressure Range : 8 N/m

4.2 Design of Piston rod:



Fig-6:Piston Rod

Load due to air Pressure.

Diameter of the Piston (d) = 40 mm

Pressure acting (p) = 6 kgf/cm²
 = 6 × 0.981
 = 5.886 bar = 0.5886N/mm²

Material used for rod = C 45
(data book page no 1.12)

Yield stress (σ_y) = 36 kgf/mm²
= 36×98.1
= 3531.6 bar
= 353.16N/mm²

factor of safety = 2 (data book page.no 8.19)

force acting on the rod (F) = Pressure x Area

= p x ($\Pi d^2 / 4$)

= 0.5886 x { ($\Pi \times 40^2$) / 4 }

F = 739.6N

Design Stress(σ_d) = σ_y / FOS

= 353.16 / 2

= 176.5N/mm²

$\therefore d = \sqrt{4F/\pi [\sigma_d]}$

= $\sqrt{(4 \times 739.6) / \pi [176.5]}$

\therefore Minimum diameter of rod required for the load = 2.3 mm

We assume diameter of the rod = 15 mm

4.3 Design Of Ball Bearing



Bearing No. 6202 (Data book page.no 4.13)

Outer Diameter of Bearing (D) = 35 mm

Thickness of Bearing (B) = 12 mm

Inner Diameter of the Bearing (d) = 15 mm

r_1 = Corner radii on shaft and housing

$r_1 = 1$ (From design data book)

Maximum Speed = 14,000 rpm
(From design data book)

Mean Diameter (dm) = (D + d) / 2 =
(35 + 15) / 2 dm = 25 mm

4.4 Hand lever solenoid valve



- Valve type: 5/2 valve
- Working medium: compressed air
- Material: Aluminum and plastic

4.5 Connector

- Max working pressure: 10×10^5 N/m²
- Temperature : 0-100 ° C
- Fluid media : Air
- Material : Brass

HOSE SPECIFICATION

- Max pressure : 10×10^5 N/m²
- Outer diameter : 6 mm = 6×10^{-3} m
- Inner diameter : 3.5 mm = 3.5×10^{-3} m

4.6 Rope:



Specifications:

Diameter: 1-10 mm

Length:50-100m

•UIAA (Union Internationale des Associations d'Alpinisme)

• According to UIAA standards, required type of rope is selected.

PROPERTIES OF THE ROPE.

S.N	PROPEY	RANGE/NAME
1	Diameter (mm)	15-25
2	Weight (g/m)	250
3	Break load (Kg)	11200
4	UIAA Fall Rating	15-25

4.7 D.C Motor:



The electrical motor is an instrument, which converts electrical energy into mechanical energy. According to faraday’s law of Electromagnetic induction, when a current carrying conductor is placed in a magnetic field, it experiences a mechanical force whose direction is given by Fleming’s left hand rule

- DC Motor capacity : 12V
- Un loading : 130rpm
- Loading : 90rpm

4.8 Camera:



Specifications

C170 webcam
 Video Capture: up to 1024x768 pixels
 Photos: Up to 5 mega pixels

5 MECHANISM OF WORKING

The working mechanism of this projected system is a combination of pick and place mechanism, data acquit ion system and the safety mechanisms for dealing with a human life. The overall working of the system deals with two cases

based on the position of the victim i.e. whether the victim is trapped in the midway inside the well or at the bottom end of the well. Below is the stepwise description of the detailed working of the system:



Step 1: Setup the system outside the borewell with the help of a metal stand.

Step 2: Connect the rope to the pulleys and slowly lower the system inside the borewell.

Step 3: As the machine is sent into the bore-well hole, with the help of small pneumatics it adjust the space to carry victim which is attached along the rope

Step 4: As the system approaches the victim his position can be monitored on the PC with the help of wireless camera attached to the lower plate of the setup.

Step 5: Based on the position of the victim rotate the setup such that the two parabolic plates are right above the arms of the victim

Next step is based on the two cases stated below:

CASE I. When the victim is struck mid way in the bore well
 Step 6: Adjust the orientation of the plates with respect to the victim’s position and hold the victim by his arms to prevent further sliding.

OR

CASE II. When the victim is struck at the bottom end of the bore well

Step 6: Adjust the orientation of the plates with respect to the victim’s position and hold the victim by his arms to and pull him up slightly such that some space is created at the bottom.
 (To prevent excessive pressure on victim’s arms the internal layer of the plates is lined with some soft material).

Step 7: Now lower the cage assembly such that it reaches at least 10 centimetres below the victim.

Step 8: with the help of compressor blow the air slowly inside the safety balloon attached to a strip of the cage.

Step 9: when the balloon is completely blown pull the cage assembly slightly upwards such that the victim get the support of the balloon from the base.

Step 10: After ensuring the safety of the victim pull the whole setup slowly outwards.

6.CONCLUSION

Human life is precious. Bore well child saver is a significant attempt to save life of the victim of bore well accidents. Besides this the unique capability of climbing through vertical and inclined pipes make wide scope of application for this machine in manufacturing industries and other relevant fields. Following are some important points observed during the design and fabrication of machine. In the current design of bore well child saver machine is has been made to suit every possible situation may occur in rescuing operation. The structure is made strong enough to sustain all possible loads, though it is made flexible at the same time to adjust wide range of bore diameter and any change in the diameter of bore. In this rescuing operation time is a vital factor which alone can deter mine the success or failure of the whole operation. Thus it has been designed keeping the entire obstacle in mind that may arise during the operation. The controlling of the vehicle and the rescue robot is highly sensitive that makes it possible to reach to high depth as soon as possible and handle the human child without hurting. The outlook of end effector of the rescue robot is design in that way that it should not threaten the child or it should appear friendly to the child.

REFERENCES

[1] Gopinath.S , Devika.T , Manivannan.L , Dr.N.Suthanthira Vanitha4 "Rescue Child Chfrom Bore well using Embedded System|| Volume: 02 Issue: 03 | June-2015 e- ISSN: 2395 - 0056 p-ISSN: 2395- 0072

[2]Nithin.G, Gowtham.G, Venkatachalam.G and Narayanan.S –Design And SimSimulation Of Bore Well Rescue Robot – Advanced|| Vol. 9, No. 5, May 2014 issn 1811819-6608

[3] Dr. Sakhale.C.N , Mate.D.M , Subhasis Saha, –An Approach to Design of Child SavSaver Machine for Child Trapped in Borehole|| Volume 1,Issue 2,October-DecDecember,2013,pp.26-38,© IASTER,2013

[4] Sanket Arun Talekar, Suraj Bhimrao Katkar, Pooja Kumari –Rescue System for Bor Borewell Accidents|| ISSN (Online): 2347 - 2812, Volume-3, Issue -2, 2015

[5] Saran.K, Vignesh.S, Marlon Jones Louis. –BORE-WELL RESCUE ROBOT|| ISSN (ON(O)NLINE): 2321-3051

BIOGRAPHY

1. SUGGALA VISHAL

Department of mechanical engineering, sathyabama university. Chennai



2. SERR HARI

Department of mechanical engineering, sathyabama university. Chennai



3. Vidyasagar Matta ,

Assistant professor, Department of mechanical engineering, sathyabama university.