

Fabrication of PADDY SAPLINGS TRANSPLANTER

B. Yaswanth¹, B. Mark Kenneth¹, B. Koti Kiran¹, Ch N.V.S Vara Prasad¹,
Dr M.S.R Niranjan Kumar²

¹Research Scholars

¹Department of Mechanical Engineering, P.V.S.I.T. Kanuru (A.P), India-520007

² Professor

²Department of Mechanical Engineering, P.V.S.I.T. Kanuru (A.P), India-520007.

Abstract- A Paddy saplings transplanter is a specialized machine used for planting paddy saplings[1] into the fields with less effort and with high efficiency. The model is designed in the PRO-E software so that we can get an idea about the dimensions, mechanisms and cost expenses. This model mainly consists of three main shafts which play a key role in planting the saplings. These shafts are attached with chain mechanism so that it can facilitate rotary motion transmission from shaft-1 to shaft-2. Later this rotary motion is converted into reciprocating motion with the help of a disc with eccentric hole. This disc is attached to the floaters with a link so that the floaters can plant the saplings. However, rice transplanters are considerably expensive for almost all small-hold farmers. The present work is mainly intended to manufacture a cost effective machine so that it will be on reach to the small scale farmers

Key Words: Paddy Saplings Transplanter, Disc with eccentric hole, Rotary motion, Reciprocatory motion, Floaters, Cost effective.

1. Introduction

India is mainly an agricultural country. Agriculture is the most important occupation for most of the Indian families. In India, agriculture contributes about sixteen percent (16%) of total GDP and ten percent (10%) of total exports[2]. Over 60 % of India's land area is arable making it the second largest country in terms of total arable land. Agricultural products of significant economic value include rice, wheat, potato, tomato, onion, mangoes, sugarcane, beans, cotton, etc. It takes 5,000 liters of water to produce 1 kg of irrigated rice. To plow 1 hectare of land in the traditional way, a farmer and his water buffalo must walk 80 km[3].

Agriculture is the backbone of Indian economy. Though, with the growth of other sectors, the overall share of agriculture on GDP of the country has decreased. Still, Agriculture continues to play a dominant part in the overall economic scenario of India[4]

2. Need For Paddy Planter

- Transplanting is tedious and time-consuming.
- Planting laborers can suffer from back problems.
- Difficult to get enough labor at peak periods to plant on time.
- Difficult to maintain optimum spacing and uniform plant density, especially with random transplanting and contract labor.
- Low plant density with contract transplanting on area basis lowers yields.
- Possible Risk that in rain fed areas seedlings (especially of modern varieties) may get too old before rain falls and the field is ready to be planted.[5]

3. From an Idea to the Real world application:

- Theme – Agricultural related
- Field work
- Idea
- Project Drawings
- Cost estimation
- Purchasing of Material
- Manufacturing
- Assembling
- Problems and solutions

4. Components Of Paddy Transplanter

In the entire mechanism, the mechanical Paddy transplanter has totally three shafts:

- Shaft-1 with Toothed iron wheel
- Shaft-2 with disc having eccentric hole
- Shaft-3 with floaters
- Frame

Shaft-1 with Toothed Iron Wheel

Diameter: 1inch (25.4mm).

Length : 200 mm.

Type : Simply supported.

- A disc of 282 mm diameter and of thickness 6mm is made from a MS plate through gas cutting.

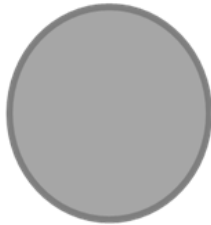

Fig: Disc without slots.

- The slots are made with a width of 8mm and 60mm into the wheel so that the flat plates which are cut through gas cutting can be placed in their respective slots.



Fig: Disc with slots.

- Additionally we took a flat plate and made 12 pieces of them which are 100mm in length, 8mm in thickness and 48mm in width.

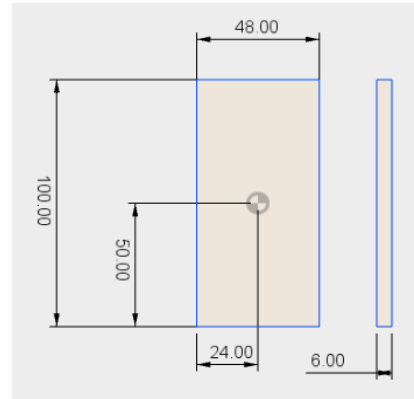

Fig: Slots with Dimensions

- These plates are attached into the slots made on the base wheel.



Fig: Slotted disc in PRO-E Sketch.

- The feed from the wheel should be transferred to the mechanism, in order to do that a big sprocket wheel which is generally used in the bicycle is attached to the same shaft on which toothed wheel is placed. The big sprocket wheel is provided with a bush fit so that it can be moved later for the purpose of alignment with small sprocket of chain mechanism.

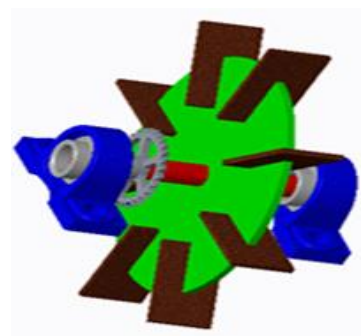
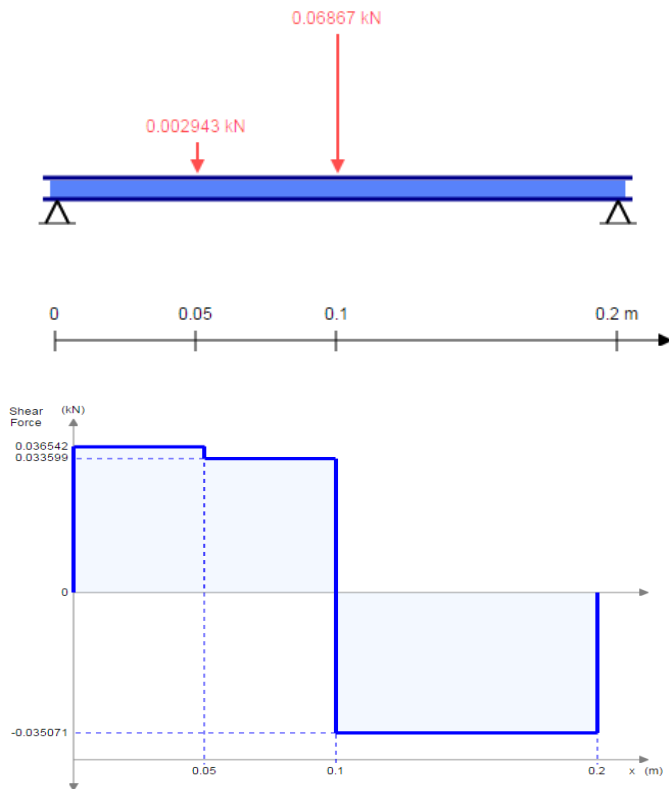

Fig: The PRO-E sketch of slotted disc with the Bearings

SHAFT-2 (Single Sided Over Hanged Beam):

- The feed from the big sprocket wheel on the shaft-1 is to be transferred and for this a chain mechanism is arranged.
- Now this should be transferred to the small sprocket wheel. In order to do so another shaft of length 130mm of 1 inch diameter is taken
- Additionally the shaft 2 is fixed with a disc which plays a key role in the planting mechanism. The disc used on this shaft is of 6mm thick and 60 mm dia.
- To this disc a hole eccentrically at a radial distance of 40mm from the centre is made. To this eccentric hole a link is attached with the help of a screw to transmit to and fro motion to the plant catching mechanism which is placed on the shaft-3.



Shear force diagram

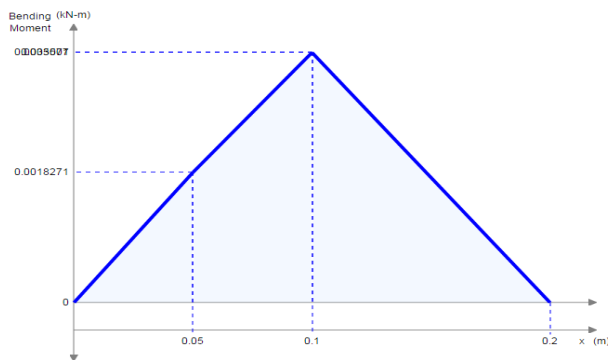

Bending moment diagram

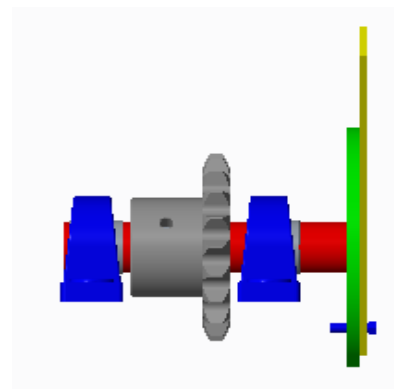
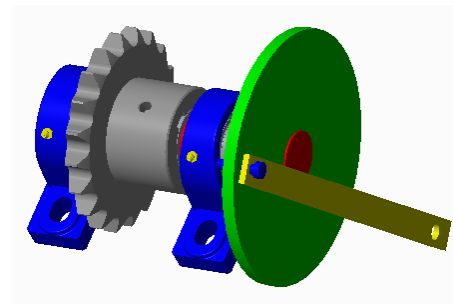

Fig: PRO-E Sketch of Double Side over Hanged Beam

SHAFT 3 (Double Sided Over Hanged Beam):

- This is a stepped shaft provided with the floaters at the end.
- A plain shaft of 20mm diameter and of length 350mm is taken.
- With help of lathe machine a step on either side of the shaft is provided decreasing about 5mm each side.
- The floaters are fixed on the stepped part.

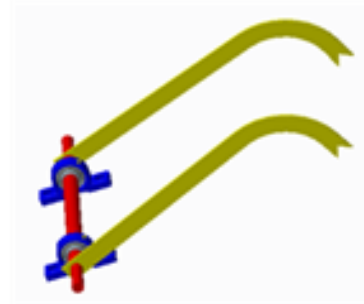
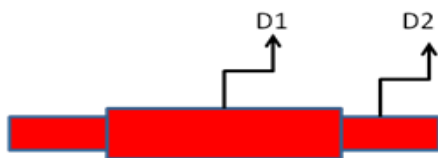

Fig: Shaft and the Floaters.



D1 – 20mm
D2 – 15mm

Frame

- All the shafts are designed but are to be fixed on a platform for a perfect functioning of the machine.
- A frame according to the better functioning of the shafts and parts is made by using a 1 inch square pipe of 6 feet long.

Floater Design

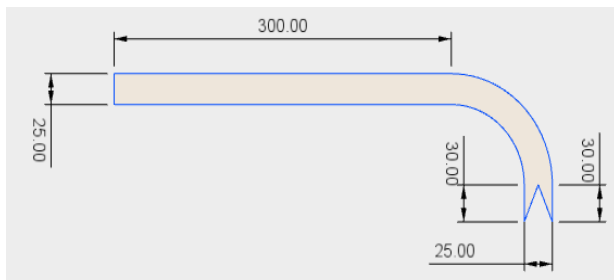

- After cutting the floaters from an MS sheet the floaters are provided with bush fit so that if any error in the future is to come can be corrected.
- The parameters that are considered while designing the floaters are:
 - Place of catching
 - Number of plant per catching
 - Distance of travel
 - Releasing Point
 - Tension on plants
 - Angle of Planting

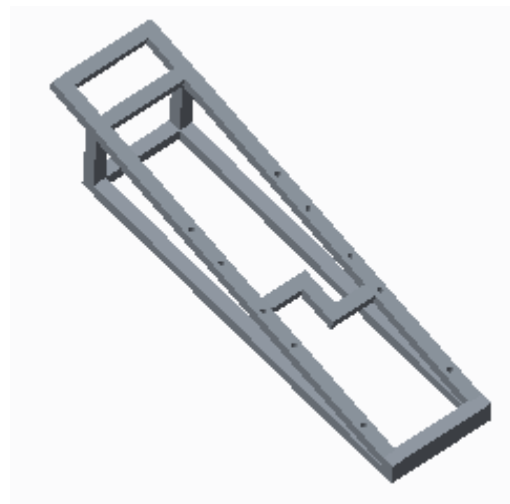
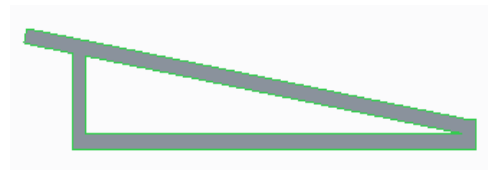

Fig: PRO-E sketch of the Frame

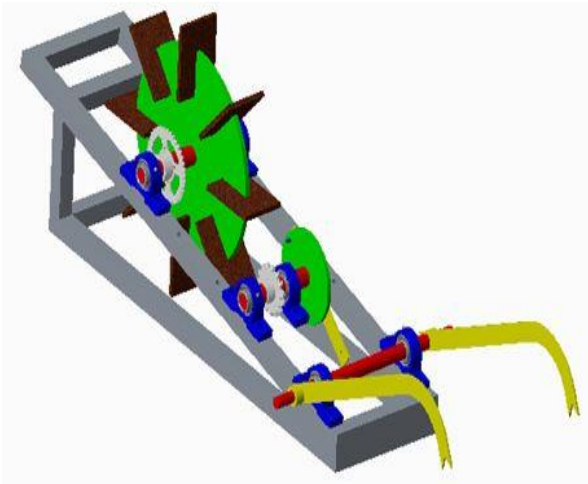

Fig: Frame with the components in PRO-E sketch.

Tray

- Tray is the main component which carries the paddy saplins that are to be planted.
- Basic factors (width, length, angle, speed of movement) are considered in designing the tray mechanism.
- As two plant rows were planted at once, the tray width is twice as plant space.
- The volume taken by finger depends on the space of the finger jaw.

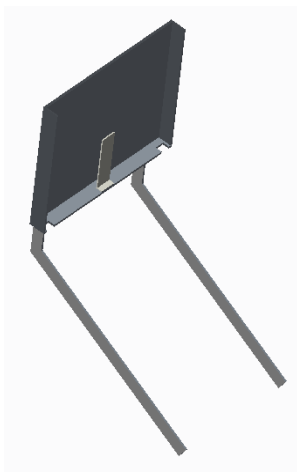
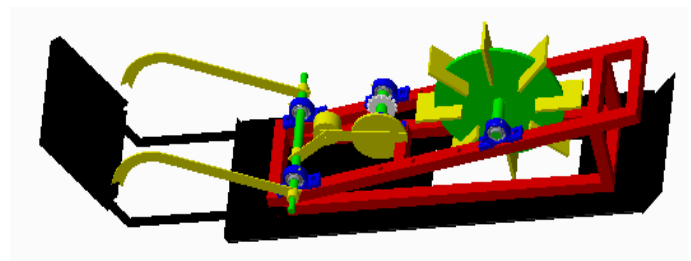
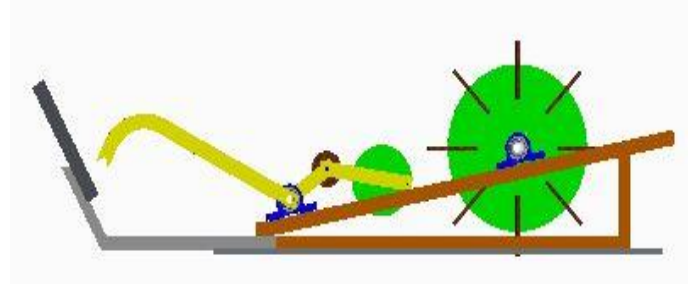

Fig: Tray

Virtual Diagram of Paddy Saplins Transplanter



FUTURE SCOPE

Enhancement with motor

- The machinery we made takes the feed from the base wheel which is driven by or pulled by a human manually.
- The work done by a human to pull this machine can be further more decreased by placing a motor to the base wheel so that the feed is taken automatically from the motor to the base wheel.

Rice Harvester

- The machinery's purpose is to plant the paddy saplins. After planting the plants grow and the plants need to be cut down to take the crop.
- For this there are some machines called rice harvesters whose purpose is to cut the grown crop.
- This same mechanism can be attached at the bottom with some improvements being done.

- A small motor can be fixed at the bottom which can help in cutting the crop and two rods should be placed so that the crop which is cut down can be diverted from the way because if the crop is not diverted from the way as the machine goes through it there is chance of getting some crop to go under the machinery which can contaminate the crop.

Enhancement with More Plant Catching Mechanism

- The machine we used is of just two floaters provided on the third shaft.
- The number of the floaters can be increased further more to develop the number of plants planted per a revolution.
- As of now we were just able to plant two plants per cycle. This can be improved by increasing the length of the third shaft and increasing the number of floaters.

Enhancement by incorporating Line follower mechanism

- Normally the machine that we have designed will be operated manually but if we incorporate the line follower mechanism to this machinery automatic feed can be obtained.
- In this mechanism we will use sensors which absorb white light. If we make a path by drawing white lines in the field the sensors that are attached to the machinery will sense the white light and the controller which is attached to the machinery will take the input from the sensors and it will guide the machinery to follow the white line region

Real Time Monitoring using a camera:

- While we are planting the saplings using this machine due to some unavoidable errors sometimes saplings will not be planted properly.

- In order to monitor this we can fix a camera on the top the tray on its back so that we can clearly trace out the region where the plant sapling has not been planted properly.

Advantages

- Efficient use of resources by saving on labour, cost saving, water.
- Timely transplanting of seedlings.
- Ensures uniform spacing and optimum plant density with 2-3 saplings).
- Higher productivity compared to traditional methods.
- Less transplanting shock, early vigor of seedling, better tillering and uniform.
- Maturity of crop that facilitates timely harvest and reduces harvest losses.
- Less incidence of disease in seedlings due to less root injury.
- Improving soil health through eliminating puddling.
- Generates employment and alternate sources of income for rural youth through custom services on nursery raising and mechanical transplanting

Result And Discussion

- Prototype mechanism was evaluated in the field, and it worked. There were some points to be redesigned.
- Tray mechanism worked but the design should be altered or improved. The problem we have faced while planting the saplings is that stacking of paddy saplings is seen to be occurred.
- To avoid such problem we can incorporate tray moving mechanism made of iron sprocket wheel to facilitate movement of paddy saplings for any individual cycle so as to avoid the stacking of paddy saplings.
- The sprocket and chain used for the machine was foot cycle chains and sprockets. When machine is operated the sprockets get damaged by bending the teeth.

- So it is better to have motorcycle chains and sprockets to power transmission. But that will result an increase in weight. Therefore, instead of chain and sprocket speed reducing mechanism, a gear system should be used.
- In this machine ground wheel supplies the power to operate transplanting arm and tray mechanism. Pulling the machine will rotate the ground wheel.
- Increasing the size and number of lugs (fins) around ground wheels will increase contact area of the ground wheel with the field and make it easy to operate.
- The machine has to pull to operate. Ergonomically it is better to push weight rather than to pull. So it is better to turn the handle and the power supplying mechanism to push the machine instead of pulling it.
- Use of aluminum and alloy for construction will help to reduce the weight of the machine. The machine used to plant 2 rows simultaneously.

Conclusion

- Rice paddy transplanter is highly recommended for the local farmers though beforehand the farmers need to be educated regarding its proper use since mechanized transplanter requires mat type nursery.
- Since the farm land is of the average size in the area thus a mechanized paddy transplanter would highly aid in the rice transplantation.
- It would also decrease the high dependence of farmers upon laborers for transplantation.
- The transplanter machine can be easily coupled to a weed remover mechanism which could further help farmers in the weeding process of paddy plantation.

References:

- [1] https://en.wikipedia.org/wiki/Rice_transplanter
- [2] Jagjot Singh Gill, Sohan Singh Walia, Roopinder Singh Gill, Direct seeded rice: An alternative rice establishment technique in north-west India, International Journal of Advanced Research, 2(3), 2014, 375-386.
- [3] S. V. Ngachan, A. K. Mohanty, A. Pattanayak, Status Paper on Rice in North East India.
- [4] R.P. Murumkar, U.R. Dongarwar, D.S. Phad, B.Y. Borkar and P.S. Pisalkar, Performance testing of a four row selfpropelled paddy transplanter, International Journal of Science, Environment and Technology, 3(6), 2014, 2015-2019.
- [5] M. Muthamil Selvan, S.J.K.Annamalai, N. Thavaprakash, D. Ananathakrishnan, Design and development of three-row improved pull-type rice transplanter for small farmers, The Indian Journal of Agricultural Science, 84(11), 2014.