

Design and Fabrication of Pneumatic Sheet Metal Cutting and Pneumatic Sheet Metal Bending Machine

Dinesh Lamse¹, Akash Navghare², Rahul Chavhan³, Ajay Mahawadiwar⁴

¹Student, Department Mechanical Engineering,

²Student, Department Mechanical Engineering,

³Student, Department Mechanical Engineering,

⁴Professor, Department Mechanical Engineering, AGPCE, Nagpur, Maharashtra, India

Abstract - Pneumatics systems are extensively used in a wide range of industries and factories and manufacturing sector entities. Pneumatics system are noted for their simplicity, reliability, and ease of operation. Also they are suitable for fast and rapid application of force.

The purpose of this project is to therefore design a simple, easily operated pneumatic sheet metal cutting and bending machine that is sturdy and strong. A pressure of 8-10 bar is enough for operating the unit. The pressurized air passing through the tubes to the cylinder, forces the piston out whose power through the linkage is transmitted to the punch.

The work piece thus got is for required dimensions and the piece can be collected through the land clearance provided in the die. The die used in this is fixed such that the die of required shape can be used according to the requirement. This enables us to use different type punch dies resulting in a wide range of products. Different types of punch as requirement can be thus got. According to the work material the operating pressure can be varied.

Key Words: Pneumatic System, Direction Control Valve, Compressor, Sheet Cutter, Bending Punch & Die.

1. INTRODUCTION

The shearing machine and bending machine is most important in sheet metal industry. This machine should be used for straight cutting machine with wide application. But in some industry hand sheet cutter and hand bender are used. For that machine to operate the human effort are required. The machine should be simple to operate and easy to maintain, hence we tried out to develop the Pneumatic Shearing and Bending Machine.

In shearing operation as the punch descends upon the metal, the pressure exerted by the punch first cause the plastic deformation of the metal. Since the clearance between the punch and the die is very small, the plastic deformation takes

place in a localized area and the metal adjacent to the cutting edges.

In bending operation the bend has been made with the help of punch which exerts large force on the work clamped on the die. The bending machine is designed in such a way that, it works automatically. The machine is designed by observing the factors to improve the efficiency and to reduce the cycle time by producing quality output. Automation of machine is achieved with the help of pneumatic system. This involves the design of an efficient system which reduces the human effort and help to increase production output. It also includes pneumatic system, pneumatic component and shearing die and bending die.

1.1 LITERATURE REVIEW

Sheet metal bending is one of the most widely applied sheet metal forming operations. The understanding of the bending mechanics is aimed at obtaining two kinds of information important for industrial applications. The first one is the springback prediction for die design and shape control. The second is an estimation of the bend force for selection of press capacity, strength analysis and design of dies.

Here an attempt is made to review the status of literature in pneumatic based on various criteria. The work done by various authors are explained below.

Vallance and Matlock (1992) studied the friction behavior of zinc-based coated sheet steels and laboratory scale friction analysis techniques that involve sheet sliding over cylindrical dies.

Mai Huang and Gardeen (1994) presented a literature review of the springback of doubly curved developable sheet metal surfaces and provided a bibliography on the springback in sheet metal forming. Reviewing the literature, it is found that researchers have been studying the phenomenon of springback for nearly six decades. There

have been diverse efforts to evaluate and/or decrease springback in the sheet metal forming industry for a long time.

Perdijn and Hoogenboom (1995) derived a simple explicit bending couple curvature relation for small and larger curvatures and they verified the model with experimental results.

Sanchez (1999) focused on a systematic analysis of testing equipment as a measurement system of the friction phenomena on sheet metal under plane strain. It provides experimental references in order to optimize the usage of lubricants and sheet metal.

Samuel (2000) analyzed the springback in axisymmetric U-bending processes with a finite element program and discussed the effect of tool geometry and blank holder force on the final shape after springback.

Aleksy et al (2001) conducted experiments on springback for dual phase steel and conventional high strength steel for a hat channel section with varying cross sections. They described the methodology of experiments and discussed springback related results.

Carlos Gomes et al (2005) investigated the variation of springback in high strength steels based on experimental and numerical analysis.

Dongye Fei and Peter Hodgson (2006) investigated the springback behaviour of cold rolled transformation induced plasticity (TRIP) steels in air v-bending process.

Se Young kim et al (2007) examined the effect of tool design and process parameters on the springback of GLARE and the parameters studied include punch radius, punch speed, forming load and forming temperature.

In shearing or cutting operation as or blade descends upon the metal, the pressure exerted by the blade first cause the plastic deformation of the metal. Since the clearance between the two blades is very small, the plastic deformation takes place in a localized area and the metal adjacent to the cutting edges of the blade edges becomes highly stressed, which causes the fracture to start on both sides of the sheet as the deformation progresses and the sheet is sheared.

Types of shearing Machine:

- 1) Pneumatically operated
- 2) Hydraulically operated
- 3) Rack and pinion operated
- 4) Spring operated

Brief description of all the types is as follows :

1) Pneumatically operated: - Here the advancement of the header is carried out in the upward and the downward direction using the pneumatic double acting piston and cylinder unit arrangement along with the foot operated direction control valve. In this type of machine high pressure air is used as the working fluid for the transfer of power and the motion.

2) Hydraulically operated: - Here the lowering and raising of the header is carried over using the hydraulic piston and cylinder arrangement. To actuate the piston and cylinder, the oil is allowed to enter the cylinder from front or the back side of the piston. But the oil is comparatively costlier and its leakage may cause so many problems.

3) Rack and pinion operated: - Here the lowering and the raising of the header are carried out manually using the rack and pinion arrangement. In this case the required pressure is applied manually using direct hand pressure on the rack using pinion and lever arrangement. Since the machine is robust and requires large pressure, hence it is not suitable.

4) Spring operated: - The working of spring operated machine is similar to the rack and pinion operated machine but differs from it in construction. Here the lowering and the raising of the heating handle are carried out manually and it requires too much pressure for its operation and also there is possibility of having damage to the work piece if not handled carefully.

2. COMPONENT USED

2.1 Pneumatic Cylinder

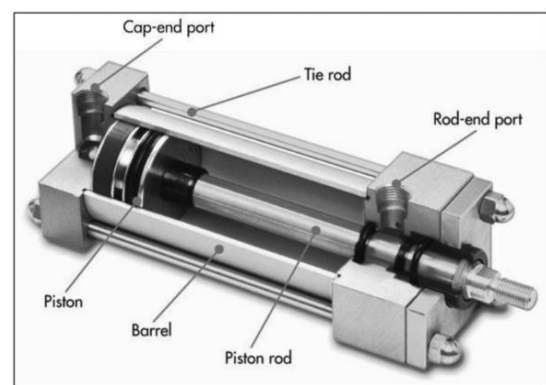

Pneumatic cylinders (sometimes known as air cylinders) are mechanical devices which use the power of compressed gas to produce a force in a reciprocating linear motion. In pneumatic cylinder a compressed air is used as working fluid and convert it into kinetic energy as the air expands in an attempt to reach atmospheric pressure. This air expansion forces a piston to move in the desired direction.

The piston is a disc or cylinder, and the piston rod transfers the force it develops to the object to be moved. Engineers prefer to use pneumatics because they are quieter, cleaner, and do not require large amounts or space for fluid storage. Because the operating fluid is a gas, leakage from a pneumatic cylinder will not drip out and contaminate the surroundings, making pneumatics more desirable where cleanliness is a requirement.

2.2 Direction Contrl Valve



The directional valve is one of the important parts of a pneumatic system. Commonly known as DCV, this valve is used to control the direction of air flow in the pneumatic system. The directional valve does this by changing the position of its internal movable parts. This valve was selected for speedy operation and to reduce the manual effort and also for the modification of the machine into automatic machine by means of using a solenoid valve.

A solenoid is an electrical device that converts electrical energy into straight line motion and force. These are also used to operate a mechanical operation which in turn operates the valve mechanism. Solenoids may be push type or pull type. The push type solenoid is one in which the plunger is pushed when the solenoid is energized electrically. The pull type solenoid is one in which the plunger is pulled when the solenoid is energized. The name of the parts of the solenoid should be learned so that they can be recognized when called upon to make repairs, to do service work or to install them.

2.3 POLYURETHANE TUBE



A pipe is a tubular section or hollow cylinder, usually but not necessarily of circular cross-section, used mainly to convey substances which can flow liquids and gases (fluids), slurries, powders, masses of small solids. It can also be used for structural applications; hollow pipe is far stiffer per unit weight than solid members.

In common usage the words pipe and tube are usually interchangeable, but in industry and engineering, the terms are uniquely defined. Depending on the applicable standard to which it is manufactured, pipe is generally specified by a nominal diameter with a constant outside diameter (OD) and a schedule that defines the thickness. Tube is most often specified by the OD and wall thickness, but may be specified by any two of OD, inside diameter (ID), and wall thickness.

2.4 PNEUMATIC COMPRESSOR



An air compressor is a device that converts power (using an electric motor, diesel or gasoline engine, etc.) into potential energy stored in pressurized air (i.e., compressed air). By one of several methods, an air compressor forces more and more air into a storage tank, increasing the pressure. When tank pressure reaches its upper limit the air compressor shuts off. The compressed air, then, is held in the tank until called into use.

The energy contained in the compressed air can be used for a variety of applications, utilizing the kinetic energy of the air as it is released and the tank depressurizes. When tank pressure reaches its lower limit, the air compressor turns on again and re-pressurizes the tank.

2.5 SHEET METAL CUTTER



Sheet metal cutter is used to cut the metal sheet of 5 mm. We have compressor of capacity 8 to 14 kg/cm² which is sufficient to cut the 5 mm thickness plate.

4.	Cutting blade	Alloy steel
5.	Fixing blade	Alloy steel
6.	Both side control valve	Steel

2.6 BENDING PUNCH AND DIE

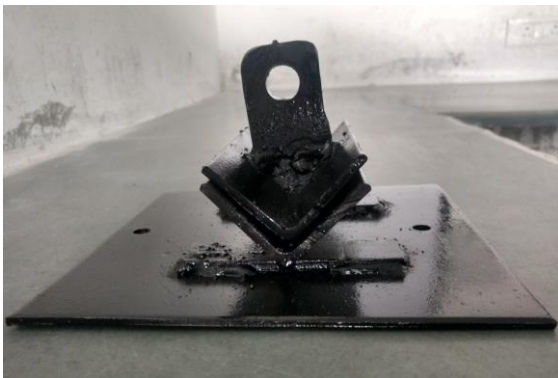

To perform bending operation, the bending punch and die has to replace with cutter and then after we can perform bending operation. Bending angle is 90° and as per the requirement in future we can change the angle of bending.

Table -1: COMPONENT'S MATERIAL

SR.NO.	COMPONENT NAMES	MATERIAL
1.	Frame	Mild steel
2.	Cylinder	Alloy steel
3.	Piston rod	Carbon steel

ADVANTAGES

- The pneumatic is more efficient in the technical field.
- Quick response is achieved.
- Easy maintenance and repair.
- Low investing cost.
- Continuous operation is possible without stopping.
- Compact size and less floor space is used.
- All movements are pneumatically operated.
- Optional solution of operation is Electrical control panel.
- Ragged construction to suit in highly acidic atmosphere & high temperature.
- All pneumatic actuators are S.S. to suit corrosive atmosphere.
- Air is available everywhere
- Can be stored easily
- Clean and non – pollutant
- Transportable over long distances
- High speed operation
- Relatively low cost to produce
- Largely insensitive to temperature
- Technology can be easily learned

APPLICATIONS

- FOR Paper cutting
- For sheet cutting
- For stamping operating

- For bending operation

Fig-1: ACTUAL MODEL OF PNEUMATIC SHEET METAL CUTTING AND BENDING MACHINE



3. CONCLUSIONS

Now we know that Pneumatic cutting and bending machine is very cheap as compared to hydraulic cutting and bending machine. The range of the cutting and bending thickness can be increased by arranging a high pressure compressor and installing more hardened blades. This machine is advantageous to small sheet metal cutting and bending industries as they cannot afford the expensive hydraulic cutting and bending machine.

REFERENCES

Books Author

1. Handbook of pneumatic system.
Mr. S.R. Mujumdar
2. Handbook of component of pneumatic control system.

Mr. Lev Abramovich Zalmanzon

3. Handbook of guidelines for the use of pneumatic system.

Mr. H.Adelman

4. A.S. Aditya Polapragada & K. Sri Varsha ,“Pneumatic Auto Feed Punching , cutting and Riveting Machine “, International Journal of Engineering Research & Technology (IJERT) Vol. 1 Issue 7, September - 2012 ISSN: 2278-0181.

5. P.M.Pradhan, “Experimental Investigation and Fabrication of Pneumatic Cutting tool”, International Journal of Innovative Research in Science, Engineering and Technology, Vol. 2, Issue 6, June 2013.

6. Pneumatic Systems (principles and maintenance) written by S.R. Majumdar.

7. E. Paul. Degarmo, “Shearing in Metal Cutting”, Pages 518-528, Materials and Processes in Manufacturing, Eighth edition, 2003, Prentice Hall of India Pvt Ltd.

8. K. Mahadevan, Design Data Handbook, Third edition, Reprint 2002, CBS Publishers & distributors.

BIOGRAPHIES



Mr. Dinesh J. Lamse
Student Of Bachelor of engineering, Department of Mechanical Engineering, Abha Gaikwad-Patil College Of Engineering, Nagpur



Mr. Akash E. Navghare
Student Of Bachelor of engineering, Department of Mechanical Engineering, Abha Gaikwad-Patil College Of Engineering, Nagpur



Mr. Rahul I. Chavhan
Student Of Bachelor of engineering,
Department of Mechanical
Engineering, Abha Gaikwad-Patil
College Of Engineering, Nagpur



Prof. Ajay Mahawadiwar
Head Of Department, Mechanical
Engineering, Abha Gaikwad-Patil
College Of Engineering, Nagpur